

# P U S H   A R O U N D



*The Lifting Professionals*

Bolingbrook, IL  
(630) 972-9199

South Holland, IL  
(219) 972-9199

[Click Here to Request a Quote](#)

## Quick up

15/20/24/29/33/35/40



- 39ft 1 in platform height (Quick Up 40)
- 6ft 6 in stowed height (from Quick Up 15 to 33)
- 351 lb Platform capacity (from Quick Up 15 to 29)



**Haulotte**   
GROUP

# Quick up

15/20/24/29/33/35/40

Push around

## The Haulotte® advantages

- Easy to install and set up
- Easy "stand up" access through flip up top rail into basket
- Only one man for loading and unloading
- The Quick Up compact dimensions allows access through standard doorways
- The Quick Up low weight allows works on fragile grounds
- Cage and mast in aluminium

## STANDARD FEATURES

- Push button controls
- 220V A/C power to platform
- AC or DC power available
- Emergency stop button
- Outriggers indicator lights
- Manual emergency valve

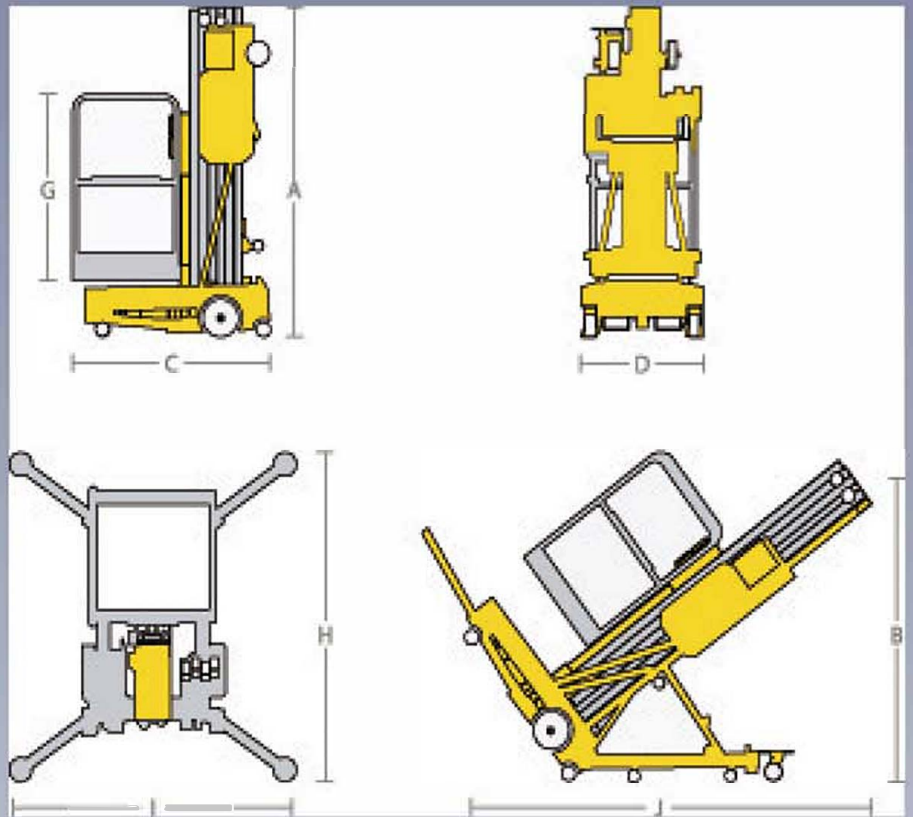

## SPECIFICATIONS

	Quick Up 15	Quick Up 20	Quick Up 24	Quick Up 29	Quick Up 33	Quick Up 35	Quick Up 40
Working Height	20 ft 9 in	25 ft 4 in	29 ft 11 in	34 ft 7 in	38 ft 10 in	41 ft 5 in	45 ft 1 in
Platform height	14 ft 9 in	19 ft 4 in	23 ft 11 in	28 ft 7 in	32 ft 10 in	35 ft 5 in	39 ft 1 in
Platform capacity	351 lb				300 lb		
Max Platform size	2 ft 2 in x 2 ft 3 in						
A - Stowed height	6 ft 6 in					9 ft 1 in	
C - Stowed length	4 ft 0 in	4 ft 2 in	4 ft 5 in	4 ft 7 in	4 ft 9 in	4 ft 5 in	4 ft 7 in
D - Stowed width	2 ft 5 in					2 ft 7 in	
G - Guardrails height	3 ft 9 in						
I x H - Outriggers footprint	4 ft 7 in x 5 ft 7 in			5 ft 3 in x 6 ft 3 in	5 ft 11 in x 6 ft 11 in		6 ft 8 in x 7 ft 7 in
J x B - Tilt bar	6 ft 11 in x 5 ft 9 in					9 ft 3 in x 6 ft 6 in	
AC version	Energy	110 V					
	Weight	719 lb	763 lb	807 lb	884 lb	970 lb	1,017 lb
Batteries version	Energy	12 V					
	Weight	807 lb	851 lb	895 lb	975 lb	1,058 lb	1,105 lb

ANSI/SIA A92.3 and CSA/B354-1 Standards Compliance