

# MRT 2150 / 2550

PRIVILEGE PLUS SERIES 2 ROTATING TELESCOPIC HANDLERS

**PRELIMINARY**



 **MANITOU**  
HANDLING YOUR WORLD

# KEY PERFORMANCE FEATURES

■ POWER ■ PRECISION and ■ ERGONOMICS

**E-RECO**  
RECOGNITION CONTROL



## ■ MAXIMUM LIFT HEIGHT

MRT 2150  
PRIVILEGE+ SERIES 2 **68' 7" [20.9m]**

MRT 2550  
PRIVILEGE+ SERIES 2 **81' 0" [24.7m]**

## ■ MAXIMUM LIFT CAPACITY

**11,000 lbs.**

**[5000 kg]**

## ■ THREE WORK MODES, 3-IN-1 CAPABILITY

The MRT Rotating Telescopic Handlers have the ability to operate in three working modes; telehandler, winch, and platform, performing several tasks with one machine. This capability along with a variety of attachments provide more versatility to adapt for multiple applications.

## ■ HYDROSTATIC TRANSMISSION

Coupled with a two speed gearbox, this system provides optimum power and control of travel for precise placement of the machine.

## ■ UNIQUE LOAD MONITORING SYSTEM AND E-RECO ATTACHMENT RECOGNITION

Advanced software allows for precise material handling, continuously analyzing the position of the load in accordance with the working configuration of the MRT.

The E-RECO attachment recognition system will also detect when an attachment has been properly installed, automatically applying the appropriate load chart and safe operation zones.

## ■ 156 HP (115 kW)



A Tier IV-certified Mercedes-Benz engine provides 498 ft. lbs. (675 Nm) of torque at 1500 rpm.

## ■ ADJUSTABLE STABILIZATION

Telescopic scissor design on the stabilizers enables the legs to be partially deployed when obstacles are present or space is limited.

## ■ EXTRA LARGE BEARING SURFACES ON THE PADS

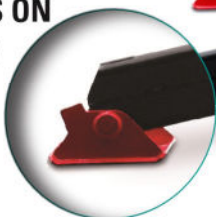

**360°** ROTATION  
ON ALL MODELS

✓ **Ideal for Urban/Metro Construction, Bridge Construction, Rental, Large Contractors, Municipalities, Oil & Gas, Mining and More.**





**DUAL JOYSTICK CONTROLS**

Operate with two electro-hydraulic joysticks that control boom extension, rotation, attachments, load lifting, fork tilting, and directional drive (FNR).

**CABIN COMFORT IS STANDARD**

The enclosed cabin includes; heat, defrost, A/C, an electric window, operator mirrors, full light package, and more. The armrests, steering wheel and cloth suspension seat are all adjustable. An intuitive dashboard with a 7" display shows machine functions, load position, E-RECO attachment recognition, and machine diagnostics.

**SIMPLIFIED ENGINE ACCESS**

The engine is positioned to the side of the chassis allowing easy access from three sides. The air filter and battery are accessible through a hood at the rear of the chassis.

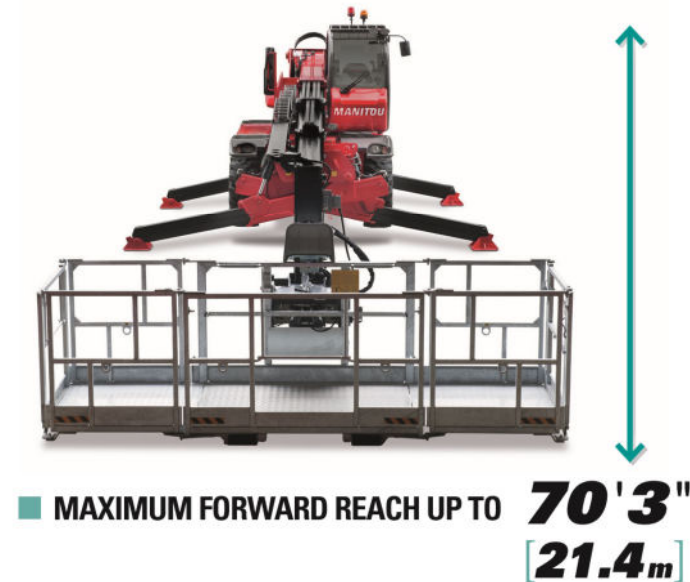

**MAXIMUM FORWARD REACH UP TO 70'3" [21.4m]**

**FRAME LEVELING SYSTEM**

Tackle rough or sloping terrain with ease. Simply push a lever to keep the load horizontal.

**MRT 2150 / 2550 PRIVILEGE PLUS SERIES 2 ROTATING TELESCOPIC HANDLER LOAD CHARTS**

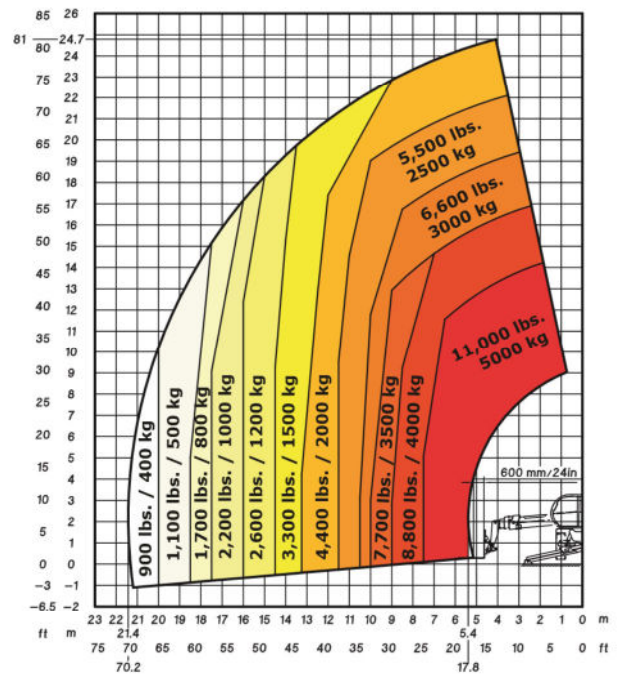
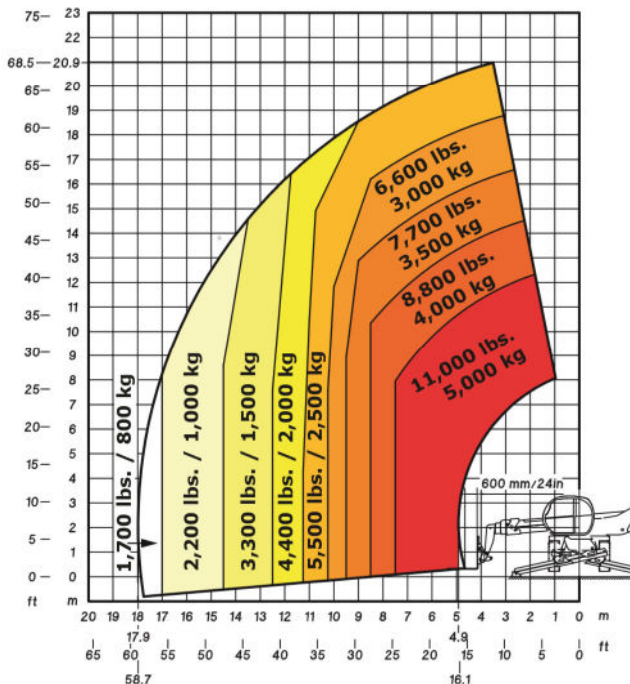







**MRT 2150 Frontal Position, Stabilizers with Forks**

**MRT 2550 Frontal Position, Stabilizers with Forks**

# MRT 2150 /2550 Privilege Plus Series 2 ROTATING TELESCOPIC HANDLER SPECIFICATIONS

# PRELIMINARY DIMENSION REFERENCE DIAGRAMS

	MRT 2150 Privilege Plus Series 2	MRT 2550 Privilege Plus Series 2	
 CAPACITIES	Lift Capacity with Forks (kg)	11,000 lbs. (5000)	
	Lift Capacity with Winch (kg)	11,000 lbs. (5000)	
	Max. Lift Height (m)	68'7" (20.9)	
	Capacity at Max. Lift Height (kg)	5,500 lbs. (2500)	
	Max. Forward Reach (m)	58'9" (17.9)	
	Cap. at Max. Forward Reach (kg)	1,700 lbs. (800)	
 ENGINE	Manufacturer	Mercedes-Benz	
	Power (kW)	156 hp (115) Tier IV	
	Aspiration	Diesel Turbocharged	
	Model	OM 934 E4-5	
	Rated Speed	2200 rpm	
	Torque (Nm) @ rpm	498 ft.-lbs. (675) @ 1200 to 1500	
 COMPONENTS	Transmission	Hydrostatic Transmission	
	Max Travel Speed (km/hr)	25 mph (40)	
	Selective Steering	2-Wheel, 4-Wheel, Crab	
	Service Brake	Hydraulic Multi-Disc Brakes and Front and Rear Axles	
	Parking Brake	Hydraulic Front Axle	
	Axle Manufacturer	Dana	
 HYDRAULIC SYSTEM	Pump Type	Gear	
	Total Capacity (L/min)	30.4 gpm (115)	
	System Pressure (bar)	3989 psi (275)	
 GENERAL SPECIFICATIONS	Approximate Weight (kg)	39,529 lbs. (17930)	
	Length - Less Forks (m)	22'6" (6.87)	
	Width (m)	8'2" (2.49)	
	Ground Clearance (mm)	13.8" (350)	
	Wheelbase (m)	10'0" (3.05)	
	Turning Radius -Outside Tire (m)	16'0" (4.88)	
	Overall Height (m)	10'0" (3.05)	
	Standard Tires	18 x 22.5 16PR	
	Drawbar Pull (daN)	18,434 lbf. (8200)	
	Lateral Frame Leveling	+/- 8°	
	Longitudinal Frame Leveling	N/A	
	 FLUID CAPACITIES	Cooling System (L)	4.75 gal. (18)
		Engine Oil (L)	4 gal. (15)
Hydraulic Oil (L)		59 gal. (225)	
Fuel Tank (L)		80.6 gal. (305)	
Urea- DEF (L)		15 gal. (57)	

(mm)	MRT 2150 Privilege+ Series 2	MRT 2550 Privilege+ Series 2
C	22'6" (6870)	25'9" (7840)
D	17'6" (5350)	17'6" (5350)
E	3'9" (1150)	3'9" (1150)
F	10'0" (3050)	10'0" (3050)
G	3'9" (1150)	3'9" (1150)
H	13.8" (350)	13.8" (350)
J	10'0" (3050)	10'0" (3050)
M	8'2" (2490)	8'2" (2490)
O	18'3" (5555)	18'3" (5555)
T	16" (4880)	16" (4880)
V	3'1.4" (950)	3'1.4" (950)
Y	12°	12°
Z	105°	105°

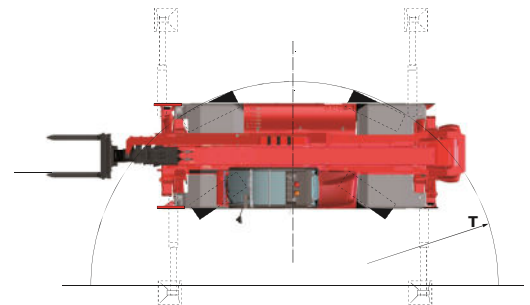
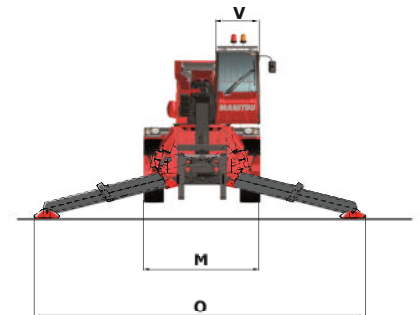
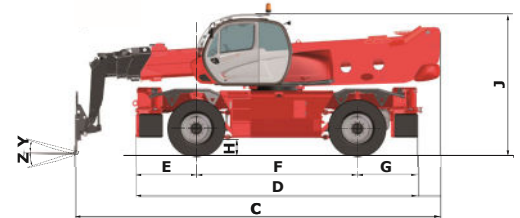

This publication in no way constitutes an offer and the company reserves the right to alter specifications without notice.