

# Technical Data

## Specifications & Capacities

# 228

HYLALAB

**HSL Crawler Crane**  
130 Ton (117.9 metric ton)

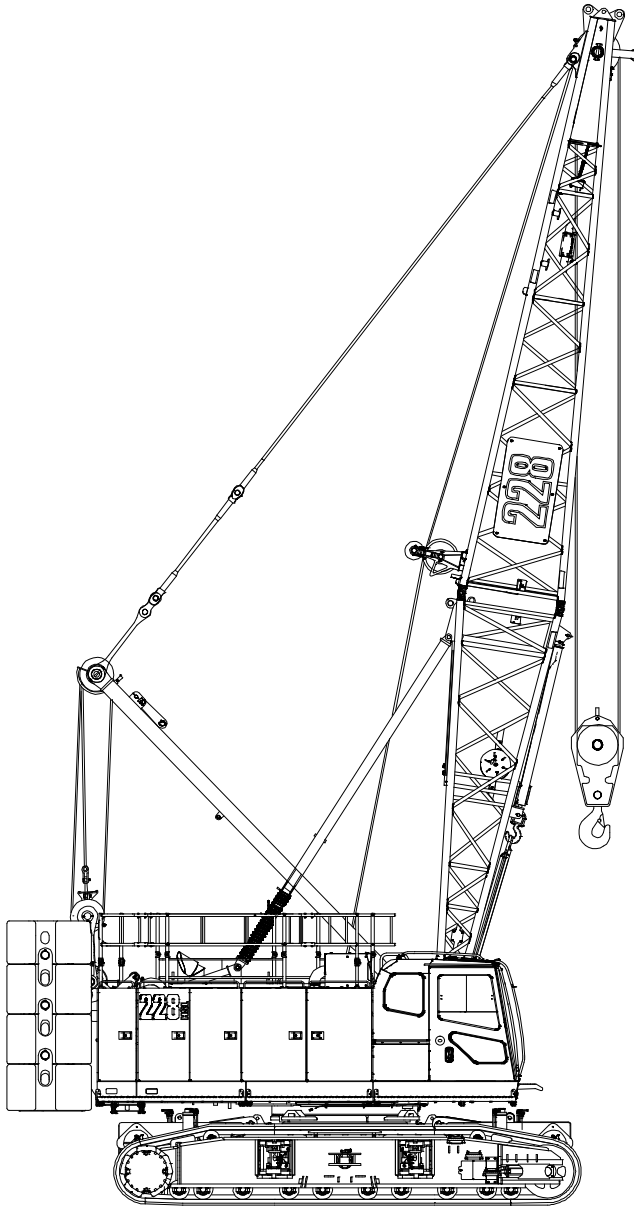

CAUTION: This material is supplied for reference use only. Operator must refer to in-cab Crane Rating Manual and Operator's Manual to determine allowable crane lifting capacities and assembly and operating procedures.



# Table Of Contents

<b>Upper Structure</b> .....	<b>1</b>
Frame .....	1
Engine .....	1
Hydraulic System .....	1
Load Hoist Drums .....	1
Optional Front–Mounted Third Hoist Drum .....	1
Optional Rear–Mounted Fourth Hoist Drum .....	2
Boom Hoist Drum .....	2
Swing System .....	2
Counterweight .....	2
Operator Cab .....	2
Rated Capacity Limiter System .....	2
Boom Hoist System .....	2
Machinery Cab .....	2
Catwalks .....	2
<b>Lower Structure</b> .....	<b>3</b>
Carbody .....	3
Side Frames .....	3
Travel and Steering .....	3
Jack System .....	3
<b>Attachment and Options</b> .....	<b>3</b>
Conventional Tube Boom .....	3
Angle Boom .....	4
Tube Jib .....	4
Auxiliary Tip Extension .....	4
<b>Dimensions</b> .....	<b>5</b>
Base Crane .....	7
Side Frames .....	7
Upper Counterweights .....	8
Lower Counterweights .....	8
Boom .....	9
Fixed Jib .....	11
Hook Balls .....	12
Hook Blocks .....	12
<b>Working Weights</b> .....	<b>13</b>
<b>Transport Weights w/ Side Frames</b> .....	<b>14</b>
<b>Transport Weights w/o Side Frames</b> .....	<b>15</b>
<b>Transport Drawings – Tube Boom</b> .....	<b>16</b>
<b>Load Hoist Performance</b> .....	<b>17</b>
<b>Working Areas</b> .....	<b>18</b>
<b>Attachments</b> .....	<b>19</b>
<b>Main Boom Make–up</b> .....	<b>21</b>
<b>Main Boom Working Range Diagram</b> .....	<b>23</b>
<b>Main Boom Load Chart</b> .....	<b>24</b>

<b>Jib Attachment Make-up .....</b>	<b>26</b>
<b>Jib Attachment Working Range Diagram .....</b>	<b>27</b>
<b>Jib Attachment Load Charts .....</b>	<b>28</b>

# Upper Structure

## Frame

All welded steel frame with precision machined surfaces for mating parts.

### Turntable Bearing

- Inner race with internal swing gear is bolted to lower frame.
- Outer race is bolted to upper frame.

## Engine

### Engine

Full pressure lubrication, oil filter, air cleaner, hour meter, throttle, and electric control shutdown.

### Cummins QSB6.7 Tier 4 Final

Number of cylinders	6
Bore and stroke	4.20 in x 4.88 in (107 x 124mm)
Piston displacement	408 in <sup>3</sup> (6.8L)
Engine rpm at full load speed	2,000 rpm
Hi-idle rpm	2,000 rpm
Gross engine hp	270 hp (210kw)
Peak torque	730 ft lb (990joule) @ 1,500 rpm
Electrical system	24 volt
Fuel tank capacity	122 gal (460L)
Batteries	2—12 volt
Approximate fuel consumption	gal/hr (L/hr)
100% hp	12.62 (47.77)
75% hp	10.57 (40.01)
50% hp	7.57 (28.66)
25% hp	4.16 (15.75)

### Fuel Tank

Equipped with fuel sight level gauges, flame arrester, and self-closing cap with door lock.

## Hydraulic System

### Hydraulic Pumps

The pump arrangement is designed to provide hydraulically powered functions allowing positive, precise control with independent or simultaneous operation of all crane functions.

- Two variable displacement pumps operating at 4,554 psi (320kg/cm<sup>2</sup>) and 74 gal/min (280L/min) powers travel, high speed on the front, rear drums and optional third and fourth drums.
- One variable piston pump operating at 4,482 psi (321kg/cm<sup>2</sup>) and 42.2 gal/min (160L/min) powers the swing motor, jacks, side frame extend and retract, counterweight removal and self-assembly cylinders.
- Two fixed displacement gear type pumps operating at 1,421 psi (100kg/cm<sup>2</sup>) and 10.8 gal/min (41L/min) powers the front and rear drums.
- One fixed displacement gear type pump operating at 1,421 psi (100kg/cm<sup>2</sup>) and 10.8 gal/min (41L/min) controls pilot pressure.

### Hydraulic Reservoir

85 gal (320L), equipped with sight level gauge. Diffusers built in for deaeration.

### Filtration

Ten micron, full flow, line filter in the control circuit. All oil is filtered prior to entering the reservoir.

### Counterbalance Valves

All hoist motors are equipped with counterbalance valves to provide positive load lowering and prevent accidental load drop if the hydraulic pressure is suddenly lost.

## Load Hoist Drums

Each drum contains an axial piston, variable speed hydraulic motor with individual automatic winch motor brakes. Power flow is directed through a patented, semi-outboard mounted, “wet” style multi-disc brake. The brake is mounted on the “output” side of the planetary, which greatly reduces drag associated with most “wet” style brakes in free-fall mode.

- Power up/down & free-fall operation modes
- Automatic brake mode (spring applied, hydraulically released, wet type brake)
- Drum lagging grooved for wire rope
- Drum pawl controlled automatically
- Electronic drum rotation indicators
- Mounted on anti-friction bearings
- 21.81 in (0.55m) root diameter
- 37.81 in (0.96m) flange diameter
- 25.25 in (0.64m) width

The free-fall operation mode is designed to prevent load lowering even if the free-fall switch is accidentally activated.

The automatic brake mode meets all OSHA requirements for personnel handling.

## Optional Front-Mounted Third Hoist Drum

The hydraulic winch is pinned to the front of the upper frame and is used in conjunction with a fleeting sheave and 3-sheave idler assembly to run the wire rope over the boom top section.

- Power up/down for luffer applications where a second load line is needed
- Controlled free spooling capability for pile driving applications or auxiliary hoist line for luffer applications.
- 12.75 in (0.32m) root diameter
- 22.75 in (0.58m) flange diameter
- 17 in (0.43m) width
- Mounted on anti-friction bearings
- Drum lagging grooved for wire rope

## Optional Rear—Mounted Fourth Hoist Drum

Drum contains an axial piston, variable speed hydraulic motor with individual automatic winch motor brakes. Power flow is directed through a patented, semi—outboard mounted, “wet” style multi—disc brake.

- Power up/down & free—fall operation modes
- Automatic brake mode (spring applied, hydraulically released, wet type brake)
- Drum lagging grooved for wire rope
- Drum pawl controlled automatically
- Electronic drum rotation indicators
- Mounted on anti—friction bearings
- 21.50 in (0.54m) root diameter
- 40.94 in (1.04m) flange diameter
- 24.63 in (0.62m) width
- Pins to rear of upper frame
- Plumbing and valving standard with main unit

The free—fall operation mode is designed to prevent load lowering even if the free—fall switch is accidentally activated.

The automatic brake mode meets all OSHA requirements for personnel handling.

## Boom Hoist Drum

Contains a pilot controlled, bi—directional, axial piston motor and a planetary gear reduction unit to provide positive control under all load conditions.

- Spring applied, hydraulically released, disc type brake controlled automatically
- Drum lagging grooved for wire rope
- Drum pawl controlled automatically
- Mounted on anti—friction bearings
- 18.35 in (0.47m) root diameter
- 30.40 in (0.77m) flange diameter
- 11.16 in (0.28m) width

## Swing System

Pilot controlled bi—directional axial piston motors and planetary gear reduction units to provide positive control under all load conditions.

- Spring applied, hydraulically released, 360° multi—plate brake
- Free swing mode when lever is in neutral position
- Four position positive house lock
- Two—speed swing
- Audio/Visual swing alarm
- Maximum swing speed is 2.5 rpm

## Counterweight

Consists of a nine—piece design that can be easily lowered to the ground using the removal cylinders.

- “A” upper counterweight consists of one, 25,920 lb (11 757kg) base slab
- “B” upper counterweight consists of left, 9,410 lb (4 268kg) and right, 9,440 lb (4 282kg) counterweights
- “C” upper counterweight consists of left, 9,410 lb (4 268kg) and right, 9,440 lb (4 282kg) counterweights
- “D” upper counterweight consists of left, 8,050 lb (3 651kg) and right, 7,980 lb (3 619kg) counterweights
- Two carbody counterweights — 13,250 lb (6 022kg) each

Total combined counterweight, “ABCD” plus carbody counterweights is 106,150 lb (48 149kg).

## Operator Cab

Fully enclosed modular steel compartment is independently mounted and padded to protect against vibration and noise.

- All tinted/tempered safety glass
- Folding hinge entry door and sliding front glass window
- 19,000 BTU hot water heater
- 18,600 BTU air conditioner
- Door and window locks
- Circulating fan
- Sun visor
- Cloth seat
- Defroster
- Windshield wipers and washer
- Dry chemical fire extinguisher
- Engine instrumentation panel (voltmeter, engine oil pressure, engine water temperature, fuel level, hydraulic oil temperature, hour meter, and service monitor system)
- Electronic drum rotation indicators for front and rear hoist drums
- Rearview camera
- Six way adjustable seat
- Hand and foot throttle
- Fully adjustable single axis controls
- Swing lever with swing brake and horn located on handle
- Bubble type level
- Ergonomic gauge layout
- Controls shut off lever
- Control stand is adjustable for operator comfort.

## Rated Capacity Limiter System

The HSL rated capacity limiter system is a boom hoist load cell system. This system provides the operator with useful geometrical data, to include:

- Main Boom Length
- Main Boom Angle
- Jib Length
- Jib Angle
- Operating Mode
- Load Radius
- Boom Tip Height
- Audible Alarm
- Pre—Warning Light
- Overload Light
- Load On Hook
- Function kick—outs including over load
- Operator settable stops (ramped stops)
- Anti—Two Block Indicator
- Boom hoist dead end load cell

## Boom Hoist System

Designed to lift off maximum boom or maximum boom plus jib unassisted. Operates up to a maximum boom angle of 80° for conventional boom. Boom hoist limit system limits maximum boom angle operation.

- Pin—on bail frame
- 12—part reeving with 20mm (0.787 in) wire rope
- 22 ft (6.71m) live mast
- Two 1.25 in (32mm) pendants
- Tubular boom backstops (telescopic type)
- Sheaves contain sealed anti—friction bearings
- Boom speed from 10°—70° is 69 seconds with no load. Speed was determined using 100 ft (30.48m) of tube boom.

## Machinery Cab

Hinged doors (five on right side, three on left side) for machinery access. Storage/rigging box located on operator’s side of upper house. Equipped with rooftop access ladder and skid resistant finish on roof.

## Catwalks

Standard on right and left sides. Catwalks fold up or can be removed to reduce transport weight.

# Lower Structure

## Carbody

### Lower Frame

All welded high strength steel [65,000 psi (448.16MPa) yield] box construction frame with precision machined surfaces for turntable bearing and rotating joint.

- 9 ft 9.6 in (2.98m) overall width
- 11 ft 6 in (3.50m) overall length

## Side Frames

### Side Frames

All welded, precision machined, steel frames can be hydraulically extended and retracted by a hydraulic cylinder mounted in the lower frame.

- 14 ft 6 in (4.42m) extended gauge
- 8 ft 9.6 in (2.68m) retracted gauge
- 21 ft (6.4m) overall length
- 36 in (0.91m) wide track shoes
- Sealed (oil filled) drive planetaries
- Compact travel drives
- Automatic hydraulic track adjustment system

### Track Rollers

- Ten sealed (oil filled) track rollers per side frame
- Heat treated, mounted on oil filled anti-friction bearings

### Tracks

Heat treated, self-cleaning, multiple hinged track shoes joined by one-piece full floating pins; 53 shoes per side frame

### Take Up Idlers

Cast steel, heat treated, self-cleaning, mounted on aluminum/bronze bushings. Lubricated through idler shaft.

## Travel and Steering

### Travel and Steering

Each side frame contains a pilot controlled, bi-directional, axial piston motor and a planetary gear reduction unit to provide positive control under all load conditions.

- Individual control provides smooth, precise maneuverability including full counter-rotation.
- Spring applied, hydraulically released disc type brake controlled automatically
- Maximum travel speed is 1.3 mph (2.15km/h).
- Designed to 30% gradeability

## Jack System

System contains four hydraulic cylinders individually pinned on swing out beams.

- Individual controls are mounted on carbody.
- Minimum height of carbody when resting on pontoons is 16 in (0.41m).
- Maximum height of carbody when resting on pontoons is 44 in (1.1m).

# Attachment and Options

## Conventional Tube Boom 45–235 ft (13.72–71.65m)

### Basic Boom

45 ft (13.72m) two-piece design that utilizes a 20 ft (6.10m) base section and a 25 ft (7.62m) open throat top section with in-line connecting pins on 65 in (1.65m) wide and 54 in (1.37m) deep centers.

- Boom foot on 55.12 in (1.40m) centers
- 4 in (10.16cm) diameter chords
- Lugs on base section for self assembly
- Deflector roller on top section
- Permanent skid pads mounted on top section to protect head machinery
- Permanent stowable idler sheave pack
- Quick reeve capable top section

- Five, 21.53 in (54.69cm) root diameter polyamide sheaves mounted on sealed anti-friction bearings
- Tip extension and jib connecting lugs on top section
- Mechanical boom angle indicator
- Self assembly cylinder – optional

### Tube Boom Extensions

The following table provides the lengths available and the suggested quantity to obtain maximum boom in 10 ft (3.05m) increments. Midpoint pendant connections are required at 100 ft (30.48m) for boom lengths of 215 ft (65.53m), 225 ft (68.58m), and 235 ft (71.6m).

- Polyamide wear blocks on top of each extension

Tube Boom Extensions		Quantity For Max Boom
ft	m	
10	3.05	1
20	6.10	2
30	9.14	2
40	12.19	2

- Maximum tip height of 238 ft 7 in (72.73m)
- Boom connecting pins storage on each extension

## Angle Boom 45–155 ft (13.72–47.24m)

### Basic Angle Boom

45 ft (13.72m) two-piece design that utilizes a 20 ft (6.10m) base section and a 25 ft (7.62m) top section with in-line connecting pins on 60 in (1.52m) wide and 54 in (1.37m) deep centers.

- Boom foot on 55.12 in (1.40m) centers
- 4 in x 4 in x 0.5 in (10.16cm x 10.16cm x 1.27cm) angle chords
- Lugs on base section for self assembly
- Deflector roller on top section
- Rigid quick reeve sheave guards
- Tip extension and jib connecting lugs on top section
- Three, 24.75 in, (62.87cm) root diameter lift sheaves mounted on sealed anti-friction bearings with rope guards
  - Four sheave for heavy lifting – optional

### Angle Boom Extensions

The following table provides the lengths available and the suggested quantity to obtain maximum boom in 10 ft (3.05m) increments. Midpoint pendant connections are not required.

Angle Boom Extensions		Quantity For Max Boom
ft	m	
10	3.05	1
20	6.10	2
30	9.14	2

- Appropriate length pendants
- Maximum angle boom tip height of 160.51 ft (48.92m).

## Tube Jib 30–75 ft (9.14–22.86m)

### Basic Tube Jib

30 ft (9.14m) two-piece design that utilizes a 15 ft (4.57m) base section and a 15 ft (4.57m) top section with in-line connecting pins on 32 in (0.81m) wide and 24 in (0.61m) deep centers.

- 2 in (50.8mm) diameter chords
- One 18.50 in (0.47m) root diameter steel sheave mounted on sealed anti-friction bearings

- 15 ft (4.57m) jib extensions provide jib lengths of 45 ft (13.72m), 60 ft (18.29m), and 75 ft (22.86m).
- Jib offset angles at 5°, 15°, and 25°
- The maximum tip height of boom + jib [205 ft + 75 ft (62.5 + 22.86m)] is 281.75 ft (85.93m).

## Auxiliary Tip Extension

Designed to use in place of jib to provide clearance between working hoist lines. The extension is equipped with two nylon 18 in (45.72cm) root diameter sheaves mounted on sealed anti-friction bearings. Maximum capacity is 18.5 Ton (16.78mt).



# Dimensions

General Dimensions	English	Metric
Basic Boom	45 ft	13.72m
Minimum Load Radius	12.15 ft	3.70m
Maximum Boom Angle	80°	80°
Track Shoe Width	36 in	0.91m

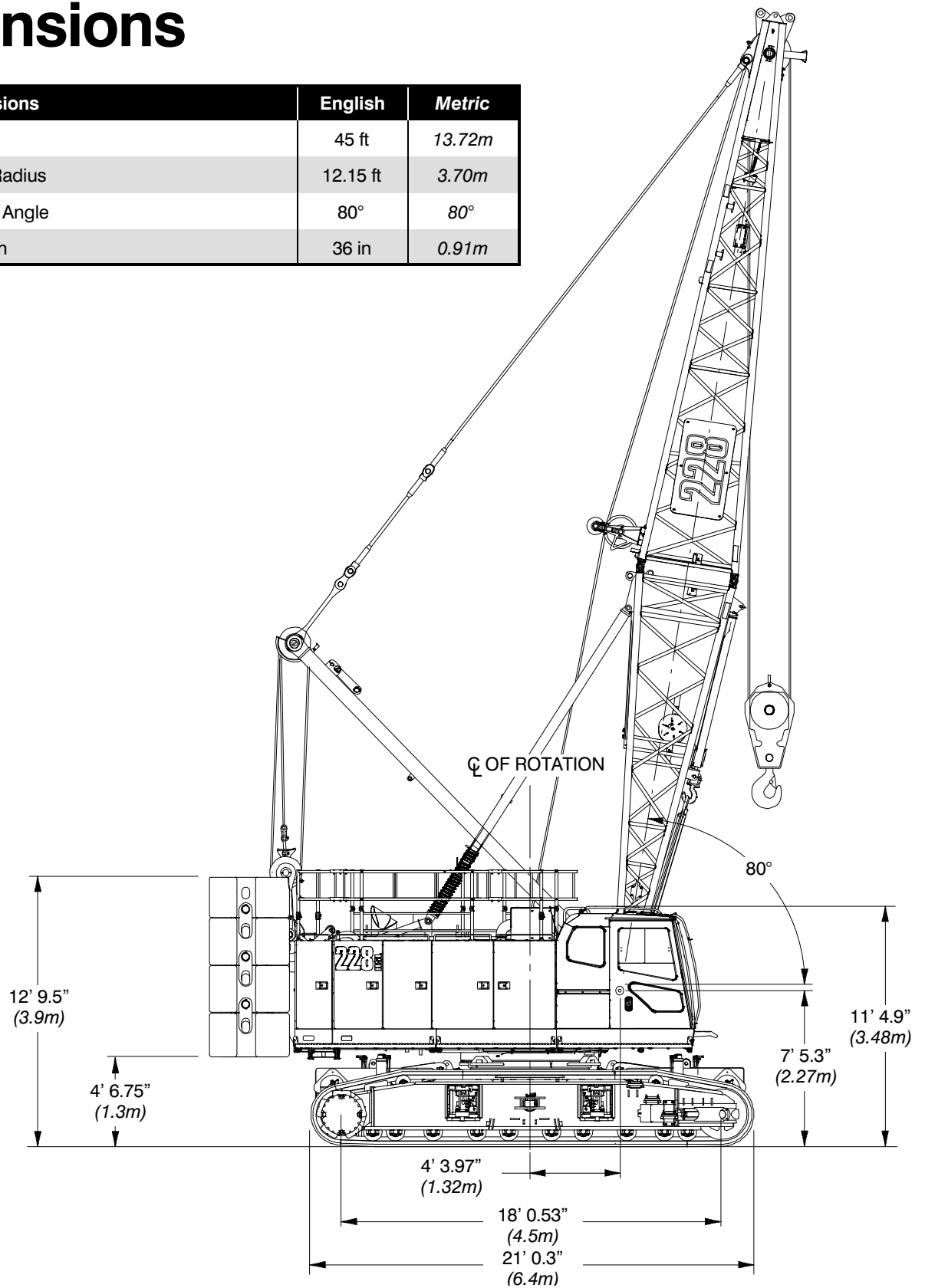

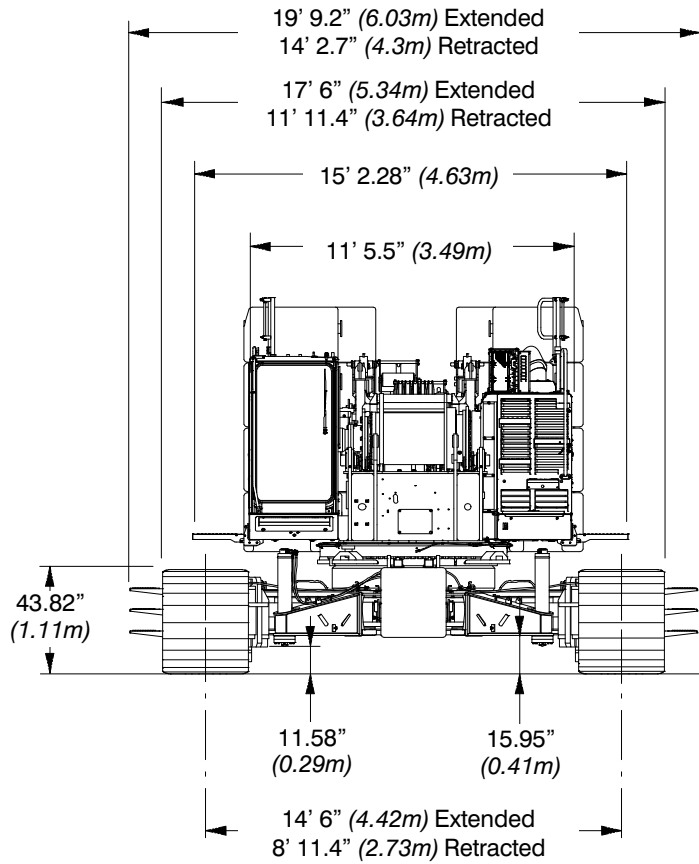
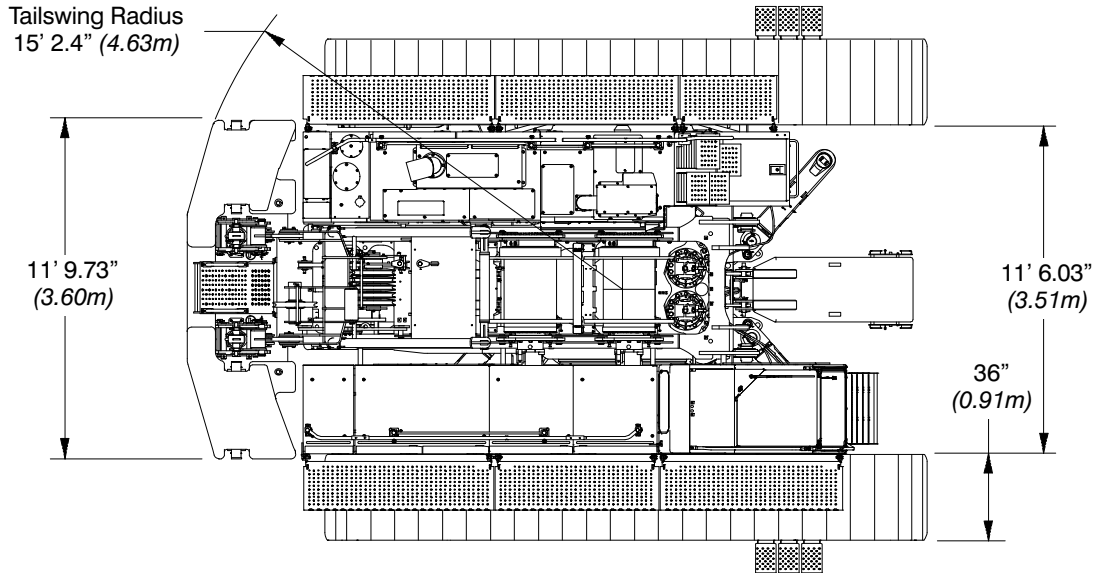

# Base Crane

## Base Crane ①

Length 1	21 ft	(6.41m)
Length 2	41 ft 1.65 in	(12.54m)
Length 3	4 ft 10.25 in	(1.48m)
Height	14 ft 6.6 in	(4.44m)
Weight:		
Tube Boom	119,541 lb	(54 224kg)
Angle Boom	120,245 lb	(54 543kg)

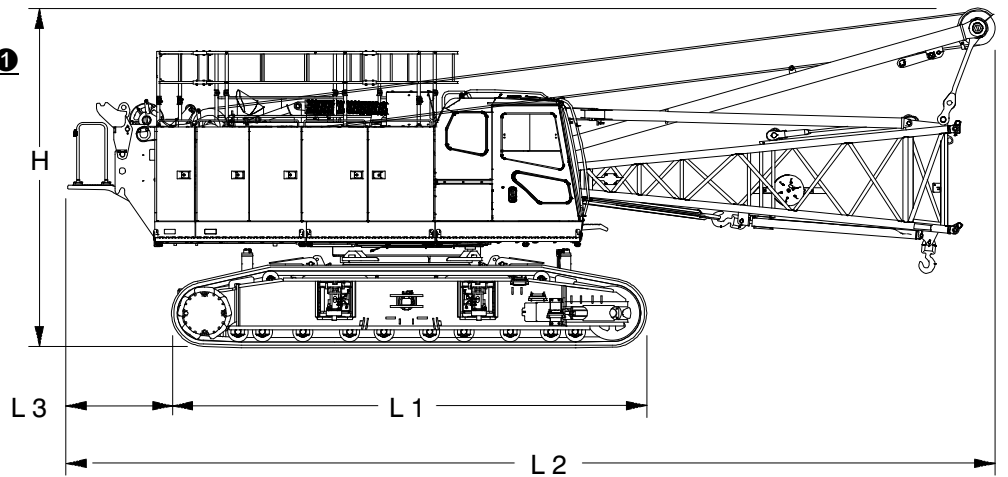

## Base Crane w/ Jacks

Width 1	14 ft 1 in	(4.29m)
Width 2	8 ft 11 in	(2.74m)
Height*	44 in	(1.12m)
Weight:		
Tube Boom	74,225 lb	(33 668kg)
Angle Boom	74,929 lb	(33 988kg)

\* Maximum height on pontoons

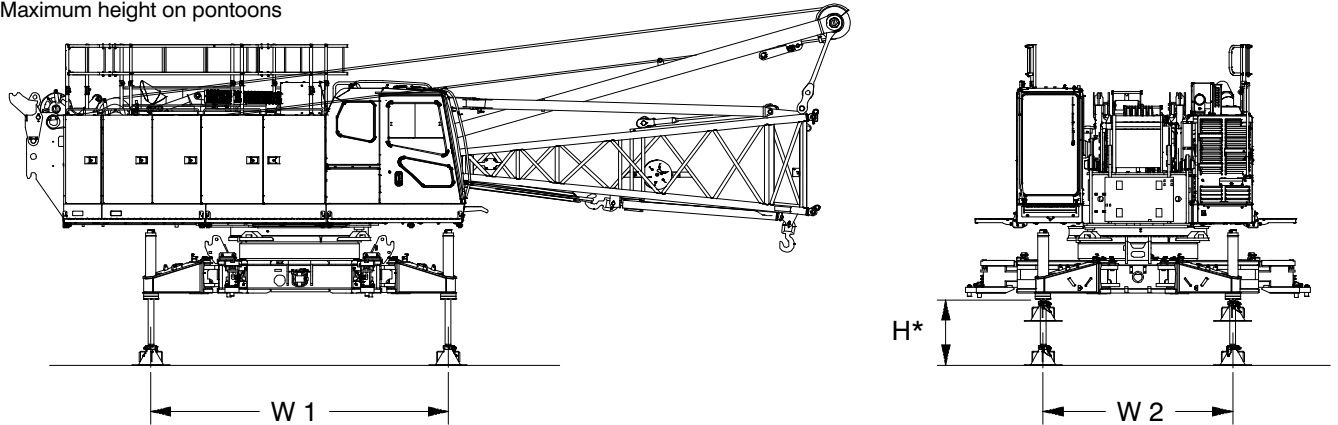

# Side Frames

## Side Frames ②

Length	21 ft	(6.41m)
Width	36 in	(0.91m)
Height	3 ft 7.8" in	(1.11m)
Weight	22,877 lb	(10 377kg)

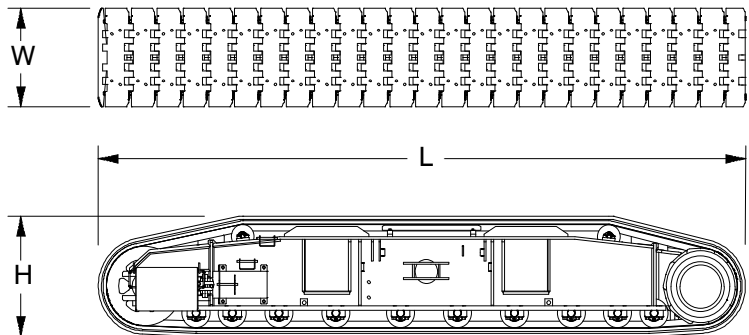

Number inside black circle "①" = # of components

# Upper Counterweights

## “A” Slab Counterweight ①

Length	45.44 in	(1.15m)
Width	11 ft 9.75 in	(3.60m)
Height	6 ft 6 in	(1.98m)
Weight	25,920 lb	(11 757kg)

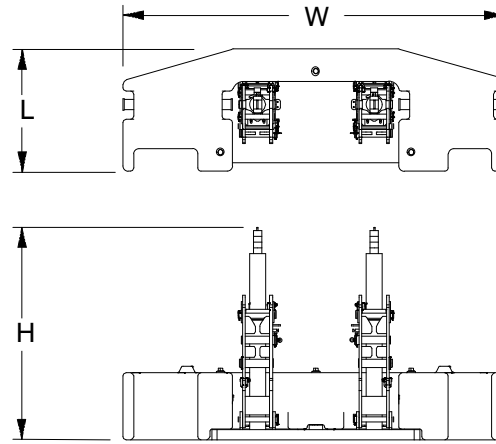

## “B” Wing Counterweights ②

Length 1	55.12 in	(1.40m)
Length 2	53 in	(1.35m)
Width	45.44 in	(1.15m)
Height	29.44 in	(0.75m)
Weight 1	9,410 lb	(4 268kg)
Weight 2	9,440 lb	(4 282kg)

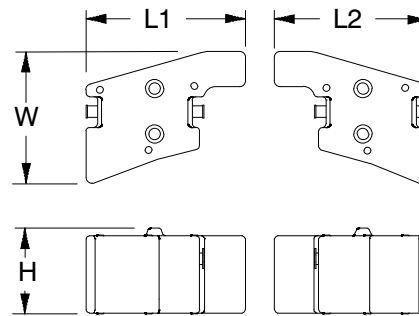

## “C” Wing Counterweights ②

Length 1	55.12 in	(1.40m)
Length 2	53 in	(1.35m)
Width	45.44 in	(1.15m)
Height	29.44 in	(0.75m)
Weight 1	9,410 lb	(4 268kg)
Weight 2	9,440 lb	(4 282kg)

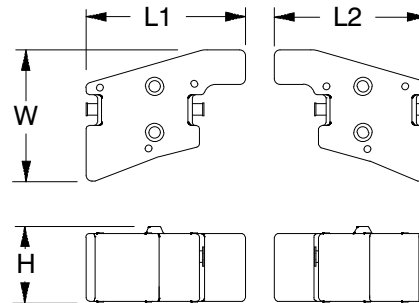

## “D” Wing Counterweights ②

Length 1	55.12 in	(1.40m)
Length 2	53 in	(1.35m)
Width	45.44 in	(1.15m)
Height	23.03 in	(0.58m)
Weight 1	8,050 lb	(3 651kg)
Weight 2	7,980 lb	(3 620kg)

# Lower Counterweights

## Car Body Counterweights ②

Length	6 ft 2 in	(1.89m)
Width	32.44 in	(1.82m)
Height	34.45 in	(0.88m)
Weight	13,250 lb	(6 010kg)

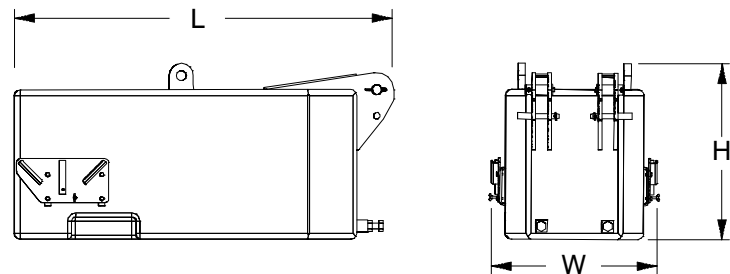

Number inside black circle “①” = # of components

# Boom

**65 in (1.65m) x 54 in (1.37m)**

## Tube Boom Extensions

### 10 ft (3.05m) Extension

Length	10 ft 7.9 in	(3.25m)
Width	70.62 in	(1.79m)
Height	63.81 in	(1.62m)
Weight	1,061 lb	(481kg)

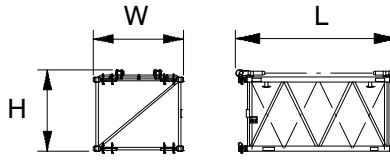

### 20 ft (6.10m) Extension

Length	20 ft 7.9 in	(6.30m)
Width	70.62 in	(1.79m)
Height	63.81 in	(1.62m)
Weight	1,613 lb	(732kg)

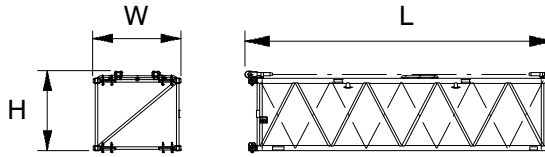

### 30 ft (9.14m) Extension

Length	30 ft 7.9 in	(9.34m)
Width	70.62 in	(1.79m)
Height	63.81 in	(1.62m)
Weight:	2,166 lb	(982kg)

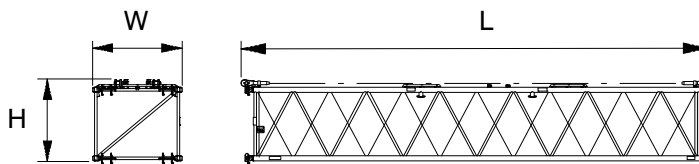

### 40 ft (12.19m) Extension

Length	40 ft 7.9 in	(12.40m)
Width	70.62 in	(1.79m)
Height	63.81 in	(1.62m)
Weight:	2,755 lb	(1 250kg)

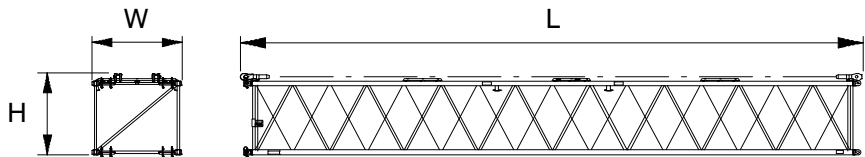

**60 in (1.52m) x 54 in (1.37m)**

## Angle Boom Extensions

### 10 ft (3.05m) Extension

Length	10 ft 4 in	(12.40m)
Width	65.62 in	(1.67m)
Height	58 in	(1.47m)
Weight:	1,292 lb	(586.2kg)

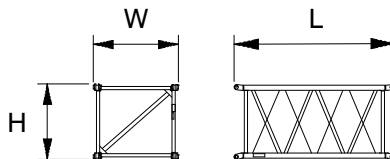

### 20 ft (6.10m) Extension

Length	20 ft 4 in	(12.40m)
Width	65.62 in	(1.67m)
Height	58 in	(1.47m)
Weight:	2,341 lb	(1 062kg)

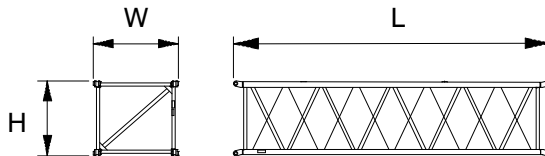

### 30 ft (9.14m) Extension

Length	30 ft 4 in	(12.40m)
Width	65.62 in	(1.67m)
Height	58 in	(1.47m)
Weight:	3,137 lb	(1 423kg)

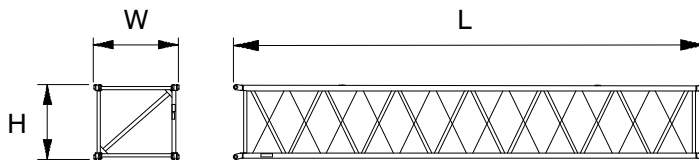

**25 ft (7.62m) Tube Boom  
Top Section** ①

Length	27 ft 6 in	(8.38m)
Width	68.5 in	(1.74m)
Deep	54 in	(1.37m)
Height		
H1 – folded Idler sheave	64.4 in	(1.64m)
H2 – w/ Idler sheave	89.6 in	(2.28m)
Weight	3,588 lb	(1 627kg)

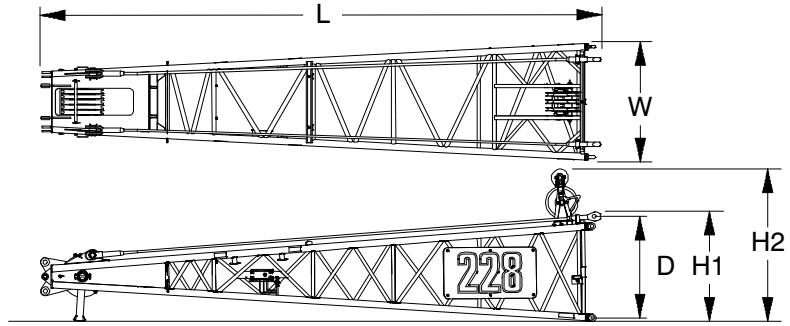

**25 ft (7.62m) Angle Boom  
Top Section** ①

Length	27 ft 8.25 in	(8.44m)
Width	61.87 in	(1.57m)
Deep	54 in	(1.37m)
Height	58 in	(1.47m)
Weight		
w/ 3 sheaves	876.6 lb	(397.7kg)
w/ 4 sheaves	1,071.4 lb	(486.1kg)

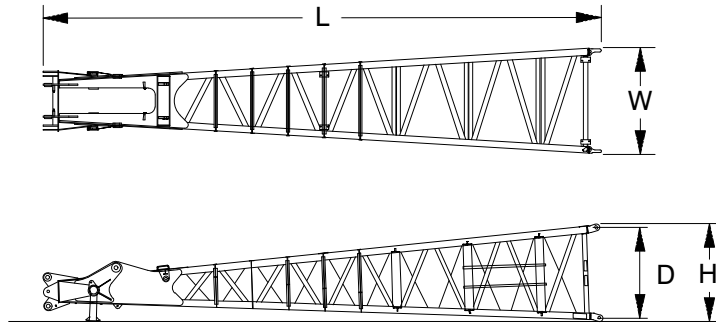

**20 ft (6.10m) Tube Boom  
Base Section** ①

Length	20 ft 7.5 in	(6.29m)
Width	70.60 in	(1.79m)
Deep	54 in	(1.37m)
Height	70.50 in	(1.79m)
Weight		
w/o Self Assembly	2,665 lb	(1 211kg)
w/ Self Assembly	3,039 lb	(1 381kg)

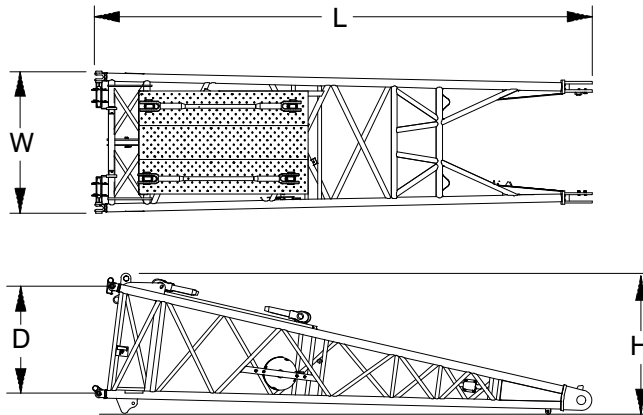

**20 ft (6.10m) Angle Boom  
Base Section** ①

Length	20 ft 7.5 in	(6.29m)
Width	65.50 in	(1.66m)
Deep	54 in	(1.37m)
Height	65 in	(1.65m)
Weight	3,174 lb	(1 440kg)

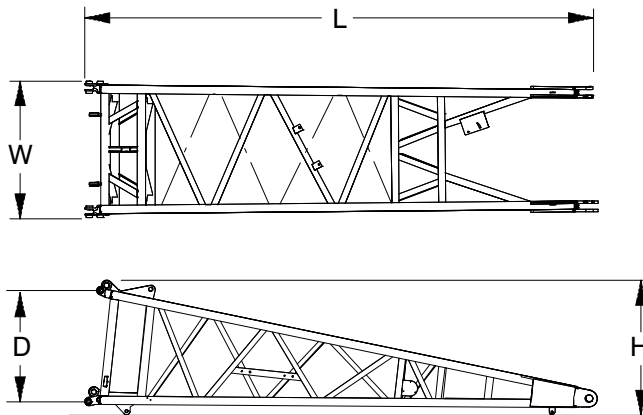

Number inside black circle “①” = # of components  
\* – Optional equipment

### Auxiliary Tip Extension\* ①

Length	70.35 in	(1.79m)
Width	24.50 in	(0.62m)
Height	42.91 in	(1.09m)
Weight	720 lb	(327kg)

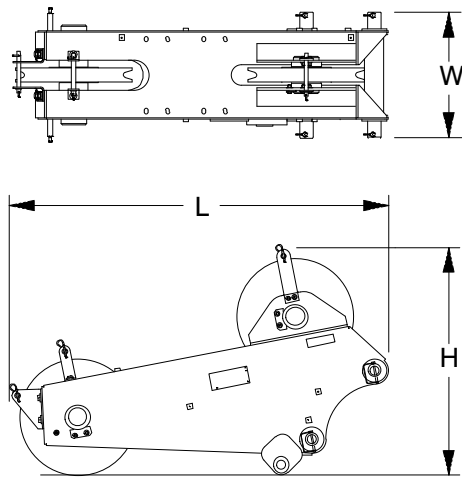

## Fixed Jib

### 15 ft (4.57m) Jib

#### Top Section\* ①

Length	16 ft 1.50 in	(4.91m)
Width	34.50 in	(0.88m)
Height	26.50 in	(0.67m)
Weight†	604 lb	(274kg)

† Weight includes pendants and hardware.

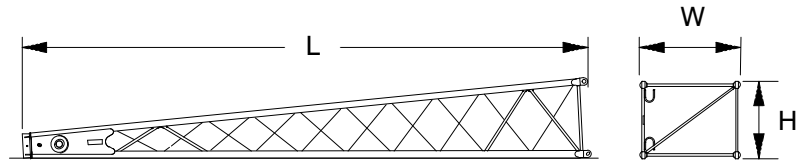

### 15 ft (4.57m) Jib

#### Base Section\* ①

Length	15 ft 3.50 in	(4.66m)
Width	34.50 in	(0.88m)
Height 1	26.50 in	(0.67m)
Height 2	54.50 in	(1.38m)
Weight†	1,106 lb	(502kg)

† Weight includes pins, basic frontstay & backstay pendants, and hardware.

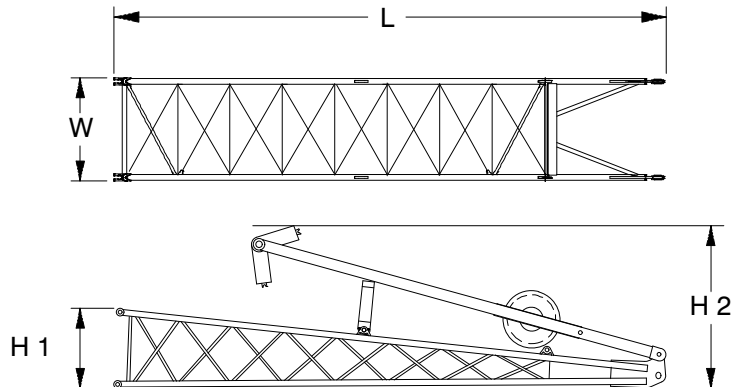

### 15 ft (4.57m) Jib Extension\* ①

Length	15 ft 2.50 in	(4.64m)
Width	34.50 in	(0.88m)
Height	26.50 in	(0.67m)
Weight†	330 lb	(150kg)

† Weights includes pins, pendants, and hardware.

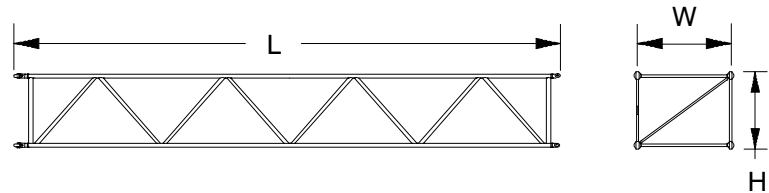

Number inside black circle “①” = # of components

\* – Optional equipment

# Hook Balls

## 15 Ton (13.6mt) Swivel

### Hook Ball\* 1

Width	17.50 in	(0.44m)
Height	40.50 in	(1.03m)
Weight	767 lb	(348kg)

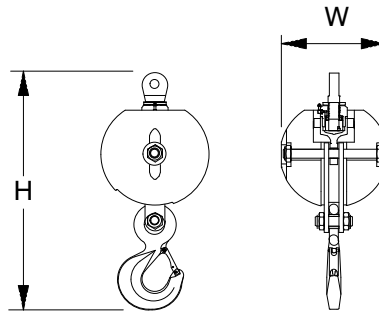

## 15 Ton (13.6mt) Non-Swivel

### Hook Ball\* 1

Width	18 in	(0.46m)
Height	39.50 in	(1.00m)
Weight	748 lb	(339kg)

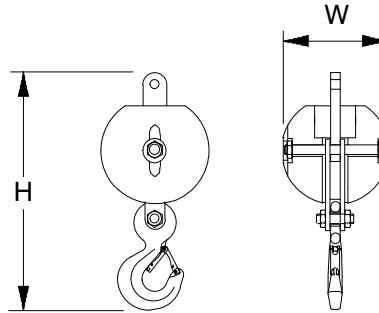

# Hook Blocks

## 30 Ton (22.7mt)

### 1–Sheave Quick Reeve

### Hook Block\* 1

Width1	13.38 in	(0.34m)
Width2	27.44 in	(0.71m)
Width3	10.03 in	(0.25m)
Height	63.06 in	(1.60m)
Weight	1,700 lb	(771kg)

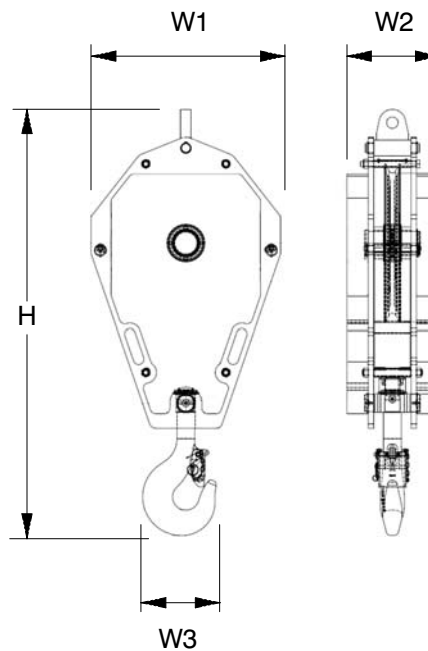

Number inside black circle “**1**” = # of components

\* – Optional equipment



**90 Ton (81.8mt)  
3–Sheave Quick Reeve Hook  
Block\* ①**

Width1	15.81 in	(0.40m)
Width2	27.94 in	(0.71m)
Width3	15.75 in	(0.4m)
Height	75.88 in	(1.93m)
Weight	2,400 lb	(1 091kg)

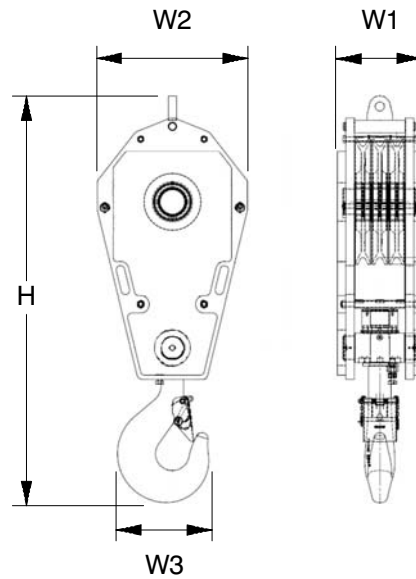

**130 Ton (118.2mt)  
5–Sheave Quick Reeve Hook  
Block\* ①**

Width1	22.50 in	(0.57m)
Width2	27.94 in	(0.71m)
Width3	18.26 in	(0.46m)
Height	76.56 in	(1.95m)
Weight	3,300 lb	(1 500kg)

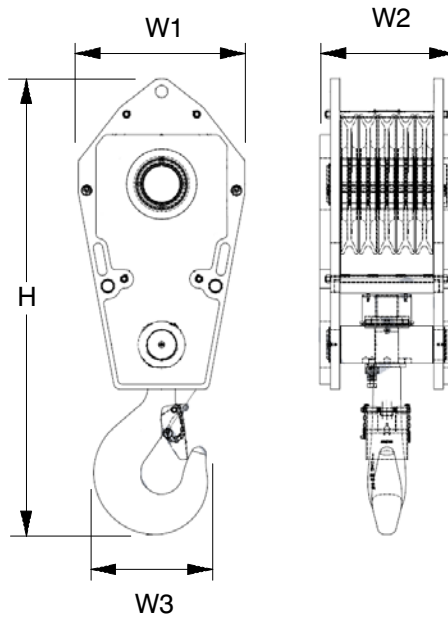

Number inside black circle “①” = # of components  
\* – Optional equipment

# Working Weights

Based on basic crane including Cummins QSB6.7 T4f diesel engine, turntable bearing, live mast, 12 part boom hoist reeving, backstops, jacks, crawler lower with 36 in (0.91m) wide track shoes, sealed track rollers, and catwalks, plus the following:		Ctwt “A”	Ctwt “AB”	Ctwt “ABCD” + “A” Lower Ctwt
		lb (kg)	lb (kg)	lb (kg)
Lifting crane – includes 45 ft (13.72m) basic tube, self assembly cylinder, 820 ft (249.94m) of 26mm type “ZB” hoist rope, 650 ft (198.12m) of 26mm type “ZB” hoist rope, 130 Ton (118.2mt) 5–sheave hook block, and basic pendants.		154,937 (70 279)	173,677 (78 780)	235,041 (106 614)
Ground Bearing Pressure	psi	8.10	9.27	11.80
	kg/cm <sup>2</sup>	0.57	0.65	0.83

# Transport Weights w/ Side Frames

Base Crane: 20' Tube Base Section, Rigid Boom Backstops, 110 gal (416L) of Fuel. Catwalks (Front and Right Side), Side Frames, 22' (6.7m) Live Mast, Bridle & Spreader Bar, 12-part Boom Hoist Reeving, 820' (249.94m) Of Type "ZB" Front Hoist Rope, 650' (198.12m) Of Type "ZB" Rear Hoist Rope.

Item Description	Gross Weight		Transport Loads				
	lb	kg	#1	#2	#3	#4	#5
Base Crane	119,541	54 224	1				
Base Counterweight w/ Cylinders	25,900	11 748		1			
Add Upper Counterweight Wing (Right)	9,440	4 282			1	1	
Add Upper Counterweight Wing (Left)	9,410	4 268				2	
Add T4 Upper Counterweight Wing (Right)	7,980	3 620		1			
Add T4 Upper Counterweight Wing (Left)	8,050	3 651					1
Add Lower Frame Counterweight	13,300	6 033					2
Add Lower Jacking System	2,700	1 225					
Add Hydraulic Third Drum without Rope	1,850	839					
Add Hydraulic Fourth Drum without Rope	4,367	1 981					
Add 25' (7.62m) Tube Top Section	3,496	1 586			1		
Add 10 ft (3.05m) Tube Extension w/Pins and Pendants	969	440		1			
Add 20 ft (6.10m) Tube Extension w/Pins and Pendants	1,569	712				1	1
Add 30 ft (9.14m) Tube Extension w/Pins and Pendants	2,171	985			1		1
Add 40 ft (12.19m) Tube Extension w/Pins and Pendants	2,760	1 252		1		1	
Add 20' (6.1m) Angle Base Section w/ Backstops	4,700	2 132					
Add 25' (7.62m) Angle Top Section (3 Sheaves)	4,994	2 265					
Add 25' (7.62m) Angle Top Section (4 Sheaves)	5,180	2 350					
Add 10 ft (3.05m) Angle Extension w/Pins and Pendants	1,581	717					
Add 20 ft (6.10m) Angle Extension w/Pins and Pendants	2,700	1 225					
Add 30 ft (9.14m) Angle Extension w/Pins and Pendants	3,566	1 618					
Add Quick Draw Assembly	340	154	1				
Add 30' (9.1m) Tube Jib	1,640	744		1			
Add 15' (4.6m) Tube Jib Extension	270	122					3
Add 5' (1.5m) Auxiliary Tip Extension w/ Nylon Sheave	720	327					
Add 5' (1.5m) Auxiliary Tip Extension w/ Steel Sheave	1,000	454					
Add Pile Driver Lead Adaptor	198	90					
Add Hoist Rope - 26mm x 820' Type "YB"	1,870	848					
Add Jib Wire Rope - 26mm x 650' Type "YB"	1,482	672					
Add 3rd Drum Wire Rope - 0.75" x 550' type "DB"	572	259					
Add 4th Drum Wire Rope - 26mm x 620' type "RB"	1,147	520					
Add 15 Ton (13.6mt) Hook Ball (Non---swivel)	750	340					
Add 15 Ton (13.6mt) Hook Ball (Swivel)	767	348			1		
Add 30 Ton (27.3mt) 1 Sheave Quick Reeve Hook Block	1,700	771					
Add 90 Ton (81.8mt) 3 Sheave Quick Reeve Hook Block	2,400	1 089					
Add 130-ton (100mt) 4 Sheave Hook Block	3,300	1 497				1	
Remove Live Mast	-2,082	-944					
Remove 20' (6.1m) Tube Base Section w/ Backstops	-3,996	-1 813					
Remove Hoist Rope - 26mm x 820' Type "ZB"	-1,747	-792					
Remove Boom Hoist Rope - 20mm x 470' Type "DB"	-541	-245					
Remove Jib Wire Rope - 26mm x 650' Type "ZB"	-1,385	-628					
Remove 110 gal (416L) of Fuel	-797	-362					
Remove Side Frames	-45,316	-20 555					
Approximate Total Shipping Weight	lb		119,881	39,249	15,874	35,889	39,200
	kg		54,378	17,803	7,200	16,297	17,781

Notes:  
 Estimated weights vary by  $\pm$  2%. Numbers in the load columns (numbers 1–5) represent quantities.  
 Estimated transport loads assume the load out consist of 230' (70.1m) of tube boom and 75' (22.86m) of jib with full counterweight.  
 Support loads were targeted at 45,000 lb (20 412kg), 8' 6" (2.6m) wide, 48' (14.6m) long, and 13' 6" (4.1m) high using a drop deck trailer. This may vary depending on state laws, empty truck/trailer weights, and style of trailer.

# Transport Weights w/o Side Frames

Base Crane: 20' Tube Base Section, Rigid Boom Backstops, 110 gal (416L) of Fuel. Catwalks (Front and Right Side), 22' (6.7m) Live Mast, Bridle & Spreader Bar, 12–part Boom Hoist Reeving, 820' (249.94m) Of Type "ZB" Front Hoist Rope, 650' (198.12m) Of Type "ZB" Rear Hoist Rope.

Item Description	Gross Weight		Transport Loads					
	lb	kg	#1	#2	#3	#4	#5	#6
Base Crane	74,225	33 668	1					
Base Counterweight w/ Cylinders	25,900	11 748		1				
Add Upper Counterweight Wing (Right)	9,440	4 282			1	1		
Add Upper Counterweight Wing (Left)	9,410	4 268				2		
Add T4 Upper Counterweight Wing (Right)	7,980	3 620		1				
Add T4 Upper Counterweight Wing (Left)	8,050	3 651					1	
Add Lower Frame Counterweight	13,300	6 033					2	
Add Lower Jacking System	2,700	1 225						
Add Hydraulic Third Drum without Rope	1,850	839						
Add Hydraulic Fourth Drum without Rope	4,367	1 981						
Add 25' (7.62m) Tube Top Section	3,496	1 586			1			
Add 10 ft (3.05m) Tube Extension w/Pins and Pendants	969	440		1				
Add 20 ft (6.10m) Tube Extension w/Pins and Pendants	1,569	712				1	1	
Add 30 ft (9.14m) Tube Extension w/Pins and Pendants	2,171	985			1		1	
Add 40 ft (12.19m) Tube Extension w/Pins and Pendants	2,760	1 252		1		1		
Add 20' (6.1m) Angle Base Section w/ Backstops	4,700	2 132						
Add 25' (7.62m) Angle Top Section (3 Sheaves)	4,994	2 265						
Add 25' (7.62m) Angle Top Section (4 Sheaves)	5,180	2 350						
Add 10 ft (3.05m) Angle Extension w/Pins and Pendants	1,581	717						
Add 20 ft (6.10m) Angle Extension w/Pins and Pendants	2,700	1 225						
Add 30 ft (9.14m) Angle Extension w/Pins and Pendants	3,566	1 618						
Add Quick Draw Assembly	340	154	1					
Add 30' (9.1m) Tube Jib	1,640	744		1				
Add 15' (4.6m) Tube Jib Extension	270	122					3	
Add 5' (1.5m) Auxiliary Tip Extension w/ Nylon Sheave	720	327						
Add 5' (1.5m) Auxiliary Tip Extension w/ Steel Sheave	1,000	454						
Add Pile Driver Lead Adaptor	198	90						
Add Hoist Rope - 26mm x 820' Type "YB"	1,870	848						
Add Jib Wire Rope - 26mm x 650' Type "YB"	1,482	672						
Add 3rd Drum Wire Rope - 0.75" x 550' type "DB"	572	259						
Add 4th Drum Wire Rope - 26mm x 620' type "RB"	1,147	520						
Add 15 Ton (13.6mt) Hook Ball (Non--swivel)	750	340						
Add 15 Ton (13.6mt) Hook Ball (Swivel)	767	348			1			
Add 30 Ton (27.3mt) 1 Sheave Quick Reeve Hook Block	1,700	771						
Add 90 Ton (81.8mt) 3 Sheave Quick Reeve Hook Block	2,400	1 089						
Add 130-ton (100mt) 4 Sheave Hook Block	3,300	1 497				1		
Remove Live Mast	-2,082	-944						
Remove 20' (6.1m) Tube Base Section w/ Backstops	-3,996	-1 813						
Remove Hoist Rope - 26mm x 820' Type "ZB"	-1,747	-792						
Remove Boom Hoist Rope - 20mm x 470' Type "DB"	-541	-245						
Remove Jib Wire Rope - 26mm x 650' Type "ZB"	-1,385	-628						
Remove 110 gal (416L) of Fuel	-797	-362						
Add Side Frames	45,316	20 555						1
Approximate Total Shipping Weight	lb		74,565	39,249	15,874	35,889	39,200	45,316
	kg		33,823	17,803	7,200	16,297	17,799	20,555

## Notes:

Estimated weights vary by  $\pm 2\%$ . Numbers in the load columns (numbers 1–5) represent quantities.

Estimated transport loads assume the load out consist of 230' (70.1m) of tube boom and 75' (22.86m) of jib with full counterweight.

Support loads were targeted at 45,000 lb (20 412kg), 8' 6" (2.6m) wide, 48' (14.6m) long, and 13' 6" (4.1m) high using a drop deck trailer. This may vary depending on state laws, empty truck/trailer weights, and style of trailer.

# Transport Drawings – Tube Boom

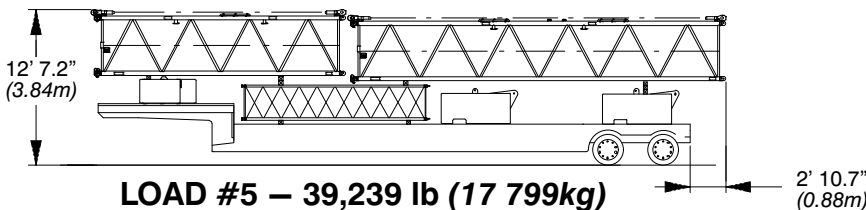
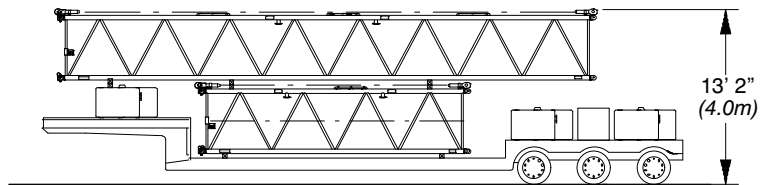
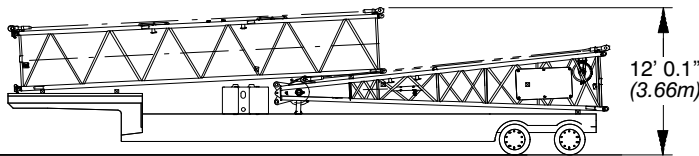
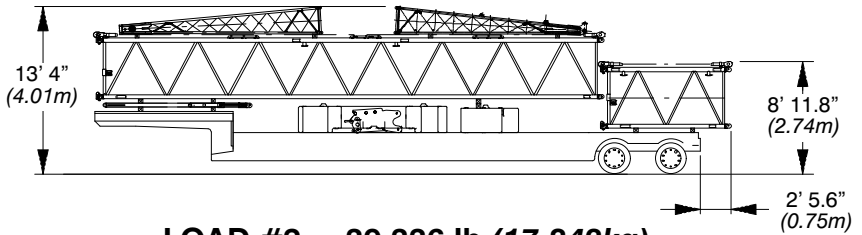
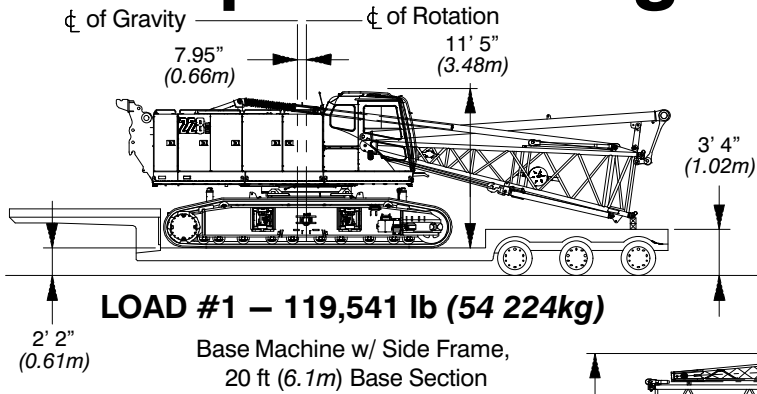

# Load Hoist Performance

## Front or Rear Drum – 26mm Wire Rope

Rope Layer	Maximum Line Pull		No Load Line Speed		Full Load Line Speed		Pitch Diameter		Layer		Total	
	lb	kg	ft/min	m/min	ft/min	m/min	in	mm	ft	m	ft	m
1	44,565	20 214	348	106	72	22	22.8	580	137.5	41.9	137.5	41.9
2	40,898	18 551	380	116	79	24	24.9	632	148.0	45.1	285.5	87.0
3	37,789	17 141	411	125	85	26	26.9	684	158.5	48.3	444.0	135.3
4	35,119	15 930	442	135	92	28	29.0	736	169.0	51.5	612.9	186.8
5	32,801	14 879	473	144	98	30	31.0	788	179.5	54.7	792.4	241.5
6	30,771	13 958	505	154	105	32	33.1	840	190.0	57.9	982.4	299.4
7	28,977	13 144	536	163	111	34	35.1	892	200.4	61.1	1 182.8	360.5

## Boom Hoist Drum – 20mm Wire Rope

Rope Layer	Maximum Line Pull		No Load Line Speed		Full Load Line Speed		Pitch Diameter		Layer		Total	
	lb	kg	ft/min	m/min	ft/min	m/min	in	mm	ft	m	ft	m
1	34,311	15 563	152	46	32	10	19.1	486	65.1	19.8	65.1	19.8
2	31,702	14 380	165	50	34	10	20.7	526	69.7	21.2	134.8	41.1
3	29,462	13 364	177	54	37	11	22.3	566	74.2	22.6	209.0	63.7
4	27,517	12 482	190	58	39	12	23.9	606	78.8	24.0	287.8	87.7
5	25,813	11 709	203	62	42	13	25.4	646	83.4	25.4	371.2	113.1
6	24,308	11 026	215	66	45	14	27.0	686	87.9	26.8	459.1	139.9
7	22,969	10 418	228	69	47	14	28.6	726	92.5	28.2	551.6	168.1

## Rear Mounted Fourth Drum – 26mm Wire Rope

Rope Layer	Maximum Line Pull		No Load Line Speed		Full Load Line Speed		Pitch Diameter		Layer		Total	
	lb	kg	ft/min	m/min	ft/min	m/min	in	mm	ft	m	ft	m
1	44,565	20 214	241	74	50	15	22.8	580	119.6	36.4	119.6	36.4
2	40,898	18 551	263	80	55	17	24.9	632	128.7	39.2	248.2	75.7
3	37,789	17 141	285	87	59	18	26.9	684	137.8	42.0	386.1	117.7
4	35,119	15 930	306	93	64	19	29.0	736	146.9	44.8	533.0	162.5
5	32,801	14 879	328	100	68	21	31.0	788	156.1	47.6	689.0	210.0

## Front Mounted Third Drum – 3/4" (19mm) Wire Rope

Rope Layer	Maximum Line Pull		No Load Line Speed		Full Load Line Speed		Pitch Diameter		Layer		Total	
	lb	kg	ft/min	m/min	ft/min	m/min	in	mm	ft	m	ft	m
1	23,000	10 433	160	48.8	102	31.1	13.5	343	80	24.4	80	24.4
2	20,700	9 390	178	54.3	114	34.7	15	381	89	27.1	169	51.5
3	18,820	8 537	196	59.7	125	38.1	16.5	419	98	29.9	267	81.4
4	17,250	7 825	214	65.2	137	41.8	18	457	107	32.6	374	114.0
5	15,925	7 224	232	70.7	148	45.1	19.5	495	116	35.4	490	149.4
6	14,785	6 706	249	75.9	160	48.8	21	533	124	37.8	614	187.1

Wire Rope Application	Diameter		Type	Max. Permissible Load		Wire Rope Descriptions
	in	mm		lb	kg	
Boom Hoist	--	20	DB	18,500	8 391	6 X 26 (6 X 19 Class), Warrington Seale, E.I.P.S., Preformed, Right Regular Lay, I.W.R.C.
Front Drum	--	26	ZB	29,200	13 224	34 X 7 Rotation Resistant – Extra Improved Plow Steele, Right Regular Lay or Right Lang Lay
Fourth Drum (Optional)	--	26	ZB	29,200	13 224	34 X 7 Rotation Resistant – Extra Improved Plow Steele, Right Regular Lay or Right Lang Lay
Rear Drum	--	26	ZB	29,200	13 224	18 X 19 Rotation Resistant Compacted Strand – High Strength – Preformed, Right Regular Lay
Third Drum (Optional)	3/4	19	DB	16,800	7 620	6 X 26 (6 X 19 Class), Warrington Seale, E.I.P.S., Preformed, Right Regular Lay, I.W.R.C.

# Working Areas

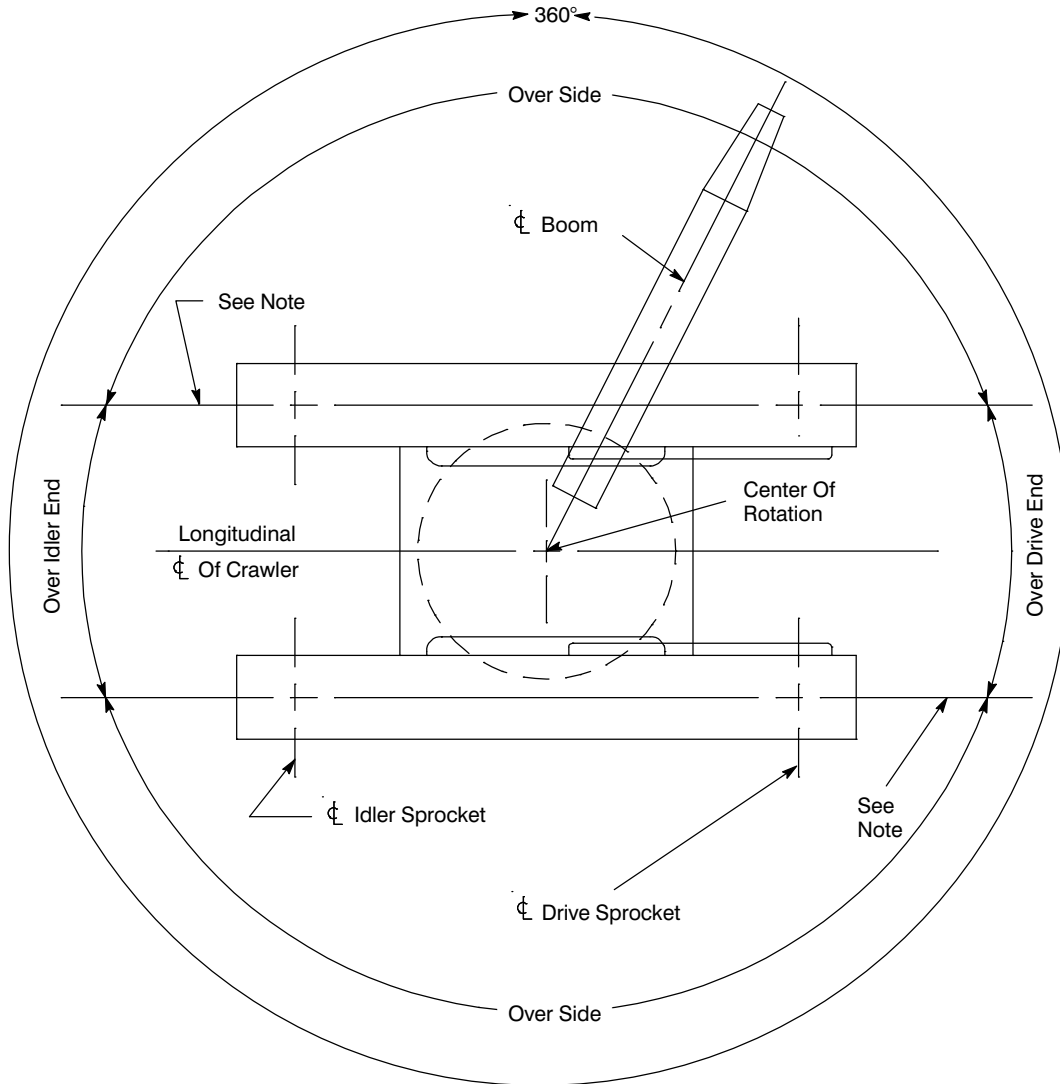

**Note:** These Lines Determine The Limiting Position Of Any Load For Operation Within Working Areas Indicated.

# Attachments

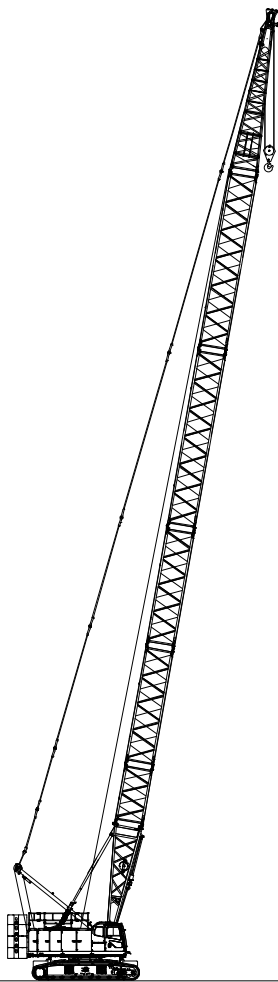

**45–155 ft (13.72–47.74m)  
Main Angle Boom**

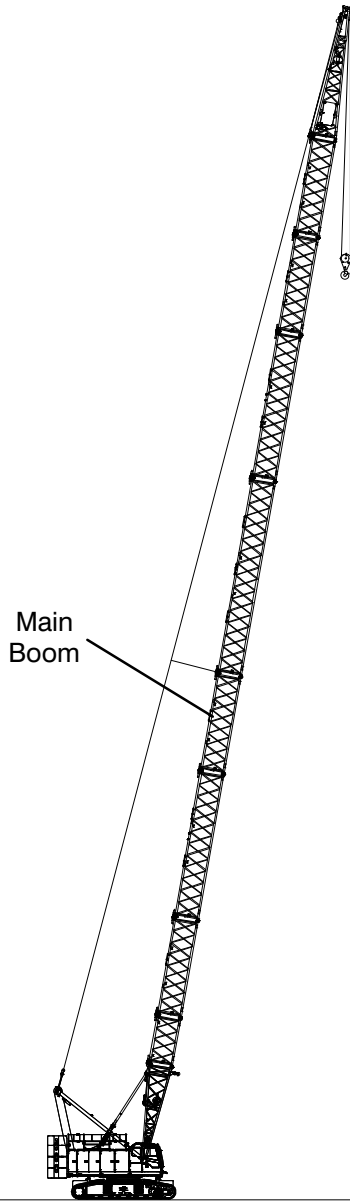

**45–235 ft (13.72–71.68m)  
Main Tube Boom**

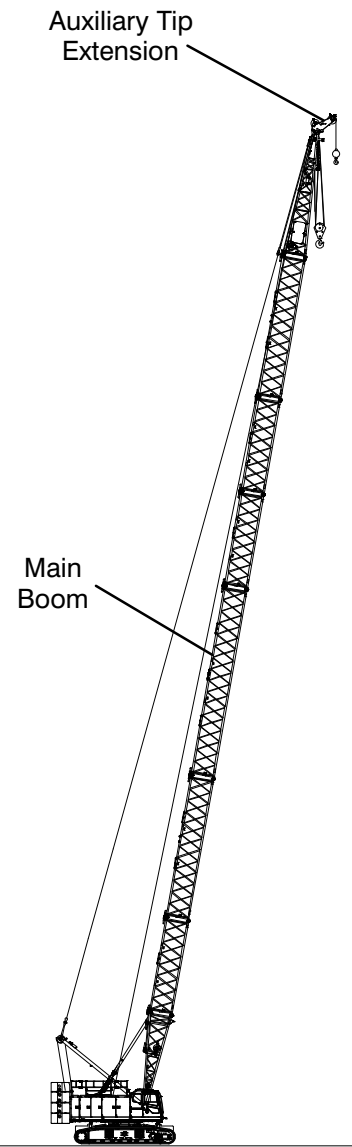

**45–205 ft (13.72–62.5m)  
Main Tube Boom With  
Auxiliary Tip Extension**

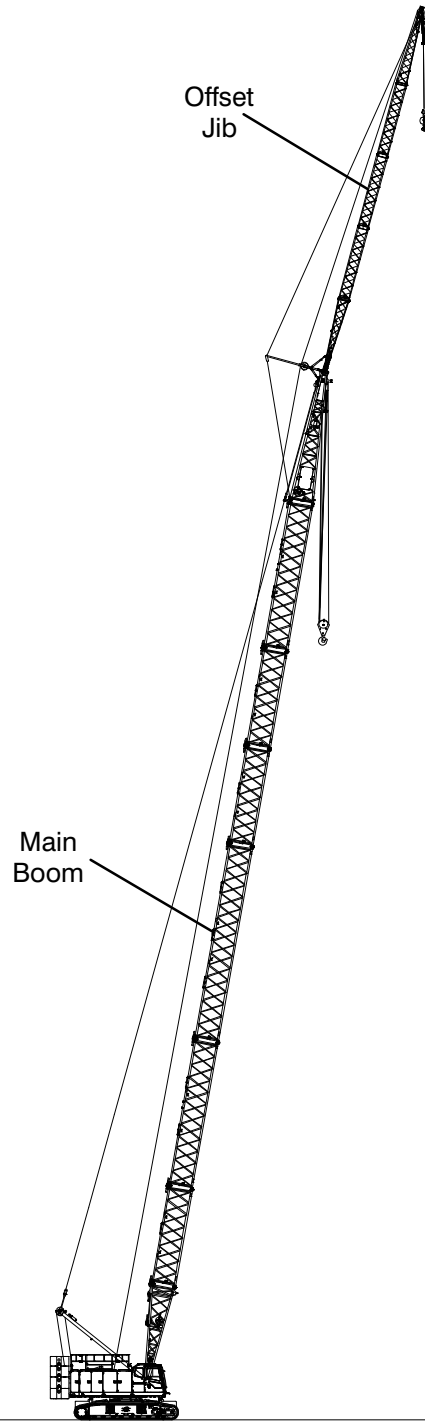

**45–205 ft (13.72–62.5m) Main  
Tube Boom With 30–75 ft  
(9.14–22.86m) Offset Jib**



# Main Boom Make–up

## Tube Boom Make–Up

Boom Length ft (m)	Tube Boom Extensions ft (m)			
	10 (3.05)	20 (6.14)	30 (9.10)	40 (12.19)
45 (13.72)				
55 (16.76)	1			
65 (19.81)		1		
75 (22.86)			1	
85 (25.91)				1
95 (28.96)	1			1
105 (32.00)		1		1
115 (35.05)			1	1
125 (38.10)				2
135 (41.15)	1			2
145 (44.20)		1		2
155 (47.24)			1	2
165 (50.29)	1		1	2
175 (53.34)		1	1	2
185 (56.39)	1	1	1	2
195 (59.44)	1		2	2
205 (62.48)		1	2	2
215 (65.53)	1	1	2	2
225 (68.58)		2	2	2
235 (71.63)	1	2	2	2

### Notes:

- Capacities shown are in kips/metric tons (1 kip = 1,000 lb / 1 metric ton = 0.45 kips) and are not more than 75% of the tipping loads with the crane standing level on firm supporting surface. A deduction must be made from these capacities for weight of hook block, hook ball, sling, grapple, load weighing device, etc. When using main hook while jib or tip extension is attached, reduce capacities by values shown in Crane Rating Manual. See Operator's Manual for all limitations when raising or lowering attachment.
- The capacities in the shaded areas are based on structural strength. The capacities in the non–shaded areas are based on stability ratings.
- For recommended reeving, parts of line, wire rope type, and wire rope inspection, see Wire Rope Capacity Chart, Operator's Manual, and Parts Manual.
- Load ratings are based on freely suspended loads and make no allowances for such factors as the effect of the wind, ground conditions, and operating speeds. The operator shall therefore reduce load ratings in order to take these conditions into account. Refer to the Crane Rating Manual for Wind Speed Restrictions.
- The 26 ft (7.92m) live mast must be used for all capacities listed.
- The least stable rated condition is over the side.
- Booms must be erected and lowered over the end for maximum stability.
- Main boom length must not exceed 235 ft (71.63m).

### Optional Auxiliary Tip Extension

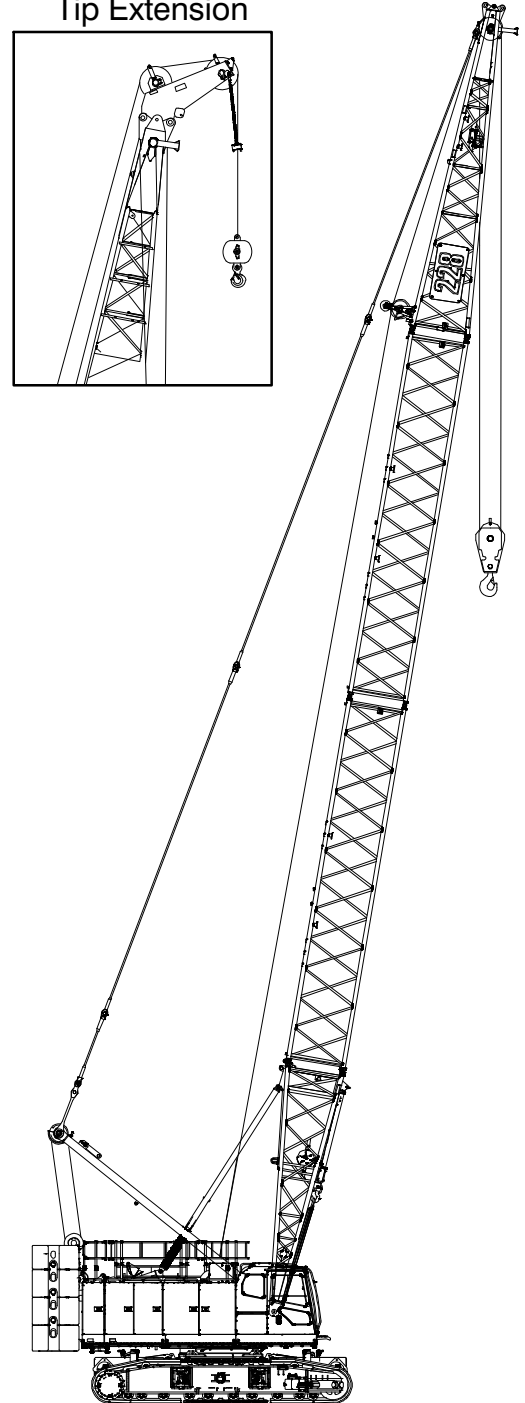

## Angle Boom Make–Up

Boom Length ft (m)	Angle Boom Extensions ft (m)		
	10 (3.05)	20 (6.14)	30 (9.10)
45 (13.72)			
55 (16.76)	1		
65 (19.81)		1	
75 (22.86)			1
85 (25.91)	1		1
95 (28.96)		1	1
105 (32.00)			2
115 (35.05)	1		2
125 (38.10)		1	2
135 (41.15)			3
145 (44.20)	1		3
155 (47.24)		1	3

### Notes:

- Capacities shown are in kips/metric tons (1 kip = 1,000 lb / 1 metric ton = 0.45 kips) and are not more than 75% of the tipping loads with the crane standing level on firm supporting surface. A deduction must be made from these capacities for weight of hook block, hook ball, sling, grapple, load weighing device, etc. When using main hook while jib or tip extension is attached, reduce capacities by values shown in Crane Rating Manual. See Operator's Manual for all limitations when raising or lowering attachment.
- The capacities in the shaded areas are based on structural strength. The capacities in the non-shaded areas are based on stability ratings.
- For recommended reeving, parts of line, wire rope type, and wire rope inspection, see Wire Rope Capacity Chart, Operator's Manual, and Parts Manual.
- Load ratings are based on freely suspended loads and make no allowances for such factors as the effect of the wind, ground conditions, and operating speeds. The operator shall therefore reduce load ratings in order to take these conditions into account. Refer to the Crane Rating Manual for Wind Speed Restrictions.
- The 22 ft (6.71m) live mast must be used for all capacities listed.
- The least stable rated condition is over the side.
- Booms must be erected and lowered over the end for maximum stability.
- Main boom length must not exceed 155 ft (47.24m).
- Do not operate at radii and boom lengths where the Crane Rating Manual lists no capacity. Do not use longer booms or jibs than those listed in the Crane Rating Manual. Any of the above can cause a tipping condition, or boom and jib failure.
- These capacities are in compliance with ASME/ANSI B30.5 at date of manufacture.
- These capacities apply only to the crane as originally manufactured and normally equipped by Link-Belt Construction Equipment Company.

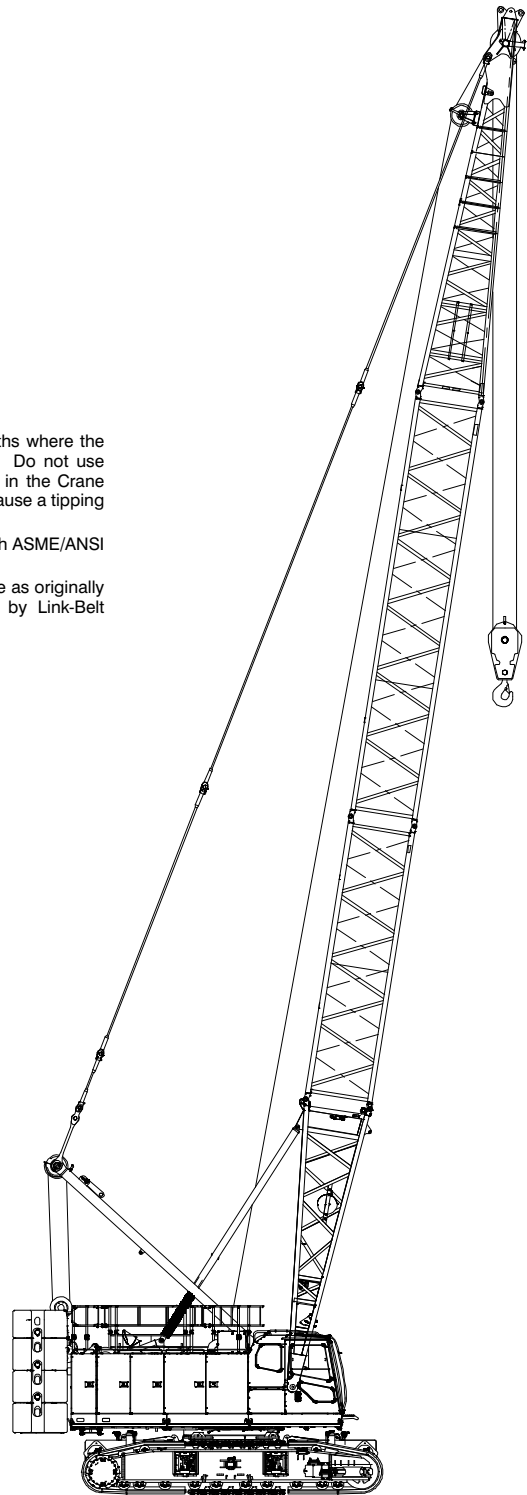

# Main Boom Working Range Diagram

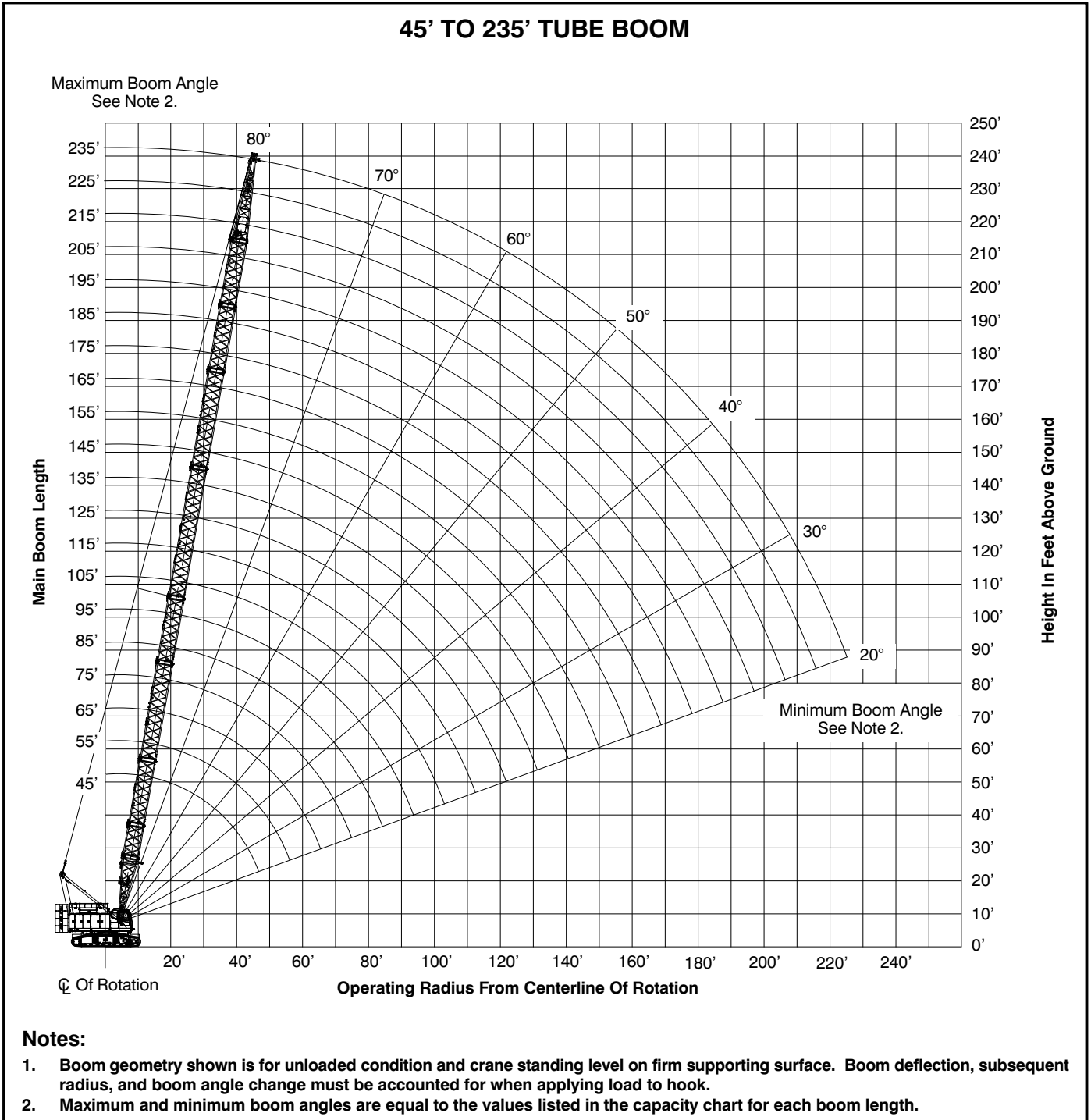

# Main Boom Load Chart

<b>Tube Boom Lift Capacity Chart – 360° Rotation</b> <b>ABCD+A [80,000+26,500 lb (36 364+12 040kg)] Counterweight – Side Frames Extended</b> <b>[All capacities are listed in kips (mt)]</b>										
Load Radius ft (m)	Boom Length – ft (m)									
	45 (13.8)	55 (16.8)	65 (19.9)	75 (22.9)	85 (26)	95 (29)	105 (32.1)	115 (35.1)	125 (38.2)	135 (41.2)
12 (3.7)	260 (118.2)									
13 (4)	242 (110)									
14 (4.3)	226.1 (102.8)	225.1 (102.4)								
15 (4.6)	212 (96.4)	211.2 (96)								
16 (4.9)	199.7 (90.8)	198.9 (90.5)	198 (90)							
17 (5.2)	188.6 (85.8)	187.9 (85.5)	187.1 (85.1)							
18 (5.5)	178.6 (81.2)	178 (81)	177.2 (80.6)	176.4 (80.2)						
19 (5.8)	169.7 (77.2)	169.1 (76.9)	168.5 (76.6)	167.7 (76.3)						
20 (6.1)	161.6 (73.5)	161 (73.2)	160.4 (73)	159.7 (72.6)	158.9 (72.3)					
25 (7.7)	117 (53.2)	117 (53.2)	116.8 (53.1)	116.6 (53)	116.4 (53)	116.2 (52.9)	115.9 (52.7)	115.7 (52.6)		
30 (9.2)	90.5 (41.2)	90.4 (41.1)	90.2 (41)	90 (41)	89.8 (40.9)	89.5 (40.7)	89.2 (40.6)	89 (40.5)	88.7 (40.4)	88.4 (40.2)
35 (10.7)	73.6 (33.5)	73.5 (33.5)	73.4 (33.4)	73.2 (33.3)	72.9 (33.2)	72.7 (33.1)	72.4 (33)	72.1 (32.8)	71.9 (32.7)	71.6 (32.6)
40 (12.2)	61.8 (28.1)	61.7 (28.1)	61.6 (28)	61.3 (27.9)	61.1 (27.8)	60.8 (27.7)	60.6 (27.6)	60.3 (27.5)	60 (27.3)	59.7 (27.2)
50 (15.3)		46.5 (21.2)	46.3 (21.1)	46.1 (21)	45.9 (20.9)	45.6 (20.8)	45.4 (20.7)	45.1 (20.5)	44.8 (20.4)	44.5 (20.3)
60 (18.3)			36.8 (16.8)	36.6 (16.7)	36.4 (16.6)	36.1 (16.5)	35.8 (16.3)	35.5 (16.2)	35.3 (16.1)	35 (16)
70 (21.4)				30.1 (13.7)	29.9 (13.6)	29.6 (13.5)	29.3 (13.4)	29.3 (13.4)	29 (13.2)	28.7 (13.1)
80 (24.4)					25.3 (11.5)	25 (11.4)	24.8 (11.3)	24.5 (11.2)	24.2 (11)	24 (11)
90 (27.5)						21.4 (9.8)	21.2 (9.7)	20.9 (9.5)	20.7 (9.5)	20.4 (9.3)
100 (30.5)							18.4 (8.4)	18.1 (8.3)	17.8 (8.1)	17.6 (8)
110 (33.6)								15.9 (7.3)	15.6 (7.1)	15.3 (7)
120 (36.6)									13.7 (6.3)	13.4 (6.1)
130 (39.7)										11.9 (5.5)

This material is supplied for reference use only. Operator must refer to in-cab Crane Rating Manual and Operator's Manual to determine allowable crane lifting capacities and assembly and operating procedures.

**Tube Boom Lift Capacity Chart – 360° Rotation**  
**ABCD+A [80,000+26,500 lb (36 364+12 040kg)] Counterweight – Side Frames Extended**  
 [All capacities are listed in kips (mT)]

Load Radius ft (m)	Boom Length – ft (m)									
	145 (44.3)	155 (47.3)	165 (50.4)	175 (53.4)	185 (56.5)	195 (59.5)	205 (62.5)	215 (65.6)	225 (68.6)	235 (71.7)
30 (9.2)	88.1 (40.1)									
35 (10.7)	71.3 (32.5)	71 (32.3)	70.7 (32.2)	67.8 (30.9)						
40 (12.2)	59.4 (27)	59.1 (26.9)	58.8 (26.8)	58.5 (26.6)	57.2 (26)	50.8 (23.1)	45.4 (20.7)			
50 (15.3)	44.3 (20.2)	44 (20)	43.7 (19.9)	43.4 (19.8)	43.1 (19.6)	42.8 (19.5)	42.5 (19.4)	40.9 (18.6)	36.5 (16.6)	32.8 (15)
60 (18.3)	34.7 (15.8)	34.4 (15.7)	34.1 (15.5)	33.8 (15.4)	33.5 (15.3)	33.2 (15.1)	32.9 (15)	32.5 (14.8)	32.2 (14.7)	31.9 (14.5)
70 (21.4)	28.4 (13)	28.2 (12.9)	27.9 (12.7)	27.6 (12.6)	27.3 (12.5)	27 (12.3)	26.7 (12.2)	26.4 (12)	26.1 (11.9)	25.8 (11.8)
80 (24.4)	23.7 (10.8)	23.4 (10.7)	23.1 (10.5)	22.8 (10.4)	22.5 (10.3)	22.2 (10.1)	22 (10)	21.6 (9.9)	21.3 (9.7)	21 (9.6)
90 (27.5)	20.1 (9.2)	19.8 (9)	19.5 (8.9)	19.2 (8.8)	18.9 (8.6)	18.6 (8.5)	18.3 (8.4)	18 (8.2)	17.7 (8.1)	17.4 (8)
100 (30.5)	17.3 (7.9)	17 (7.8)	16.7 (7.6)	16.4 (7.5)	16.1 (7.4)	15.8 (7.2)	15.5 (7.1)	15.2 (7)	14.9 (6.8)	14.6 (6.7)
110 (33.6)	15 (6.9)	14.7 (6.7)	14.4 (6.6)	14.1 (6.5)	13.8 (6.3)	13.5 (6.2)	13.2 (6)	12.9 (5.9)	12.6 (5.8)	12.3 (5.6)
120 (36.6)	13.2 (6)	12.9 (5.9)	12.6 (5.8)	12.3 (5.6)	12 (5.5)	11.7 (5.4)	11.4 (5.2)	11 (5)	10.7 (4.9)	10.4 (4.8)
130 (39.7)	11.6 (5.3)	11.3 (5.2)	11 (5)	10.7 (4.9)	10.4 (4.8)	10.1 (4.6)	9.8 (4.5)	9.5 (4.4)	9.2 (4.2)	8.8 (4)
140 (42.7)	10.3 (4.7)	10 (4.6)	9.7 (4.5)	9.4 (4.3)	9.1 (4.2)	8.8 (4)	8.5 (3.9)	8.1 (3.7)	7.8 (3.6)	7.5 (3.5)
150 (45.8)			8.6 (4)	8.3 (3.8)	7.9 (3.6)	7.6 (3.5)	7.3 (3.4)	7 (3.2)	6.7 (3.1)	6.4 (3)
160 (48.8)				7.3 (3.4)	7 (3.2)	6.7 (3.1)	6.3 (2.9)	6 (2.8)	5.7 (2.6)	5.4 (2.5)
170 (51.9)					6.1 (2.8)	5.8 (2.7)	5.5 (2.5)	5.1 (2.4)	4.8 (2.2)	4.5 (2.1)
180 (54.9)						5 (2.3)	4.7 (2.2)	4.4 (2)	4.1 (1.9)	3.8 (1.8)
190 (58)							4.1 (1.9)	3.7 (1.7)	3.4 (1.6)	3.1 (1.5)
200 (61)								3.1 (1.5)	2.8 (1.3)	2.5 (1.2)
210 (64.1)									2.3 (1.1)	1.9 (0.9)
220 (67.1)										1.5 (0.7)

This material is supplied for reference use only. Operator must refer to in-cab Crane Rating Manual and Operator's Manual to determine allowable crane lifting capacities and assembly and operating procedures.

# Jib Attachment Make-up

Jib Length ft (m)	Jib Extensions	Basic Frontstay Pendants Required	Pairs Of Frontstay Extension Pendants Required
	15 ft (4.57 m)	63 ft 5 in (19.33m)	14 ft 6 in (4.42m)
30 (9.15)		1	
45 (13.72)	1	1	1
60 (18.29)	2	1	2
75 (22.86)	3	1	3

## Notes:

1. Capacities shown are in kips/metric tons (1 kip = 1,000 lb / 1 metric ton = 0.45 kips) and are not more than 75% of the tipping loads with the crane standing level on a firm supporting surface.
2. A deduction must be made from these capacities for the weight of the main boom hook block or hook ball, jib hook block or hook ball, slings, grapples, load weighing devices, etc. When using main hook while jib is attached, reduce capacities by values shown in Crane Rating Manual. See Operator's Manual for all limitations when raising or lowering attachment.
3. The capacities in the shaded areas are based on structural strength. The capacities in the non-shaded areas are based on stability ratings.
4. Load ratings are based on freely suspended loads and make no allowances for such factors as the effect of the wind, ground conditions, and operating speeds. The operator shall therefore reduce load ratings in order to take these conditions into account. Refer to the Crane Rating Manual for Wind Speed Restrictions.
5. These capacities are for "ABC+A" counterweight.
6. These capacities are for 360° working areas.
7. These capacities are for 30–75 ft (9.15–22.86m) jib lengths only.
8. The jib cannot be used on boom lengths over 205 ft (62.5m).
9. The least stable rated condition is over the side.
10. These capacities are in compliance with ASME/ANSI B30.5 at date of manufacture.
11. These capacities apply only to the crane as originally manufactured and normally equipped by Link-Belt Construction Equipment Company.

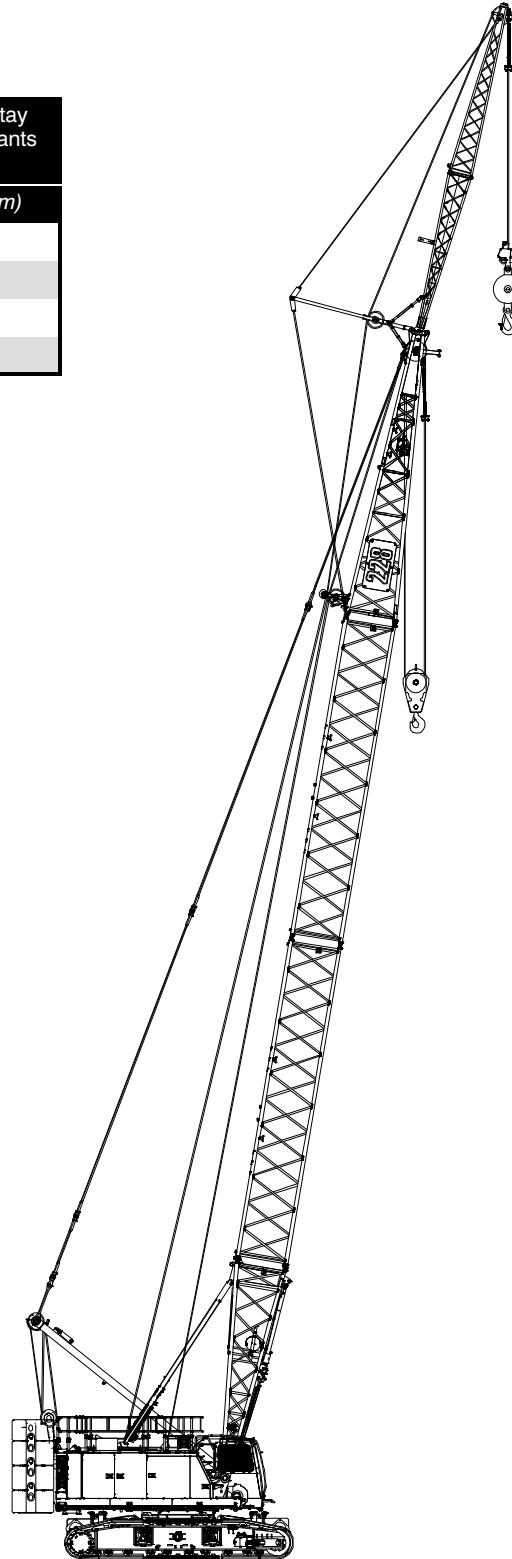

# Jib Attachment Working Range Diagram

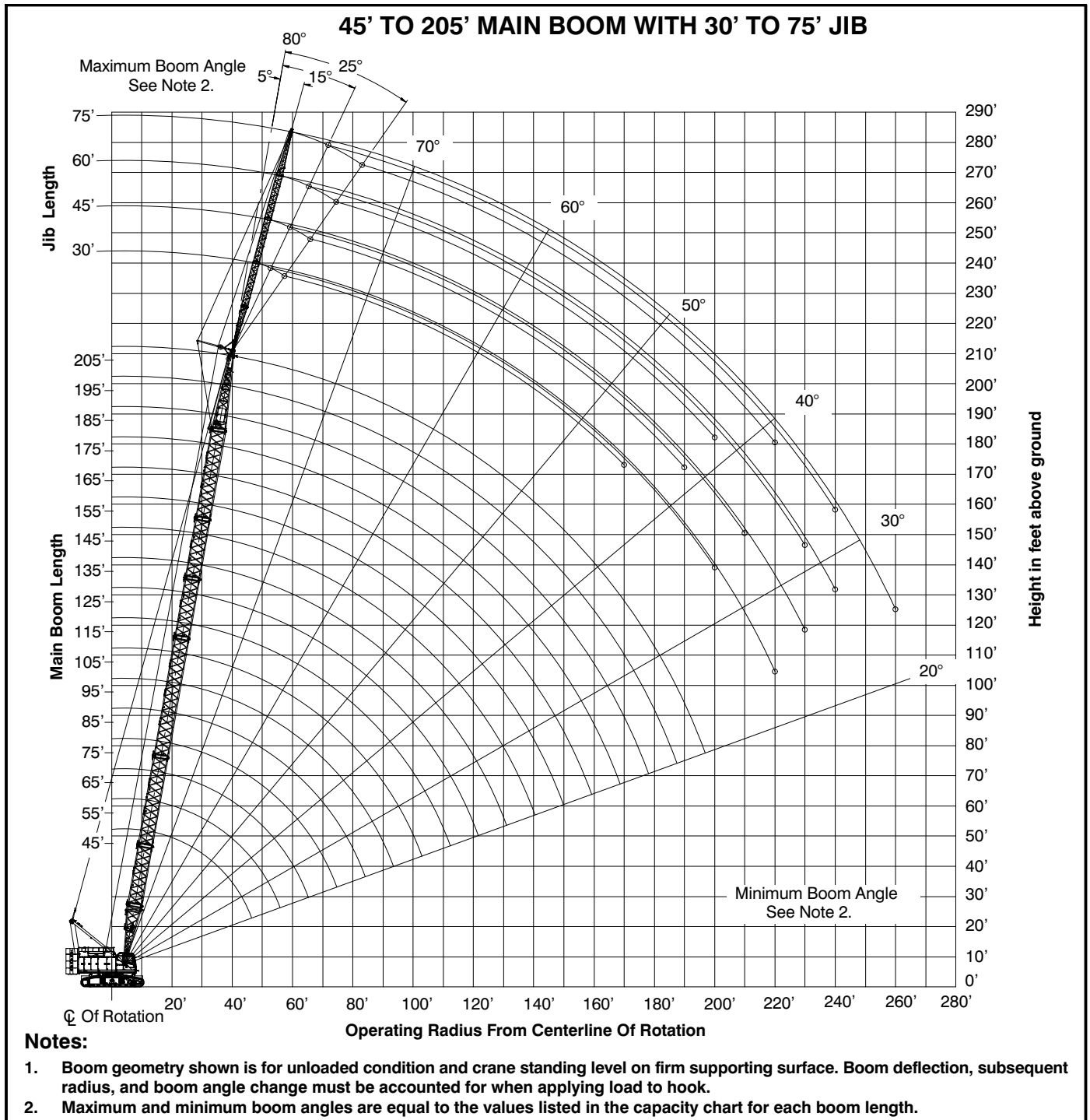

# Jib Attachment Load Charts

30 ft (9.14m) Offset Jib Length – 360° Rotation – ABCD+A [80,000+26,500 lb (36 364+12 040kg)] Counterweight [All capacities are listed in kips (mt)]																	
5° Offset						15° Offset						25° Offset					
Load Radius ft (m)	Main Boom Length ft (m)					Load Radius ft (m)	Main Boom Length ft (m)					Load Radius ft (m)	Main Boom Length ft (m)				
	45 (13.8)	105 (32.1)	145 (44.3)	185 (56.5)	205 (62.5)		45 (13.8)	105 (32.1)	145 (44.3)	185 (56.5)	205 (62.5)		45 (13.8)	105 (32.1)	145 (44.3)	185 (56.5)	205 (62.5)
20 (6.1)	24.0 (11)					20 (6.1)						20 (6.1)					
25 (7.7)	24.0 (11)					25 (7.7)						25 (7.7)					
30 (9.2)	24.0 (11)					30 (9.2)	24.0 (11)					30 (9.2)	22.1 (10.1)				
35 (10.7)	24.0 (11)	24.0 (11)				35 (10.7)	24.0 (11)					35 (10.7)	20.3 (9.3)				
40 (12.2)	24.0 (11)	24.0 (11)	24.0 (11)			40 (12.2)	24.0 (11)	24.0 (11)				40 (12.2)	18.7 (8.5)				
50 (15.3)	24.0 (11)	24.0 (11)	24.0 (11)	24.0 (11)	24.0 (11)	50 (15.3)	21.3 (9.7)	24.0 (11)	24.0 (11)	24.0 (11)		50 (15.3)	16.3 (7.5)	20.0 (9.1)	21.4 (9.8)		
60 (18.3)	21.8 (10)	24.0 (11)	24.0 (11)	24.0 (11)	24.0 (11)	60 (18.3)	18.0 (8.2)	24.0 (11)	24.0 (11)	24.0 (11)	24.0 (11)	60 (18.3)	14.6 (6.7)	18.4 (8.4)	19.9 (9.1)	21.0 (9.6)	21.4 (9.8)
70 (21.4)	18.3 (8.4)	24.0 (11)	24.0 (11)	23.1 (10.5)	22.5 (10.3)	70 (21.4)	15.7 (7.2)	23.8 (10.9)	24.0 (11)	23.6 (10.8)	23.1 (10.5)	70 (21.4)		17.0 (7.8)	18.6 (8.5)	19.8 (9)	20.3 (9.3)
80 (24.4)		21.1 (9.6)	20 (9.1)	18.9 (8.6)	18.3 (8.4)	80 (24.4)		21.3 (9.7)	20.3 (9.3)	19.3 (8.8)	18.8 (8.6)	80 (24.4)		15.9 (7.3)	17.5 (8)	18.7 (8.5)	19.2 (8.8)
90 (27.5)		18 (8.2)	16.9 (7.7)	15.7 (7.2)	15.1 (6.9)	90 (27.5)		18.2 (8.3)	17.1 (7.8)	16.1 (7.4)	15.5 (7.1)	90 (27.5)		15.0 (6.9)	16.6 (7.6)	16.4 (7.5)	15.9 (7.3)
100 (30.5)		15.5 (7.1)	14.4 (6.6)	13.2 (6)	12.6 (5.8)	100 (30.5)		15.7 (7.2)	14.6 (6.7)	13.5 (6.2)	13 (6)	100 (30.5)		14.3 (6.5)	14.8 (6.8)	13.8 (6.3)	13.3 (6.1)
110 (33.6)		13.5 (6.2)	12.4 (5.7)	11.2 (5.1)	10.6 (4.9)	110 (33.6)		13.6 (6.2)	12.6 (5.8)	11.5 (5.3)	10.9 (5)	110 (33.6)			12.7 (5.8)	11.7 (5.4)	11.2 (5.1)
120 (36.6)		11.9 (5.5)	10.7 (4.9)	9.5 (4.4)	9 (4.1)	120 (36.6)		12 (5.5)	10.9 (5)	9.8 (4.5)	9.2 (4.2)	120 (36.6)			11 (5)	10 (4.6)	9.5 (4.4)
130 (39.7)			9.3 (4.3)	8.2 (3.8)	7.6 (3.5)	130 (39.7)			9.5 (4.4)	8.4 (3.9)	7.8 (3.6)	130 (39.7)			9.6 (4.4)	8.5 (3.9)	8 (3.7)
140 (42.7)			8.2 (3.8)	7 (3.2)	6.4 (3)	140 (42.7)			8.3 (3.8)	7.2 (3.3)	6.6 (3)	140 (42.7)				7.3 (3.4)	6.8 (3.1)
150 (45.8)			7.2 (3.3)	6 (2.8)	5.4 (2.5)	150 (45.8)			7.3 (3.4)	6.1 (2.8)	5.6 (2.6)	150 (45.8)				6.3 (2.9)	5.7 (2.6)
160 (48.8)			6.3 (2.9)	5.1 (2.4)	4.5 (2.1)	160 (48.8)				5.2 (2.4)	4.7 (2.2)	160 (48.8)				5.3 (2.5)	4.8 (2.2)
170 (51.9)				4.3 (2)	3.7 (1.7)	170 (51.9)				4.5 (2.1)	3.9 (1.8)	170 (51.9)					4 (1.9)
180 (54.9)				3.7 (1.7)	3.1 (1.5)	180 (54.9)				3.8 (1.8)	3.2 (1.5)	180 (54.9)					
190 (58)				3.1 (1.5)		190 (58)						190 (58)					
200 (61)						200 (61)						200 (61)					

This material is supplied for reference use only. Operator must refer to in-cab Crane Rating Manual and Operator's Manual to determine allowable crane lifting capacities and assembly and operating procedures.



45 ft (13.72m) Offset Jib Length – 360° Rotation – ABCD+A [80,000+26,500 lb (36 364+12 040kg)] Counterweight [All capacities are listed in kips (mt)]																	
5° Offset						15° Offset					25° Offset						
Load Radius ft (m)	Main Boom Length ft (m)					Load Radius ft (m)	Main Boom Length ft (m)					Load Radius ft (m)	Main Boom Length ft (m)				
	45 (13.8)	105 (32.1)	145 (44.3)	185 (56.5)	205 (62.5)		45 (13.8)	105 (32.1)	145 (44.3)	185 (56.5)	200 (61.0)		45 (13.8)	105 (32.1)	145 (44.3)	185 (56.5)	205 (62.5)
25 (7.7)	24.0 (11)					25 (7.7)						25 (7.7)					
30 (9.2)	24.0 (11)					30 (9.2)						30 (9.2)					
35 (10.7)	24.0 (11)	24.0 (11)				35 (10.7)	21.5 (9.8)					35 (10.7)					
40 (12.2)	24.0 (11)	24.0 (11)				40 (12.2)	19.0 (8.7)					40 (12.2)	14.3 (6.5)				
50 (15.3)	19.6 (9)	24.0 (11)	24.0 (11)	24.0 (11)		50 (15.3)	15.4 (7)	20.7 (9.5)	23.1 (10.5)			50 (15.3)	12.0 (5.5)	14.4 (6.6)			
60 (18.3)	15.9 (7.3)	24.0 (11)	24.0 (11)	24.0 (11)	24.0 (11)	60 (18.3)	13.0 (6)	17.9 (8.2)	20.4 (9.3)	22.3 (10.2)	23.2 (10.6)	60 (18.3)	10.4 (4.8)	12.9 (5.9)	14.0 (6.4)		
70 (21.4)	13.4 (6.1)	21.7 (9.9)	24.0 (11)	23.4 (10.7)	22.9 (10.5)	70 (21.4)	11.2 (5.1)	15.8 (7.2)	18.2 (8.3)	20.1 (9.2)	21.0 (9.6)	70 (21.4)	9.2 (4.2)	11.8 (5.4)	12.9 (5.9)	13.7 (6.3)	14.0 (6.4)
80 (24.4)	11.6 (5.3)	18.8 (8.6)	20.3 (9.3)	19.2 (8.8)	18.6 (8.5)	80 (24.4)	10.0 (4.6)	14.2 (6.5)	16.4 (7.5)	18.3 (8.4)	19.2 (8.8)	80 (24.4)	8.4 (3.9)	10.8 (5)	11.9 (5.5)	12.8 (5.9)	13.1 (6)
90 (27.5)		16.6 (7.6)	17.1 (7.8)	16 (7.3)	15.4 (7)	90 (27.5)		12.9 (5.9)	15.0 (6.9)	16.5 (7.5)	16 (7.3)	90 (27.5)		10.0 (4.6)	11.1 (5.1)	12.0 (5.5)	12.4 (5.7)
100 (30.5)		14.8 (6.8)	14.6 (6.7)	13.5 (6.2)	12.9 (5.9)	100 (30.5)		11.8 (5.4)	13.8 (6.3)	13.9 (6.4)	13.4 (6.1)	100 (30.5)		9.4 (4.3)	10.4 (4.8)	11.3 (5.2)	11.7 (5.4)
110 (33.6)		13.4 (6.1)	12.6 (5.8)	11.5 (5.3)	10.9 (5)	110 (33.6)		10.9 (5)	12.8 (5.9)	11.9 (5.5)	11.3 (5.2)	110 (33.6)		8.8 (4)	9.9 (4.5)	10.7 (4.9)	11.1 (5.1)
120 (36.6)		12.1 (5.5)	11 (5)	9.8 (4.5)	9.2 (4.2)	120 (36.6)		10.2 (4.7)	11.2 (5.1)	10.1 (4.6)	9.6 (4.4)	120 (36.6)		8.4 (3.9)	9.4 (4.3)	10.2 (4.7)	10 (4.6)
130 (39.7)		10.7 (4.9)	9.6 (4.4)	8.4 (3.9)	7.8 (3.6)	130 (39.7)		9.6 (4.4)	9.8 (4.5)	8.7 (4)	8.2 (3.8)	130 (39.7)			8.9 (4.1)	9 (4.1)	8.5 (3.9)
140 (42.7)		9.6 (4.4)	8.4 (3.9)	7.2 (3.3)	6.6 (3)	140 (42.7)			8.6 (4)	7.5 (3.5)	6.9 (3.2)	140 (42.7)			8.6 (4)	7.7 (3.5)	7.2 (3.3)
150 (45.8)			7.4 (3.4)	6.2 (2.9)	5.6 (2.6)	150 (45.8)			7.6 (3.5)	6.4 (3)	5.9 (2.7)	150 (45.8)			7.7 (3.5)	6.7 (3.1)	6.1 (2.8)
160 (48.8)			6.5 (3)	5.3 (2.5)	4.7 (2.2)	160 (48.8)			6.6 (3)	5.5 (2.5)	5 (2.3)	160 (48.8)				5.7 (2.6)	5.2 (2.4)
170 (51.9)			5.8 (2.7)	4.6 (2.1)	4 (1.9)	170 (51.9)				4.7 (2.2)	4.2 (2)	170 (51.9)				4.9 (2.3)	4.4 (2)
180 (54.9)			5.1 (2.4)	3.9 (1.8)	3.3 (1.5)	180 (54.9)				4 (1.9)	3.5 (1.6)	180 (54.9)					3.6 (1.7)
190 (58)				3.3 (1.5)		190 (58)				3.4 (1.6)		190 (58)					3 (1.4)
200 (61)						200 (61)						200 (61)					

This material is supplied for reference use only. Operator must refer to in-cab Crane Rating Manual and Operator's Manual to determine allowable crane lifting capacities and assembly and operating procedures.

60 ft (18.29m) Offset Jib Length – 360° Rotation – ABCD+A [80,000+26,500 lb (36 364+12 040kg)] Counterweight [All capacities are listed in kips (mt)]																	
Load Radius ft (m)	5° Offset					Load Radius ft (m)	15° Offset					Load Radius ft (m)	25° Offset				
	Main Boom Length ft (m)						Main Boom Length ft (m)						Main Boom Length ft (m)				
	45 (13.8)	105 (32.1)	145 (44.3)	185 (56.5)	205 (62.5)		45 (13.8)	105 (32.1)	145 (44.3)	185 (56.5)	200 (61.0)		45 (13.8)	105 (32.1)	145 (44.3)	185 (56.5)	205 (62.5)
30 (9.2)	23.9 (10.9)					30 (9.2)						30 (9.2)					
35 (10.7)	22.8 (10.4)					35 (10.7)						35 (10.7)					
40 (12.2)	20.4 (9.3)	23.3 (10.6)				40 (12.2)	15.2 (7)					40 (12.2)					
50 (15.3)	15.8 (7.2)	22.1 (10.1)	22.2 (10.1)			50 (15.3)	12.3 (5.6)	15.4 (7)				50 (15.3)	9.5 (4.4)				
60 (18.3)	12.8 (5.9)	19.2 (8.8)	21.3 (9.7)	20.9 (9.5)	20.3 (9.3)	60 (18.3)	10.3 (4.7)	13.4 (6.1)	14.9 (6.8)			60 (18.3)	8.2 (3.8)	9.6 (4.4)			
70 (21.4)	10.8 (5)	16.4 (7.5)	19.8 (9)	20.2 (9.2)	19.7 (9)	70 (21.4)	8.9 (4.1)	11.9 (5.5)	13.3 (6.1)	14.5 (6.6)	15.0 (6.9)	70 (21.4)	7.2 (3.3)	8.7 (4)	9.3 (4.3)		
80 (24.4)	9.3 (4.3)	14.2 (6.5)	17.2 (7.9)	19.4 (8.9)	18.9 (8.6)	80 (24.4)	7.8 (3.6)	10.6 (4.9)	12.0 (5.5)	13.2 (6)	13.7 (6.3)	80 (24.4)	6.4 (3)	7.9 (3.6)	8.6 (4)	9.1 (4.2)	9.3 (4.3)
90 (27.5)	8.2 (3.8)	12.5 (5.7)	15.3 (7)	16.2 (7.4)	15.7 (7.2)	90 (27.5)	7.0 (3.2)	9.6 (4.4)	11.0 (5)	12.1 (5.5)	12.6 (5.8)	90 (27.5)	5.8 (2.7)	7.3 (3.4)	8.0 (3.7)	8.5 (3.9)	8.8 (4)
100 (30.5)	7.3 (3.4)	11.2 (5.1)	13.7 (6.3)	13.7 (6.3)	13.1 (6)	100 (30.5)		8.8 (4)	10.1 (4.6)	11.2 (5.1)	11.7 (5.4)	100 (30.5)		6.8 (3.1)	7.5 (3.5)	8.0 (3.7)	8.3 (3.8)
110 (33.6)		10.1 (4.6)	12.4 (5.7)	11.7 (5.4)	11.1 (5.1)	110 (33.6)		8.1 (3.7)	9.3 (4.3)	10.4 (4.8)	10.9 (5)	110 (33.6)		6.4 (3)	7.1 (3.3)	7.6 (3.5)	7.8 (3.6)
120 (36.6)		9.2 (4.2)	11.1 (5.1)	10 (4.6)	9.4 (4.3)	120 (36.6)		7.5 (3.5)	8.7 (4)	9.7 (4.5)	9.9 (4.5)	120 (36.6)		6.0 (2.8)	6.7 (3.1)	7.2 (3.3)	7.4 (3.4)
130 (39.7)		8.5 (3.9)	9.7 (4.5)	8.6 (4)	8 (3.7)	130 (39.7)		7.0 (3.2)	8.1 (3.7)	9 (4.1)	8.5 (3.9)	130 (39.7)		5.7 (2.6)	6.3 (2.9)	6.9 (3.2)	7.1 (3.3)
140 (42.7)		7.9 (3.6)	8.6 (4)	7.4 (3.4)	6.8 (3.1)	140 (42.7)		6.6 (3)	7.7 (3.5)	7.8 (3.6)	7.2 (3.3)	140 (42.7)			6.0 (2.8)	6.5 (3)	6.8 (3.1)
150 (45.8)		7.3 (3.4)	7.6 (3.5)	6.4 (3)	5.8 (2.7)	150 (45.8)			7.2 (3.3)	6.7 (3.1)	6.2 (2.9)	150 (45.8)			5.8 (2.7)	6.3 (2.9)	6.5 (3)
160 (48.8)			6.7 (3.1)	5.5 (2.5)	4.9 (2.3)	160 (48.8)			6.9 (3.2)	5.8 (2.7)	5.3 (2.5)	160 (48.8)			5.6 (2.6)	6.0 (2.8)	5.6 (2.6)
170 (51.9)			5.9 (2.7)	4.7 (2.2)	4.1 (1.9)	170 (51.9)			6.1 (2.8)	5 (2.3)	4.4 (2)	170 (51.9)				5.2 (2.4)	4.7 (2.2)
180 (54.9)			5.2 (2.4)	4 (1.9)	3.4 (1.6)	180 (54.9)			5.4 (2.5)	4.3 (2)	3.7 (1.7)	180 (54.9)				4.5 (2.1)	4 (1.9)
190 (58)			4.6 (2.1)	3.4 (1.6)		190 (58)				3.6 (1.7)	3.1 (1.5)	190 (58)				3.8 (1.8)	3.3 (1.5)
200 (61)						200 (61)				3.1 (1.5)		200 (61)					

This material is supplied for reference use only. Operator must refer to in-cab Crane Rating Manual and Operator's Manual to determine allowable crane lifting capacities and assembly and operating procedures.

75 ft (22.86m) Offset Jib Length – 360° Rotation – ABCD+A [80,000+26,500 lb (36 364+12 040kg)] Counterweight [All capacities are listed in kips (mt)]																	
5° Offset						15° Offset					25° Offset						
Load Radius ft (m)	Main Boom Length ft (m)					Load Radius ft (m)	Main Boom Length ft (m)					Load Radius ft (m)	Main Boom Length ft (m)				
	45 (13.8)	105 (32.1)	145 (44.3)	185 (56.5)	205 (62.5)		45 (13.8)	105 (32.1)	145 (44.3)	185 (56.5)	200 (61.0)		45 (13.8)	105 (32.1)	145 (44.3)	185 (56.5)	205 (62.5)
35 (10.7)	18.8 (8.6)					35 (10.7)						35 (10.7)					
40 (12.2)	17.1 (7.8)					40 (12.2)						40 (12.2)					
50 (15.3)	13.3 (6.1)	17.9 (8.2)	18.0 (8.2)			50 (15.3)	10.3 (4.7)					50 (15.3)					
60 (18.3)	10.9 (5)	15.4 (7)	17.2 (7.9)	17.0 (7.8)	16.6 (7.6)	60 (18.3)	8.6 (4)	10.7 (4.9)				60 (18.3)	6.7 (3.1)				
70 (21.4)	9.1 (4.2)	13.1 (6)	15.5 (7.1)	16.4 (7.5)	16.1 (7.4)	70 (21.4)	7.4 (3.4)	9.4 (4.3)	10.4 (4.8)	11.2 (5.1)		70 (21.4)	5.8 (2.7)	6.8 (3.1)			
80 (24.4)	7.8 (3.6)	11.4 (5.2)	13.5 (6.2)	15.5 (7.1)	15.6 (7.1)	80 (24.4)	6.4 (3)	8.4 (3.9)	9.4 (4.3)	10.1 (4.6)	10.5 (4.8)	80 (24.4)	5.2 (2.4)	6.2 (2.9)	6.6 (3)		
90 (27.5)	6.8 (3.1)	10.0 (4.6)	12.0 (5.5)	13.8 (6.3)	14.7 (6.7)	90 (27.5)	5.7 (2.6)	7.6 (3.5)	8.5 (3.9)	9.3 (4.3)	9.6 (4.4)	90 (27.5)	4.6 (2.1)	5.6 (2.6)	6.1 (2.8)	6.4 (3)	
100 (30.5)	6.0 (2.8)	9.0 (4.1)	10.8 (5)	12.5 (5.7)	13.3 (6.1)	100 (30.5)	5.1 (2.4)	6.9 (3.2)	7.8 (3.6)	8.6 (4)	8.9 (4.1)	100 (30.5)	4.2 (2)	5.2 (2.4)	5.7 (2.6)	6.0 (2.8)	
110 (33.6)	5.4 (2.5)	8.1 (3.7)	9.7 (4.5)	11.3 (5.2)	11.3 (5.2)	110 (33.6)	4.7 (2.2)	6.3 (2.9)	7.2 (3.3)	8.0 (3.7)	8.3 (3.8)	110 (33.6)		4.8 (2.2)	5.3 (2.5)	5.7 (2.6)	
120 (36.6)		7.3 (3.4)	8.9 (4.1)	10.1 (4.6)	9.6 (4.4)	120 (36.6)		5.8 (2.7)	6.7 (3.1)	7.4 (3.4)	7.7 (3.5)	120 (36.6)		4.5 (2.1)	5.0 (2.3)	5.3 (2.5)	
130 (39.7)		6.7 (3.1)	8.1 (3.7)	8.7 (4)	8.2 (3.8)	130 (39.7)		5.4 (2.5)	6.2 (2.9)	6.9 (3.2)	7.3 (3.4)	130 (39.7)		4.3 (2)	4.7 (2.2)	5.1 (2.4)	
140 (42.7)		6.2 (2.9)	7.5 (3.5)	7.6 (3.5)	7 (3.2)	140 (42.7)		5.1 (2.4)	5.8 (2.7)	6.5 (3)	6.8 (3.1)	140 (42.7)		4.0 (1.9)	4.5 (2.1)	4.8 (2.2)	
150 (45.8)		5.7 (2.6)	7.0 (3.2)	6.5 (3)	6 (2.8)	150 (45.8)		4.8 (2.2)	5.5 (2.5)	6.1 (2.8)	6.4 (3)	150 (45.8)		3.9 (1.8)	4.2 (2)	4.6 (2.1)	
160 (48.8)		5.4 (2.5)	6.5 (3)	5.6 (2.6)	5.1 (2.4)	160 (48.8)		4.5 (2.1)	5.2 (2.4)	5.8 (2.7)	5.5 (2.5)	160 (48.8)			4.1 (1.9)	4.4 (2)	
170 (51.9)		5.1 (2.4)	6 (2.8)	4.9 (2.3)	4.3 (2)	170 (51.9)			4.9 (2.3)	5.2 (2.4)	4.7 (2.2)	170 (51.9)			3.9 (1.8)	4.2 (2)	
180 (54.9)			5.3 (2.5)	4.2 (2)	3.6 (1.7)	180 (54.9)			4.7 (2.2)	4.5 (2.1)	3.9 (1.8)	180 (54.9)				4.1 (1.9)	
190 (58)			4.7 (2.2)	3.6 (1.7)	3 (1.4)	190 (58)			4.5 (2.1)	3.8 (1.8)	3.3 (1.5)	190 (58)				3.9 (1.8)	
200 (61)			4.2 (2)	3 (1.4)		200 (61)				3.3 (1.5)		200 (61)				3.5 (1.6)	

This material is supplied for reference use only. Operator must refer to in-cab Crane Rating Manual and Operator's Manual to determine allowable crane lifting capacities and assembly and operating procedures.

**Link-Belt Cranes**      Lexington, Kentucky      [www.linkbelt.com](http://www.linkbelt.com)

®Link-Belt is a registered trademark. Copyright 2017. We are constantly improving our products and therefore reserve the right to change designs and specifications.