

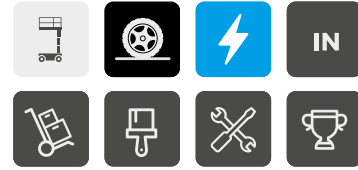

## STAR 20



### GO EVERYWHERE

- > Precision driving and smooth controls
- > Easy access to the platform: dedicated anti-slip step and walkable plinth
- > Agile machine with mobile pothole protection
- > Intuitive control box with battery charge indicator in platform
- > Smart transportability & lifting
- > Platform extension deck (+ 16 in)

### THE BEST VALUE FOR THE MONEY

- > Haulotte Activ'Energy Management takes care of your batteries
- > 4- stage cylinder mast with no chain or cable
- > Minimal maintenance & downtime
- > Electric drive with brushless AC motors
- > Easy access to components
- > Haulotte Activ'Screen (onboard diagnostics)

## VERTICAL MASTS

### TECHNICAL DATA

#### STAR 20

Working height	25 ft 8 in
Platform height	19 ft 8 in
Horizontal outreach	N/A
Lift capacity	441 lb (1 Pers.)
<b>A</b> Length	4 ft 7 in
<b>B</b> Width	2 ft 7 in
<b>C</b> Height - stowed	6 ft 6 in
<b>D</b> Wheelbase	3 ft 6 in
<b>E</b> Ground clearance	2.36 in
Platform size	31 in x 54 in
Platform size with extension	31 in x 71 in
Drive speed	0.5 - 2.8 mph
Turning radius - outside	5 ft 7 in
Tilt alarm	1.5° / 3°
Gradeability	25 %
Driveable at full height up to	19 ft 8 in
Hydraulic tank capacity	1.8 gal
Tires	13 x 5
Batteries	4 x 6 V - 180 Ah (C5)
Weight	2,580 lb

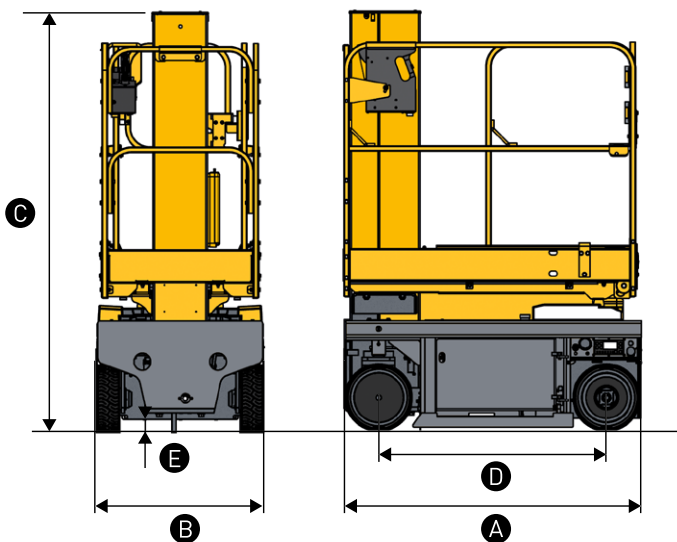

### STANDARD EQUIPMENT

- > Haulotte Activ'Energy Management: Smart CAN charger
- > Haulotte Activ'Screen
- > 24 V electric drive brushless AC motors
- > 2 x 12 V - 105 Ah batteries
- > Battery charge indicator
- > Fork lift pockets
- > Lifting eyes
- > Swing door entry gate with lock
- > Platform extension + 16 in
- > Mobile pothole protection
- > 2 rear steering wheels
- > 2 front driving wheels
- > Non-marking tires
- > Brake release
- > Hourmeter
- > Horn
- > Travel alarm
- > Emergency hand pump
- > Lowering system
- > 2 control stations - in the basket and at ground level
- > Mobile upper control box
- > High speed selector on upper control box
- > Towing hooks

### OPTIONS AND ACCESSORIES

- > Haulotte Activ'Energy Management: automatic or manual battery waterfilling systems
- > Telematics ready
- > Maintenance-free batteries
- > Flashing beacon
- > Power to the platform
- > Tool tray
- > Upper control box cover
- > Ground-fault circuit interrupter 30 mA
- > Hydraulic oil for cold climates
- > Biodegradable oil

