

IC-35-G **Industrial Crane**

The IC-35 is small in size with big crane features. This machine is a customer favorite because of its legendary reliability. It's tight turning radius is perfect for maneuverability in space-constrained work sites.

Capacity

8,000 lbs. (3,620 kg)

Sheave Height

33' 4" (10.2 m)
(with boom extension)

Horizontal Reach

27' 2" (8.28 m)
(with boom extension)

Height

6' 6" (1.98 m)

Width

5' (1.52 m)



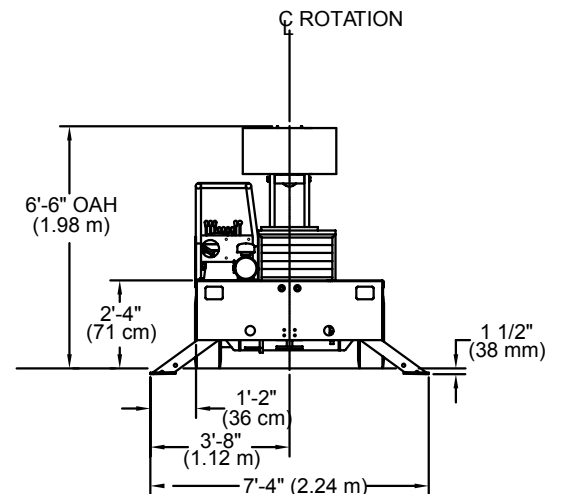
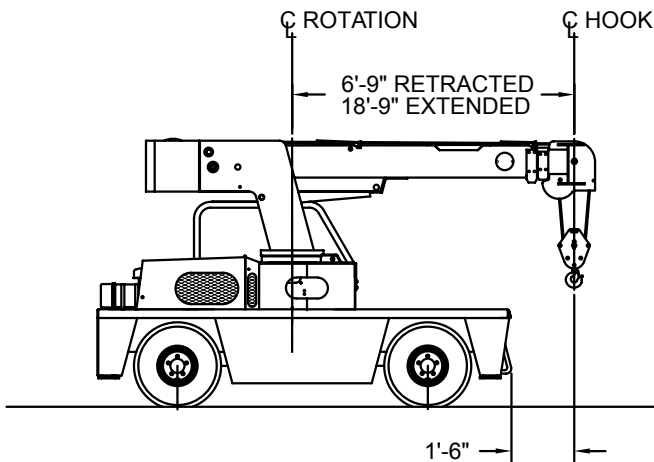
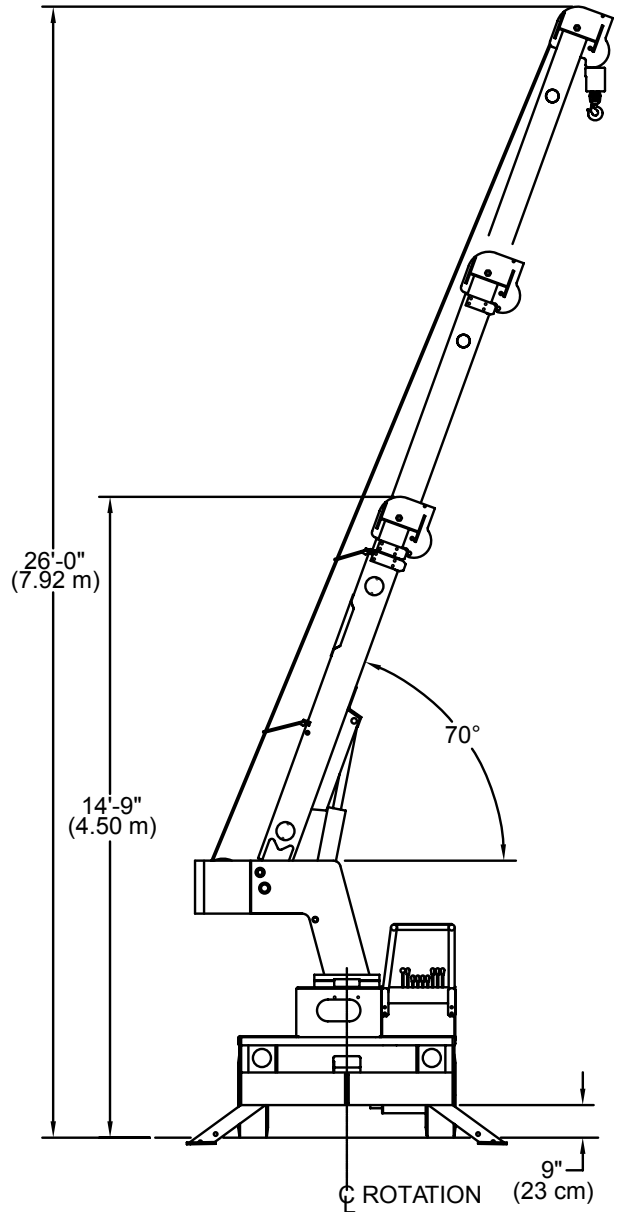
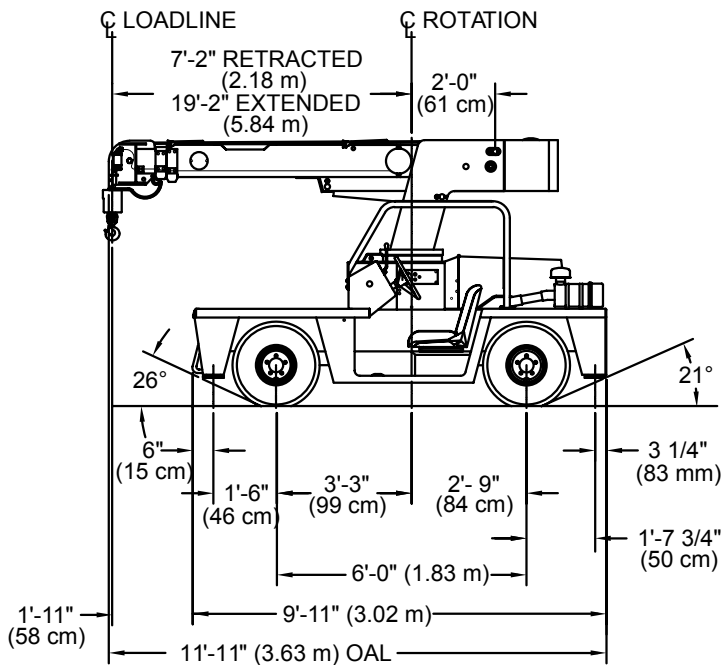
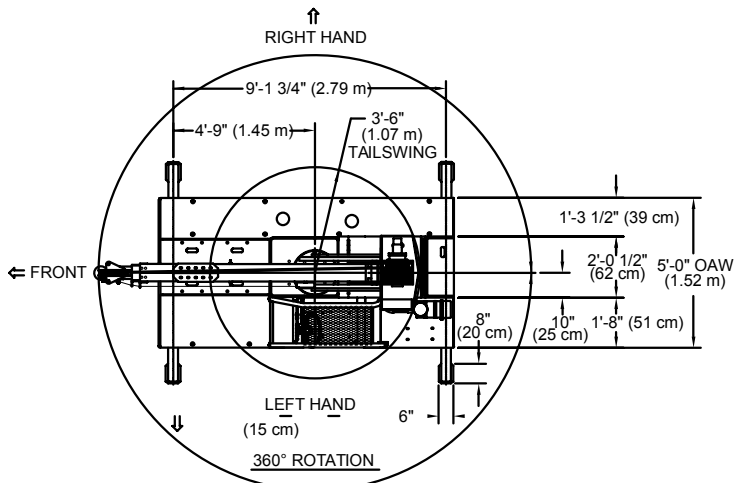

IC-35-G

GENERAL SPECIFICATIONS



GENERAL

	ROTATION	ELEVATION	EXTENSION
Boom Movement	Continuous	0° to 70°	12' (3.66m)
Boom Speeds	1.5 RPM	17 sec.	32 sec.
Weight Total	7,860 lbs. (3,565 kg.)		
Travel Speed	0 to 10 mph (16 km/h)		
Drawbar Pull	2,120 lbs. (960 kg.)		
Gradeability	30%		

ENGINE

Make	Kubota	Kubota
Model	1.6L EFI	1.8L D1803 (T4F)
Type	Dual Fuel	Diesel
Cylinder	4	3
Displacement	1.6L	1.8L
HP @ Gov. Speed	44HP (35kW)	50HP (37kW)
Fuel Tank Capacity	13.5 gal. (51L)	13.5 gal. (51L)

HYDROSTATIC PUMP

Piston type, direct driven from engine crankshaft.
Maximum flow 34 GPM (120 L/min).
Maximum pressure 4,000 psi (275 bar).

AXLES

FRONT
Channel shaped structure houses torque hubs, brakes and hydraulic drive motors. Axle oscillates a total of 1 1/2" (38 mm).
REAR
Fixed rigid to frame.

STEERING

Full hydraulic steering unit controls 2 1/2" (63 mm.) steering cylinder attached to rear axle.

BRAKES

Primary braking from hydrostatic transmission. Foot-actuated disc brake attached to each torque hub for additional braking in some conditions. Parking brake switch locks brakes to hold crane when not being driven.

TIRES

FRONT
7.5 x 10 pneumatic, 16-ply, 145 PSI, (1000 kPa)
REAR
7.5 x 10 pneumatic, 16-ply, 145 PSI, (1000 kPa)

CHASSIS

CARGO DECK
9 sq. ft. (2.7m) of deck area. 6,000 lbs. (2,720 kg) capacity on deck when load is centered over or between axles.

OUTRIGGERS
Four hydraulic outriggers of box-beam construction. Independent controls for each. Hydraulic cylinders are equipped with direct-connected holding valves.

HEADLIGHT & TAILLIGHT GRILLES
Welded steel protective grilles for headlights and taillights.

LIFTING RINGS
Lifting rings at each corner of cargo deck so sling can be attached for lifting crane.

FRONT PULLING EYE
Mounted on front bumper.

OPERATOR COMPARTMENT

Provides one-position access to all chassis & crane functions. Includes adjustable operator's seat, retracting seat belts, fire extinguisher & bubble level.

ELECTRICAL (12-VOLT SYSTEM)

LIGHTING PACKAGE
One pair headlights and taillight.

DISPLAY
Fuel, voltmeter, oil pressure, and water temperature gauges, hydraulic oil temperature gauge and hourmeter.

BACK-UP ALARM
Provides pulsating sound from 97dB alarm when transmission is in reverse.

OUTRIGGER ALARM SYSTEM
112 dB alternating two-tone alarm is activated when "outrigger down" controls are operated.

HYDRAULIC

TANDEM PUMP mounted to rear of hydrostatic piston pump. Delivers 6 GPM (23 L/min) at 2,600 PSI (179 bar) for boom circuits and 17 GPM (64 L/min) at 2,500 PSI (155 bar) for hoist circuit. System protected by relief valves. Hydraulic oil reservoir has 14 gallon (53L) capacity.

BOOM ASSEMBLY

THREE-SECTION BOOM ASSEMBLY
equipped with bearing pads, double-acting hydraulic cylinders extends boom. The primary extension cylinder and the double-acting boom elevation cylinder are equipped with direct connected holding valves. Boom angle indicator on side of boom.

BOOM ROTATION
Heavy-duty ball bearing rotation gear with external teeth. Rotation is powered by hydraulic motor & worm gear drive.

BOOM HOIST
Turret mounted planetary gear hoist hydraulically powered with a bare drum line pull of 5,000 lbs. (2,268 kg) & a line speed of 86 FPM (26 m). Hoist includes 85 ft. (26 m) of 3/8 in. (9.5 m) wire rope, downhaul weight, swivel hook and sheave block for 2-part line.

ANTI-TWO-BLOCK DEVICE
Prevents damage to hoist rope and/or crane components from pulling load hook against tip.

RATED CAPACITY LIMITER
Warns operator of impending overload with audible & visual signals. Prevents overload by stopping boom functions that cause overloads.

CONSULT THE IC-35-G ENGINEERING SPEC FOR ADDITIONAL INFORMATION.

Main Features

RATED CAPACITY LIMITER
Standard

CAPACITY ON OUTRIGGERS
8,000 lbs. (3,620 kg)

PICK AND CARRY CAPACITY
up to 6,700 lbs. (3,040 kg)

HEIGHT
6' 6" (1.98 m)

WIDTH
5' (1.52 m)

BOOM ROTATION
360° Continuous

SHEAVE HEIGHT
up to 33' 4" (10.2 m)

HORIZONTAL REACH
up to 27' 2" (8.28 m)

TIGHT TURNING RADIUS

REAR WHEEL STEER
Standard

FRONT WHEEL DRIVE
Standard

**FULLY HYDRAULIC CONTROLS FOR
SMOOTH, PRECISE OPERATIONS**

**INDEPENDENT OUTRIGGER
CONTROLS**

DUAL FUEL OR DIESEL AVAILABLE

Options

TIRE

Solid Rubber Tires

For applications where hazardous ground conditions exist.

Solid Rubber Tires - Non Marking

Foam Filling of Tires

Spare Tire & Wheel - Pneumatic

Spare Tire & Wheel - Solid Rubber

Spare Tire & Wheel - Solid Rubber, Non Marking

Foam Filling of Spare Tires

CHASSIS OPTIONS

Auxiliary Winch

Mounted behind the front bumper, hydraulically driven with control in operator's console - 3,000 lbs (1,360 kg) @ 20 FPM (6m/min).

Pintle Hook - Rear

Holland "T-60-A" pintle hook mounted on rear of frame. 5-ton capacity.

Lifting Sling

Three leg lift sling to attach to Lifting Rings.

Rearview Mirrors

One mounted on right-hand deck stake and one mounted on left-hand deck stake. Pivots out of the way for obstacles.

OPERATOR COMPARTMENT

All Weather Cab

Rigid-mounted canopy section and removable hinged door with safety glass. Cab door adds 4 in. (102 mm) to crane on operator's side. Includes heater, electric windshield wiper, one sliding glass window in the door, & one fold out window in rear. Defroster fan & dome light included.

Cab Heater Only

Heater with two-speed fan for units without All Weather Cab.

Operator Guard

Tubular steel weldment with heavy expanded steel mesh top section for units without All Weather Cabs.

Floor Mat

Vinyl mat with foam backing.

ELECTRICAL

Strobe Lights

Yellow strobe light mounted on each side of turret weight box.

Boom Work Lights

One work light mounted to boom to light boom tip and one work light mounted to turret to light ground under boom tip. Includes switch in operator's compartment.

RCL Light Bar

3 color light bar for external indication of load status

EXTRA LONG WIRE ROPE

140 ft. (42.6m), boom stowable

BOOM ATTACHMENTS

Boom Extension

8 foot (2.4 m), boom stowable.

Boom Extension, Offset

8 foot (2.4 m), boom stowable. Boom extension is offsettable to 3 different positions; 0° (in line), 15 degree and 30° offset.

Searcher Hook - Nose Mount

2,000 lb (907kg) capacity. Swivel hook with spring latch hangs from support structure projecting outward from boom tip.

Broderson Cranes are manufactured to ISO 9001:2015 certified standards and have a market leading reputation for quality and reliability. Broderson Cranes are engineered for operating efficiency and are easy to operate and maintain.

An extensive network of full-service dealers offer parts and service support by factory-trained technicians.

For additional options or special equipment not listed, please consult your dealer salesperson or contact Broderson Manufacturing Corp.

BRODERSON[®]
Manufacturing Corp.
14741 West 106th Street
Lenexa, KS 66215 USA

(913) 888-0606
www.BMCcranes.com

Dimensions and values shown
are for reference purposes
only. Specifications subject
to change.



Load Chart US Standard

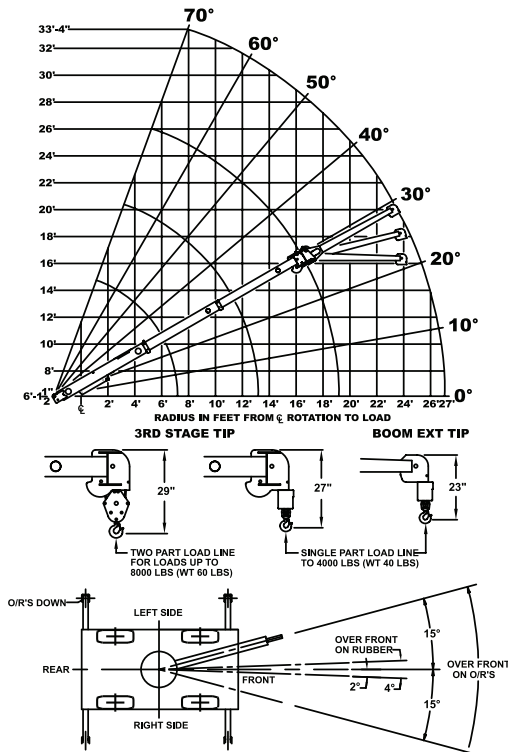

Load radius is the horizontal distance from the center of rotation of the unloaded crane to the vertical load line with the load applied.

Load hooks, downhaul weights, hook blocks, and other load handling devices except hoist rope shall be considered part of the load.

Pick and carry with the shortest practical boom, centered over the front. Operate with the boom as low as possible, with the load close to the ground. Pick and carry capacities are for smooth, level paved surface.

Deck load 6000 lbs max, centered between wheels, with no boom load. Deck loads must be centered behind the front axle. Speed must be less than 2 mph. Maximum travel 200 ft. In 30 minutes.

CAPACITIES APPLY TO OPERATION ON FIRM LEVEL SURFACE									
LOAD RADIUS FEET	MAIN BOOM OR EXTENSION CAPACITIES IN POUNDS								
	360° ROTATION			OVER FRONT					
	ON RUBBER	ON OUTRIGGERS	ON RUBBER	ON OUTRIGGERS	ON RUBBER	ON OUTRIGGERS			
4	5000	8000	6700	8000					
5	4000	6800	5800	6800					
6	2850	5850	5100	5850					
8	1800	4150	3500	4150					
10	1250	3200	2350	3400					
12	900	2350	1750	2850					
14	700	1850	1350	2450					
16	600	1500	1100	2150					
18	500	1250	950	1950					
19	450	1150	900	1850					
20	400	1100	850	1600					
22	300	900	700	1450					
24	250	800	600	1300					
26	200	700	500	1150					
27	150	650	450	1100					
8' BOOM EXTENSION	BOOM EXTENSION - 8-FOOT BOOM EXTENSION - STRAIGHT OR OFFSET								
	MAIN BOOM ANGLE								
	ANGLE	0°	10°	20°	30°	40°	50°	60°	70°
	+* 0°	1100	1200	1300	1450	1600	1850	2300	3500
* 15°	—	—	1100	1250	1350	1500	1700	2050	
* 30°	—	—	—	1100	1200	1300	1450	1600	

+ USE 0° FOR STRAIGHT BOOM EXTENSION * USE 0°, 15° or 30° FOR OFFSET BOOM EXTENSION

The booms on this unit are all steel and have no line voltage rating.

The load hoist line on this unit must be 3/8" dia. 6X36 EIP IWRC wire rope with a minimum breaking strength of 15,100 lbs.

OPERATION

1. Read and understand owners manual before operating this crane.
2. Check level of engine oil and hydraulic oil daily.
3. Check unit for visible defects daily.
4. Extend outriggers fully if possible. If not, use "on rubber" chart.
5. Avoid quick starts and stops when operating or driving crane.

TIRE PRESSURE: 145 PSI FOR 7.50 X 10-16PL. MAXIMUM HYDRAULIC PRESSURE 2600 PSI.

EXCEEDING CAPACITY RATINGS OR APPLYING SIDE LOADS THE THE BOOM OR BOOM EXTENSION IS MISUSE, HAZARDOUS, AND VOIDS WARRANTY.

CAUTION: BOOM EXTENSION LOADS MUST NOT EXCEED MAIN BOOM CAPACITY. BOOM EXTENSION MAY ONLY CARRY LOADS WITH OUTRIGGERS DOWN. BOOM EXTENSION DEDUCT: 100 LBS. WHEN STOWED ON BASE BOOM. DO NOT PICK AND CARRY WITH LOADS ON BOOM EXTENSION. ENSURE ANTI-TWO-BLOCK SWITCH IS FUNCTIONAL AFTER DEPLOYING OR STOWING BOOM EXTENSION.

CAPACITIES ON OUTRIGGERS OUT & DOWN ARE 85% OF TIPPING LOADS. CAPACITIES ON RUBBER ARE 75% OF TIPPING LOADS. CAPACITIES BELOW BOLD LINE ARE LIMITED BY TIPPING. OTHER CAPACITIES ARE LIMITED BY STRUCTURAL OR HYDRAULIC CAPABILITY.

Load Chart Metric

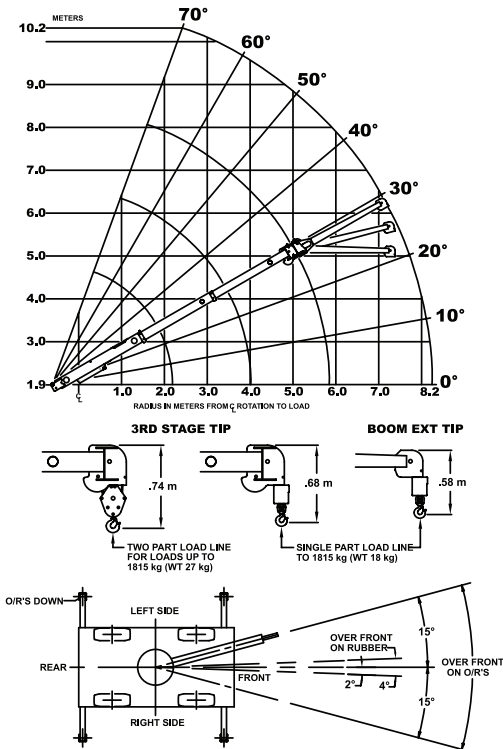

Load radius is the horizontal distance from the center of rotation of the unloaded crane to the vertical load line with the load applied.

Load hooks, downhaul weights, hook blocks, and other load handling devices except hoist rope shall be considered part of the load.

Pick and carry with the shortest practical boom, centered over the front. Operate with the boom as low as possible, with the load close to the ground. Pick and carry capacities are for smooth, level paved surface.

Deck load 2720 kg max, centered between wheels, with no boom load. Deck loads must be centered behind the front axle. Speed must be less than 3 km/h. Maximum travel 60m in 30 minutes.

CAPACITIES APPLY TO OPERATION ON FIRM LEVEL SURFACE									
LOAD RADIUS METERS	MAIN BOOM OR EXTENSION CAPACITIES IN KILOGRAMS								
	360° ROTATION		OVER FRONT						
	ON RUBBER	ON OUTRIGGERS	ON RUBBER	ON OUTRIGGERS					
MAIN BOOM	1.2	2260	3620	3040	3630				
	1.5	1850	3120	2650	3120				
	2.0	1090	2420	2120	2420				
	2.5	780	1830	1520	1830				
	3.0	580	1480	1090	1560				
	3.5	440	1160	850	1350				
	4.0	350	920	680	1180				
	4.5	300	770	560	1050				
	5.0	260	650	480	950				
	5.8	200	520	410	840				
2.44 m BOOM EXTENSION	6.0	190	500	390	750				
	6.5	150	430	340	680				
	7.0	120	380	290	620				
	7.5	100	350	250	570				
	8.2	70	290	200	500				
	BOOM EXTENSION	2.44 m BOOM EXTENSION - STRAIGHT OR OFFSET							
		MAIN BOOM ANGLE							
	ANGLE	0°	10°	20°	30°	40°	50°	60°	70°
	+* 0°	500	540	590	660	720	840	1040	1590
	* 15°	—	—	500	560	610	680	770	930
* 30°	—	—	—	500	540	590	660	720	

+ USE 0° FOR STRAIGHT BOOM EXTENSION * USE 0°, 15° or 30° FOR OFFSET BOOM EXTENSION

The booms on this unit are all steel and have no line voltage rating.

The load hoist line on this unit must be 10mm. 6X36 EIP IWRC wire rope with a minimum breaking strength of 67 kN.

OPERATION

1. Read and understand owners manual before operating this crane.
2. Check level of engine oil and hydraulic oil daily.
3. Check unit for visible defects daily.
4. Extend outriggers fully if possible. If not, use "on rubber" chart.
5. Avoid quick starts and stops when operating or driving crane.

TIRE PRESSURE: 1000 kPa FOR 7.50 X 10-16PL. MAXIMUM HYDRAULIC PRESSURE 180 BAR.

EXCEEDING CAPACITY RATINGS OR APPLYING SIDE LOADS TO THE BOOM OR BOOM EXTENSION IS MISUSE, HAZARDOUS, AND VOIDS WARRANTY.

CAUTION: BOOM EXTENSION LOADS MUST NOT EXCEED MAIN BOOM CAPACITY. BOOM EXTENSION MAY ONLY CARRY LOADS WITH OUTRIGGERS DOWN. BOOM EXTENSION DEDUCT: 45 KG. WHEN STOWED ON BASE BOOM. DO NOT PICK AND CARRY WITH LOADS ON BOOM EXTENSION. ENSURE ANTI-TWO-BLOCK SWITCH IS FUNCTIONAL AFTER DEPLOYING OR STOWING BOOM EXTENSION.

CAPACITIES ON OUTRIGGERS OUT & DOWN ARE 85% OF TIPPING LOADS. CAPACITIES ON RUBBER ARE 75% OF TIPPING LOADS. CAPACITIES BELOW BOLD LINE ARE LIMITED BY TIPPING. OTHER CAPACITIES ARE LIMITED BY STRUCTURAL OR HYDRAULIC CAPABILITY.