

Technical sheet :

MSI 30 3B - FT4



		Technical characteristics		Imperial
1.1		Manufacturer		Manitou
1.2		Model Name		MSI 30 3B - FT4
1.3		Power source		Diesel
1.4		Operator type		Seated
1.5		Max. capacity	Q	6613 lbs
1.6		Load centre of gravity	c	1 ft 8 in
1.8		Load distance, centre of drive axle to fork	x	2 ft 1 in
1.9		Wheelbase	y	5 ft 11 in
		Weight		
2.1		Service weight		10372 lbs
2.2		Weight on front axle (laden) / rear axle (laden)		14947 lbs / 2039 lbs
2.3		Weight on front axle (Unladen) / rear axle (Unladen)		4188 lbs / 6183 lbs
		Wheels		
3.1		Tyres type		Pneumatic
3.2		Dimensions of front wheels		275/70 R22,5
3.3		Dimensions of rear wheels		7.00x12 14PR
3.5		Number of front wheels / rear wheels		2 / 2
3.5.2		Number of drive wheels		2
3.6		Front wheel gauge	b10	3 ft 5 in
3.7		Rear wheel gauge	b11	3 ft 7 in
		Dimensions		
4.1		Tilt of Mast Forward (deg) / Backward (deg)	α / β	10 / 12
4.8		Seat height/stand height	h7	3 ft 4 in
4.12		Height of towing bar (coupling height)	h10	1 ft
4.19		Overall length	l1	13 ft 5 in
4.20		Length to face of forks	l2	9 ft 9 in
4.21		Overall width	b1	4 ft 4 in
4.21		Overall width - Single wheels	b1	15 ft
4.22		Forks section / width / length	s / e / l	2 in x 4 in / 3 ft 7 in
4.23		Fork carriage ISO 2328 (class/form) A/B		3A
4.24		Fork carriage width	b3	4 ft 2 in
4.31		Ground clearance below mast	m1	11 in
4.32		Ground clearance at centre of wheelbase	m2	10 in
4.34		Aisle width for 800 x 1200 pallet lengthways	Ast	15 ft 3 in
4.36		Internal turning radius (over tyres)	b13	6 in
4.35		Turning radius	Wa	8 ft 8 in
		Performances		
5.1		Travel speed (laden / unladen)		12.4 mph / 12.4 mph
5.2		Lifting speed (laden / unladen)		1.31 ft/s / 1.64 ft/s

		Performances	
5.3	Lowering speed (laden / unladen)		1.64 ft/s / 1.31 ft/s
5.5	Drawbar pull (Laden / Unladen)		2460 daN / 1260 daN
5.7	Gradeability (laden / unladen)		24 % / 29 %
5.10	Service brake		Hydraulic
	Engine		
7.1	Engine brand / model		Kubota / V2403 CR TE4
7.2	Engine power according to ISO 1585		48.6 kW
7.3	Rated speed		2700 rpm
7.4	Number of cylinders / Capacity of cylinders		4 - 148.53 in ³
		Miscellaneous	
8.1	Type of drive control		Hydraulic
8.2	Working hydraulic pressure for attachments		12 PSI
8.3	Oil flow rate for attachments		77 l/min

Dimensional drawing

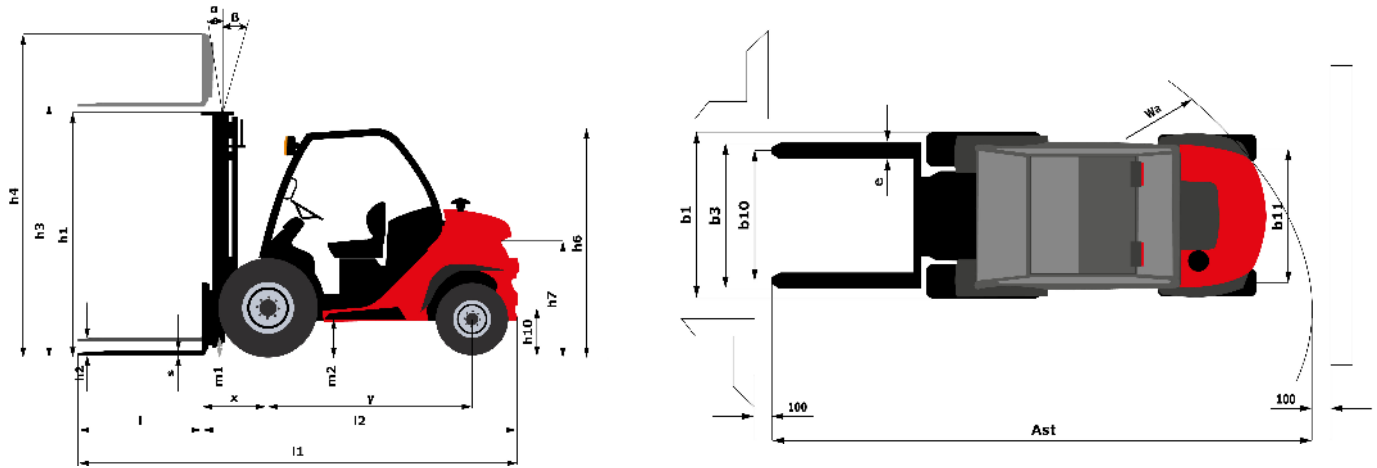

Characteristics of masts and residual capacities

		FVD 30	FVD 33	FVD 35	FVD 37	FVD 40	FVD 45	FVD 50	FVD 55	FVD 60
h2 - Free lift	in	0.005"	0.005"	0.005"	0.005"	0.005"	0.005"	0.005"	0.005"	0.005"
h1 - Height mast lowered *	in	7' 1"	7' 7"	7' 10"	8' 5"	9'	9' 10"	10' 8"	11' 6"	12' 5"
h4 - Height mast extended *	in	12' 9"	13' 9"	14' 5"	15' 1"	16' 1"	17' 8"	19' 3"	21'	22' 7"
α / β - Mast inclination (front / rear)	°	10 / 12	10 / 12	10 / 12	10 / 12	10 / 12	10 / 12	10 / 12	10 / 12	10 / 12
Residual capacity at max height	lbs	6614	6614	6614	6614	6614	5732	5291	4189	3307

Free Lift Triplex		FLT 37	FLT 40	FLT 43	FLT 47	FLT 50	FLT 55	FLT 60	FLT 65	FLT 70
h2 - Free lift	in	4' 3"	4' 7"	5' 1"	5' 5"	5' 11"	6' 7"	7' 4"	8' 2"	9'
h1 - Height mast lowered *	in	6' 9"	7' 1"	7' 7"	7' 10"	8' 5"	9'	9' 10"	10' 8"	11' 6"
h3 - Lifting Height	in	12' 2"	13' 1"	14' 1"	15' 5"	16' 5"	18' 1"	19' 8"	21' 4"	23'
h4 - Height mast extended *	in	14' 9"	15' 9"	16' 9"	18' 1"	19'	20' 8"	22' 4"	23' 11"	25' 7"
α / β - Mast inclination (front / rear)	°	10 / 12	10 / 12	10 / 12	10 / 12	10 / 12	10 / 12	10 / 12	10 / 12	10 / 12
Residual capacity at max height	lbs	6614	6614	6173	5732	5291	4189	3307		



Siège Social

430 rue de l'Aubinière - 44150 Ancenis Cedex - France

Tel: +33(0)2 40 09 10 11 - Fax: +33 (0)2 40 09 10 97

www.manitou.com



This brochure describes versions and configuration options for Manitou products which may be fitted with different equipment. The equipment described in this brochure may be standard, optional or not available depending on version. Manitou reserves the right to change the specifications shown and described at any time and without prior warning. The manufacturer is not liable for the specifications given. For more information, contact your Manitou dealer. Non-contractual document. Product descriptions may differ from actual products. List of specifications is not comprehensive. The logos and visual identity of the company are the property of Manitou and may not be used without authorisation. All rights reserved. The photos and diagrams contained in this brochure are provided for information only.

MANITOU BF SA - Limited company with board of directors - Share capital: 39,668,399 euros - 857 802 508 RCS Nantes