



The Lifting Professionals

Bolingbrook, IL  
(630) 972-9199

South Holland, IL  
(219) 972-9199

Click Here to Request a Quote



# Shuttlelift CD3339

## Quick Reference

Capacity: 8,5 t (9 USt)

Boom: 4,2 m - 10,0 m (13 ft 10 in - 32 ft 10 in) main boom

Max jib: 3,6 m (12 ft)

Max tip height: 11,6 m (38 ft 2 in)

## FEATURES

- 8,1 t (9 USt) three-section boom
- 3,6 m (12 ft) fixed extension
- 63,4 kW (85 bhp) Cummins diesel engine or 59,6 kW (80 bhp) GM EFI dual fuel engine
- Exclusive pivoting boom nose
- Two-wheel, four-wheel and crab steering

## Working range

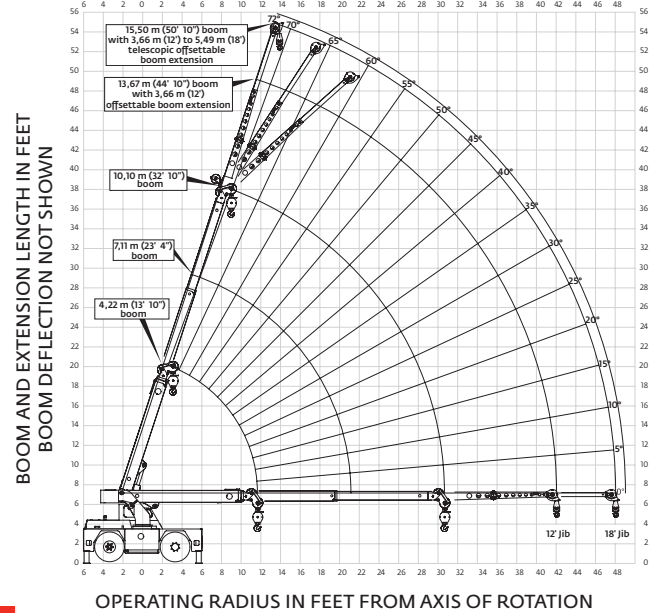

## Load chart

RADIUS (ft)	ON OUTRIGGERS (lb)				ON RUBBER (lb)	
	360°		360°		F/R	360°
	BOOM RETRACTED	BOOM EXTENDED	BOOM RETRACTED	BOOM EXTENDED	ANY BOOM	ANY BOOM
5.0	18,000	14,700	18,000	14,700	11,500	9400
6.0	15,700	14,400	15,000	14,400	10,000	7500
8.0	12,200	12,200	11,400	11,400	8100	5040
10.0	10,200	10,200	9100	9100	5480	3530
12.0	8400	8400	7600	7600	3920	2590
14.0	-	7200	-	6500	3040	1970
16.0	-	6200	-	5310	2420	1560
18.0	-	5400	-	4340	1970	1250
20.0	-	4830	-	3610	1640	1020
22.0	-	4000	-	3030	1370	850
24.0	-	3480	-	2590	1160	710
26.0	-	3020	-	2250	990	590
28.0	-	2680	-	2010	830	490
31.0	-	2270	-	1740	650	360
34.0	-	1960	-	1500	510	250
36.0	-	1770	-	1350	430	180
38.0	-	1590	-	1200	350	130
40.0	-	1420	-	1050	280	80
42.0	-	1270	-	930	210	60
44.0	-	1200	-	880	190	40
46.0	-	1160	-	820	170	20
48.0	-	1110	-	760	140	0

MAIN BOOM ANGLE (deg)	JIB STRUCTURAL CAPACITIES (lb)					
	12 ft JIB			18 ft JIB		
	0° OFFSET	15° OFFSET	30° OFFSET	0° OFFSET	15° OFFSET	30° OFFSET
72	7500	5100	3500	4000	3300	2300
70	7000	4800	3400	3750	3100	2200
65	5700	4100	3100	3200	2700	2000
60	4500	3500	2800	2800	2400	1850
55	3500	3000	2550	2450	2150	1700
50	2800	2500	2300	2150	1950	1600
45	2300	2200	2000	1900	1750	1500
40	2000	1900	1800	1700	1600	1400
35	1775	1675	1600	1525	1450	1350
30	1600	1500	1400	1400	1300	1200
25	1450	1400	-	1275	1200	-
20	1350	1350	-	1175	1125	-
15	1300	1300	-	1100	1100	-
10	1275	-	-	1050	-	-
5	1225	-	-	1025	-	-
0	1200	-	-	1000	-	-

NOTES:  
JIB CAPACITY IS LIMITED BY BOTH STRUCTURAL CAPACITY CHART AND MAIN CAPACITY CHART.

SHADED AREAS ARE GOVERNED BY STRUCTURAL STRENGTH. DO NOT RELY ON TIPPING.

OPERATION OF THIS EQUIPMENT IN EXCESS OF RATING CHARTS AND DISREGARD OF INSTRUCTIONS IS DANGEROUS AND VOIDS WARRANTY.

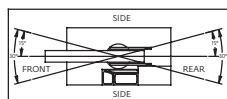

REDUCTION CHART		
	FROM MAIN BOOM RATINGS	FROM MAIN JIB RATINGS
MAIN BLOCK	140 lb	N/A
HOOK & BALL	100 lb	100 lb
JIB, STOWED	0 lb	N/A
JIB, DEPLOYED	450 lb	0 lb

RIGGING CHART	
1-PART	2-PART
0 - 10,000 lb	0 - 18,000 lb

WIRE ROPE: 9/16 in diameter  
Min. breaking strength 35,000 lb

- The rated loads are the maximum lifting capacities as determined by operating radius only. Any combination of boom lengths and angles may be used to obtain operating radius. The operating radius is the horizontal distance from a projection of the axis of rotation to the supporting surface, before loading, to the center of vertical hoist line or tackle with load applied.
- The rated loads shown on outriggers do not exceed 85% of actual tipping. The rated loads shown on rubber do not exceed 75% of actual tipping. These ratings are based on freely suspended loads with the crane leveled, standing on a firm, uniform, supporting surface. Practical working loads depend on supporting surface, operating radius, and other factors affecting stability. Hazardous surroundings, climatic conditions, experience of personnel, and proper training must all be taken into account by the operator.
- The weights of all load handling devices such as hooks, hook blocks, slings, etc., except the hoist rope, shall be considered as part of the load. See reduction chart.
- Ratings on outriggers are with outriggers fully extended.
- Ratings on rubber depend on tire capacity, condition of tires and proper inflation pressure (100 psi). Loads on rubber may be transported at a maximum speed of 2.5 mph on a smooth, hard level surface with boom retracted to the shortest length possible and centered over front.
- For operating radius not shown, use load rating of next larger radius.
- The maximum combined total boom and deck load is 12,000 lb. The maximum deck load only is 14,000 lb.
- Do not induce any external side loads to boom or jib.

1303154

## Dimensions

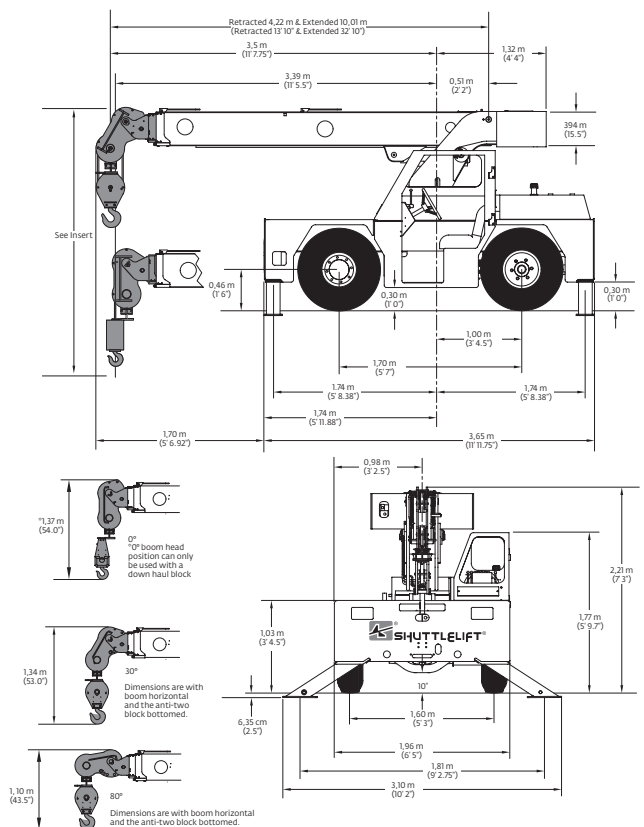

## SUPERSTRUCTURE

### Boom

4,2 m – 10,0 m (13 ft 10 in – 32 ft 10 in) three-section full power boom.

Maximum tip height: 11,6 m (38 ft 2 in)

### \*Boom extension

3,6 m (12 ft) offsettable extension  
3,6 m - 5,4 m (12 ft-18 ft) telescopic offsettable extension

### Boom nose

Single sheave, three-position (0°, +30°, +80°) pivoting boom nose for minimizing head space requirements. Lowers head height. 0,26 m (10.5 in) when nose is pivoted fully forward.

### Boom elevation

Single double acting hydraulic cylinder with integral holding valve. Elevation: 0° to 72°

### Anti-Two block system

Standard anti-two block device, when activated, provides an audible warning to the crane operator and disengages all crane functions when movement can cause two-blocking.

### Load indicator (LSI)

A simple, effective, and easy to use load indicating system used in conjunction with the anti-two block system to assist the operator in efficient operation of the unit within the limits of the load chart. The display panel displays the hook load and warns the operator when a preset load capacity is exceeded. The warning is by a flashing light on the display panel. In conjunction with the load display panel (receiver), there is a wireless transmitter and load sensing pin attached to the boom head that transmits the hook load to the display panel.

(wireless system)

### \*Rated Capacity Limiter (RCL)

Similar to the Load Indicator, but stops the telescope out and boom lift down function when a load limit is exceeded. Uses a similar display panel with the addition of displaying boom angle and boom length read outs on the panel.

(wireless system)

### \*Load Moment Indicator

Digital display of boom angle, boom length, boom radius, capacity, and allows for operator in-put to set the limits based on load chart. Displays color coded light bar and audible alarm with function cutout if load exceeds entered parameters.

(hardwired system)

### Swing

Ball bearing swing circle with 360° continuous rotation.

Hydraulic driven worm gear and pinion.

Maximum speed: 2.05 rpm

### Hydraulic system

Variable displacement piston pump and piggyback gear pump.

Combined flow: 107,9Lpm (28.5 gpm)

Maximum system operating pressure: 3600 psi

Six section valve bank chassis mounted; operated via dash mounted, pilot pressure hydraulic joysticks.

Return line filter with full flow by-pass protection and service indicator.

89 L (23.5 gal) hydraulic reservoir with sight level gauge and steel side plating to guard against side impact damage.

### Hoist

Piston motor drive with spring applied/hydraulic released brake.

#### Drum Diameter:

0,27 m (10.63 in)

#### Maximum Single Line Pull:

6350 kg (14,000 lb)

#### Maximum Single Line Speed:

36,6 m/min (120 fpm)

#### Maximum Permissible Single Line Pull:

4536 kg (10,000 lb) (14,0mm [9/16 inch] EEIPS)

#### Rope Length :

36,6 m (120 ft)

## CARRIER

### Frame

High strength alloy steel constructed with integral outrigger housings; front and rear lifting, towing, and tie-down lugs. 42 ft.<sup>2</sup> carrydeck size with 6350 kg (14,000 lb) carrying capacity. Deck coated with anti-skid treatment.

### Outriggers

Front and rear oblique type beams at all four corners with integral holding valves. Outrigger pads form an integral part of the beam.

Padsize: 18 cm x 20 cm (7.4 in x 7.8 in)

### Outrigger controls

Lever controls located on dash panel which operate the beams in pairs from side to side.

### Standard engine (Tier III)

Cummins QSB 3.3 L turbo-charged diesel rated at 63,4 kW (85 bhp) at 2600 rpm. Supplied with 110 V engine block heater and air intake grid heater.

### \*Optional engine

G.M. 3.0 L EFI dual fuel (gasoline / L.P.) rated at 59,6 kW (80 bhp) at 2600 rpm.

### Operator's control station

Frame mounted, open air style control station with cab shell. Includes all crane functions, driving controls, and overhead safety glass. Other standard equipment include a durable weather resistant seat with seat belt, hourmeter, sight level bubble, and fire extinguisher. The dash panel includes engine oil pressure gauge, engine water temperature gauge, fuel gauge, transmission low oil and high temperature warning lights, low battery warning light, and brake system low pressure warning light. The LSI (load indicator) receiver is mounted to the top of the dash and provides warning for A2B and exceeded load capacity.

### \*Operator's control station enclosed

Includes the standard cab shell with the addition of front and rear glass and glass on the right side. Hinged full door with sliding glass.

Front windshield wiper, heater and defroster is included.

### Fuel tank capacity

70 L (18.5 gallon) all steel construction with steel side plate to guard against side impact.

### Electrical system

One 12V maintenance free battery, 820CCA @ 0°.

Jump start connections  
63 amp alternator.

### Drive

4 x 2 – Front axle drive with planetary hubs and limited slip Differential.

### Steer

Two-wheel, four-wheel with crab steer

Outside turning radius:

Two w/s: 4,47 m (14 ft 8 in)

Four w/s: 3,10 m (10 ft 2 in)

### Transmission

Synchromesh -four- speeds forward and reverse with stalk mounted forward/reverse selector.

### Axles

**Front:** Planetary drive/steer with internal multi-wet-disc brakes and limited slip differential.

**Rear:** Fabricated non-drive steer with disc brakes

### Tires

10.00 x 15 16PR pneumatic

### Brakes

Hydraulic actuated internal wet-disc service brakes acting on all four wheels. A dash mounted toggle switch activates the dry disc parking brake on the transmission output yoke with a dash warning light.

### Suspension

**Front:** Rigid mounted to frame.

**Rear:** Rigid mounted to frame

### Lights

Recessed mounted, includes head, tail, rear work, stop, and turn signals.

### Maximum speed

35,6 km/h (22 mph)

### Gradeability (theoretical)

57%....no load

31%.... 5443 kg (12,000 lb) load

### Gross vehicle weight

7734 kg (17,050 lb)

### Miscellaneous standard equipment

Single sheave, "Quick Reeve" style hookblock 8,1 t (9US t); back up alarm

*\*Denotes optional equipment.*