

MULTI-LOADER

CRAWLER CARRIER



PATENT PENDING

3.0 FX



ALMACRAWLER

MULTI LOADER 3.0 FX

The ML 3.0 FX is a powerful and versatile flatbed tracked carrier which can be used in various heavy-duty applications both indoors and outdoors. It has class-leading electric drive with two super quiet AC electric motors 5.3 kW each (rated IP 67), can be fitted with AGM or Lithium batteries and features three power management configurations:

**FULLY
ELECTRIC
DRIVE**

ECO 0.7mi/h
STD 1.1mi/h
POW 2.6mi/h



Easily extract the battery pack and eliminate downtime. The battery pack is equipped with its own inside charger directly.

Battery Autonomy	Load			MAX Speed
	0 lbs	3307 lbs	6614 lbs	
ECO	~4374 yd	~3828 yd	~3281 yd	0.7 mi/h
STD	~4046 yd	~3390 yd	~2734 yd	1.1 mi/h
POW	~3718 yd	~2953 yd	~2187 yd	2.6 mi/h

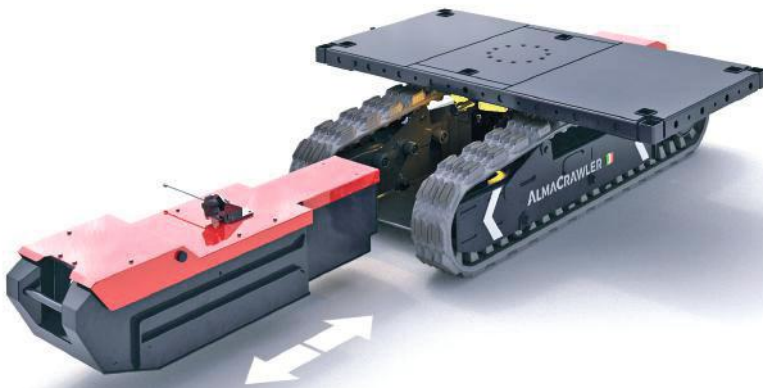

**FULLY REMOVABLE
BATTERY PACK**

**EXTENDABLE
TELESCOPIC
SUPPORT BEAMS**

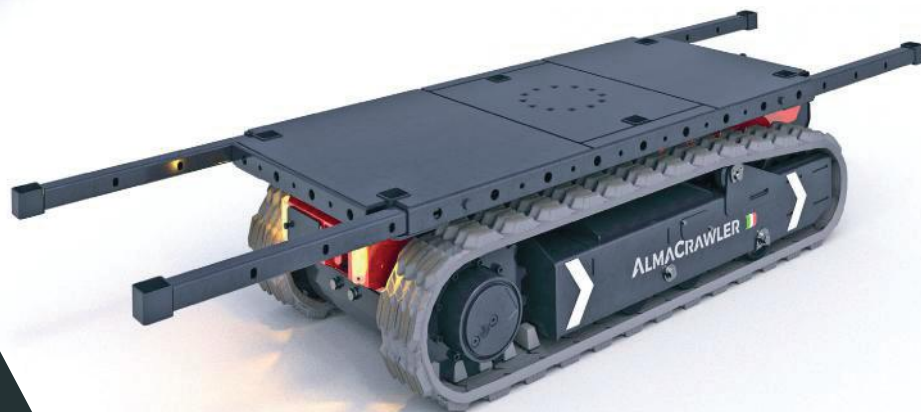

Four support beams on each angle provide added support for extra-large loads. Can be positioned into place manually extending the platform either longitudinally or laterally.

Technical data

	ELC	LTH
Max Capacity	6614 lbs (up to 25°)	
Max Capacity at max gradient	5512 lbs	
Max longitudinal gradient	45°	
Max laterall gradient	30°	
Width	2.59 ft	
Length	5.81 ft	
Track length	4.3 ft	
Track width	0.7 ft	
Ground clearance	2.52 in	
Platform ground height	1.77 ft	
Max speed	2.6 mi/h	
Swivel platform	Standard	
Power of electric motors	10.6 kW	
Voltage	48 V	
Battery capacity & Type (100Ah)	AGM	Lithium
Charger Input & Time (110–230 V)	7h - 13A	4h – 20 A
Ingress Protection IP	IP67	
Controller	Remote radio control	
Gross weight	1786 lbs	1631 lbs

Standard features

- **Radio remote control**
Provided with display & double battery
- **On board diagnostics**
- **12V auxiliary socket**
- **Non-marking tracks**
- **Front and rear hazard ligths**
- **Three different driving modes**
MAIN / ED-S / DC-S
- **Three power management configurations**
ECO / STD / POW
- **Automatic tilt alarm with speed reduction**



The platform sits on a freely rotating slewing ring with 15 different positions that you can manually choose from. Easily adapt the platform to your load needs.

SWIWEL PLATFORM

ADAPTIVE ROLLERS

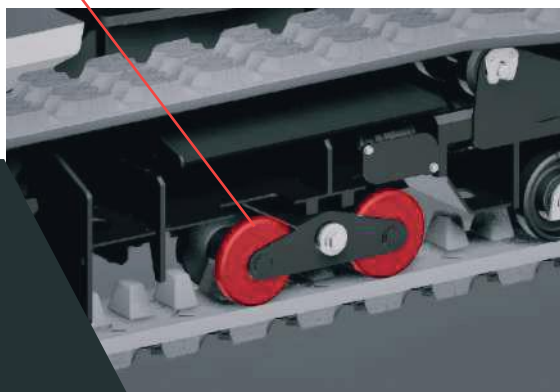

Increased accessibility and gradeability due to unique track design. The rollers actively adapt to the terrain, ensuring grip and avoiding accidental load spills.

MULTI LOADER 3.0 FX

DIMENSIONS

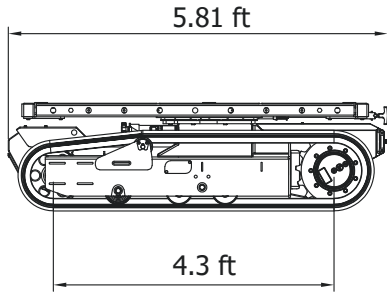

WEIGHT WITHOUT
BATTERY 1411 lbs

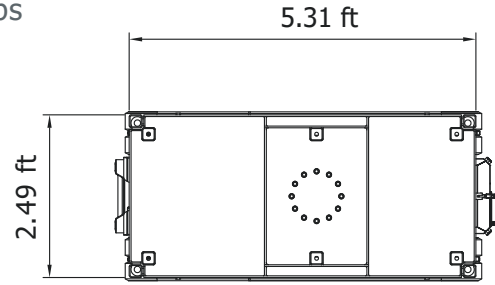
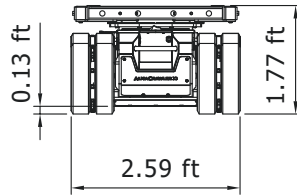
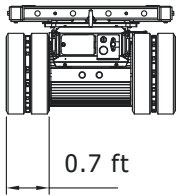

BATTERY PACK

ELC Battery Pack 375 lbs
LTH Battery Pack 220 lbs

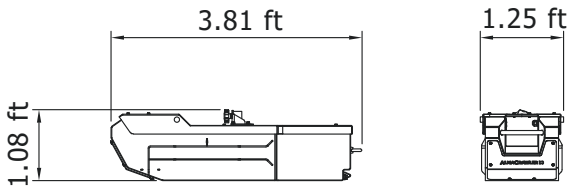

TELESCOPIC SUPPORT BEAMS

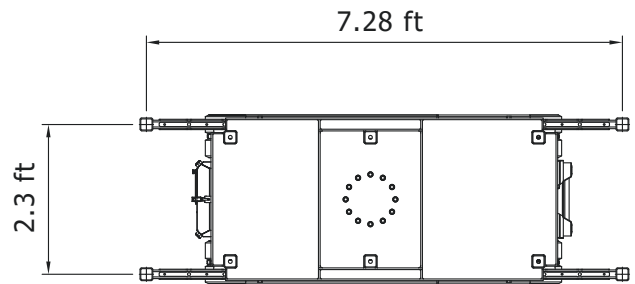

SWIVEL PLATFORMS

