



The Lifting Professionals

Bolingbrook, IL
(630) 972-9199

South Holland, IL
(219) 972-9199

[Click Here to Request a Quote](#)



RK11-311 MK II

PORTABLE CRANE

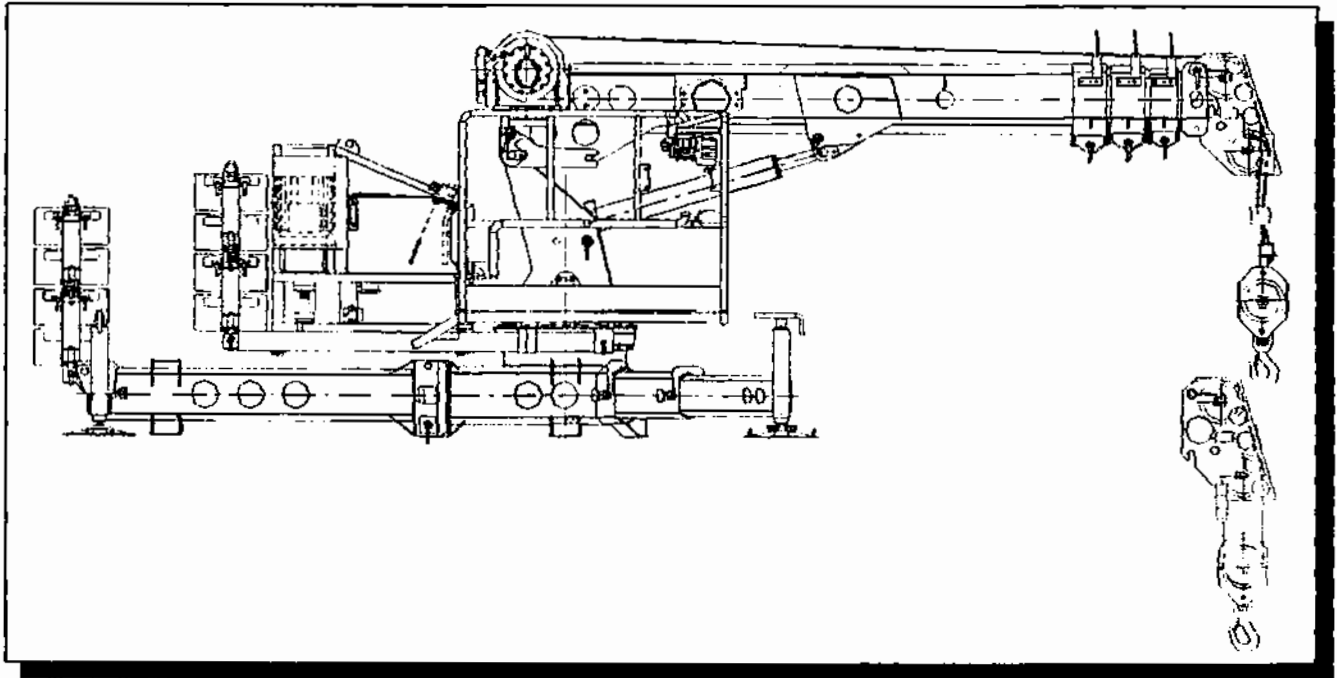



TECHNICAL DATA - RK 11-311 MK II

DESCRIPTION	EUROPE	USA/CANADA
LIFTING TORQUE	112.4 kNm (11.5 tm)	82902 lb ft
HYDRAULIC OUTREACH	10.3 m	33.80 ft
HYDRAULIC BOOM EXTENSION	6.635 m/23 sec	21.80 ft/sec
SLEW ROTATION	630°/63 sec	630°/63 sec
SLEW SPEED	10°/sec	10°/sec
BOOM ELEVATION RANGE	-25°-+80°	-25°-+80°
BOOM ELEVATION SPEED	Up 22 sec Down 14 sec	Up 22 sec Down 14 sec
MAX HOOK HEIGHT UNDER SLEW	10.7 m	35.10 ft
MAX HOOK HEIGHT 1-PART LINE	225 m	738 ft
PUMP FLOW	68 l/min	17.5 g/min
MAX WORKING PRESSURE	330 Bar	4620 psi
POWER SUPPLY	3-phase 380 V 50 Hz	3-phase 230 V 60 Hz
CONTROL VALVE	Proportional direct controlled	Proportional direct controlled
HYDRAULIC TANK CAPACITY	160 l	42 g
WINCH MAX SINGLE LINE PULL		
• HOISTING BARE DRUM	2662 kg	5868 lb
• HOISTING HALF DRUM	2091 kg	4610 lb
• HOISTING FULL DRUM	1800 kg	3970 lb
WINCH MAX SINGLE LINE SPEED		
• HOISTING	55 m/min	180 ft/min
• LOWERING	157 m/min	515 ft/min
WINCH STD STORAGE CAPACITY (consult factory for alt. Capacity)	235 m	771 ft
WIRE ROPE	Rotation resistant Ø 11mm	Rotation resistant Ø 11mm
OUTRIGGER WIDTH/ EXTENDED	3880 mm	12.72 ft
TOTAL CRANE WEIGHT	6200 kg	13670 lb



RK 11-311 MKII TOTAL RATED LOADS (Lb)

OUTRIGGERS AND STABILIZERS FULLY
EXTENDED AND MACHINE LEVEL

MEETS ANSI B30.5
REQUIREMENTS

BOOM LENGTH IN ft WORKING RADIUS IN ft	12.5	18.4	25.6	33.5
	2.8	22,266	22,266	
5.4	14,550	11,464	11,420	11,376
5.7	13,845	11,464	10,803	10,736
6.6	12,125	10,406	9,480	9,370
8.2	9,700	8,333	8,091	7,275
9.8	8,377	7,187	6,746	6,393
11.5	7,209	6,283	6,173	5,512
13.1		5,512	5,401	5,071
14.8		4,982	4,806	4,541
16.4		4,586	4,299	4,101
19.7			3,593	3,417
23.0			3,086	2,954
26.2				2,601
29.5				2,315
31.2				2,006
32.8				1,742
34.1				1,675

DEDUCTIONS

FACTORY SUPPLIED:

- 1-SHEAVE HOOK BLOCK 89 Lb
- 3-SHEAVE HOOK BLOCK 168 Lb
- 3-SHEAVE BOOM TIP HEAD 89 Lb



SCAN TECH (Thailand) CO., LTD.



RK 11-311 MKII

TOTAL RATED LOADS (Lb): FLY JIB

OUTRIGGERS AND STABILIZERS FULLY EXTENDED AND MACHINE LEVEL

MEETS ANSI B30.5 REQUIREMENTS

BOOM LENGTH IN ft WORKING RADIUS IN ft	21		27		34		42	
	∠°	lb	∠°	lb	∠°	lb	∠°	lb
7	80	3970						
10	76	3970	80	3970				
11	73	3970	78	3970	80	3970		
13	60	3970	70	3970	75	3970	80	3970
16	55	3970	65	3970	71	3970	75	3745
18	45	3970	60	3970	67	3630	72	3500
20	28	3970	54	3172	63	3570	69	3280
21	0	3135	51	2980	60	3276	67	3030
23			45	3400	57	3120	64	2850
25			36	2350	52	2840	60	2698
26			28	2936	50	2720	59	2610
27			0	2070	45	2620	57	2465
32					28	2193	48	2230
34					0	1450	43	2020
36							38	1860
39							28	1719
42							0	1080

DEDUCTIONS

FACTORY SUPPLIED:

- 1-SHEAVE HOOK BLOCK 89 Lb
- 3-SHEAVE HOOK BLOCK 168 Lb
- 3-SHEAVE BOOM TIP HEAD 89 Lb



SCAN TECH (Thailand) CO., LTD.

RK11-311 MKII WORKING RANGE / RATED LOAD

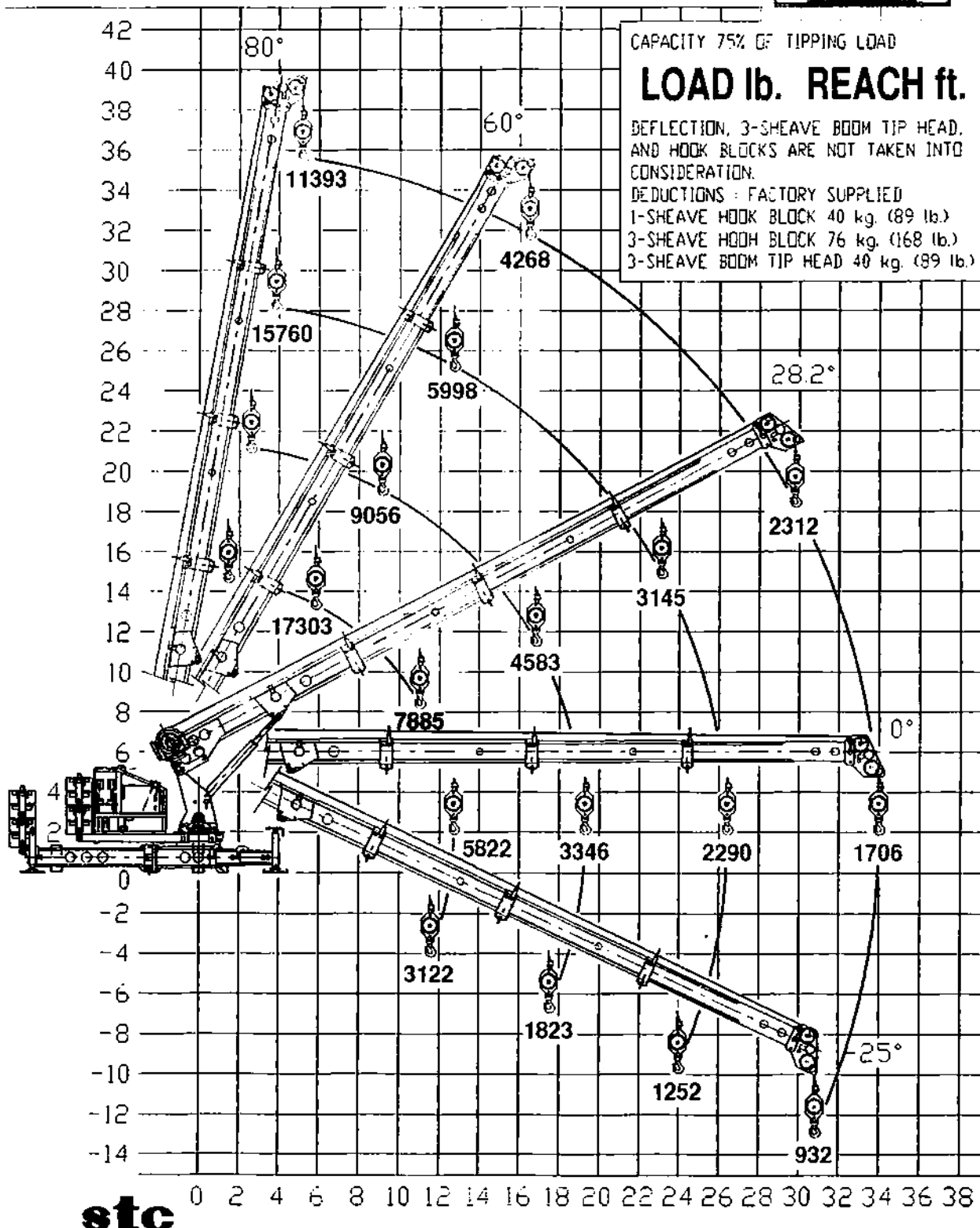

stc



MEETS ANSI B30.5 REQUIREMENTS

RK11-311 MKII / FLY JIB WORKING RANGE / RATED LOAD

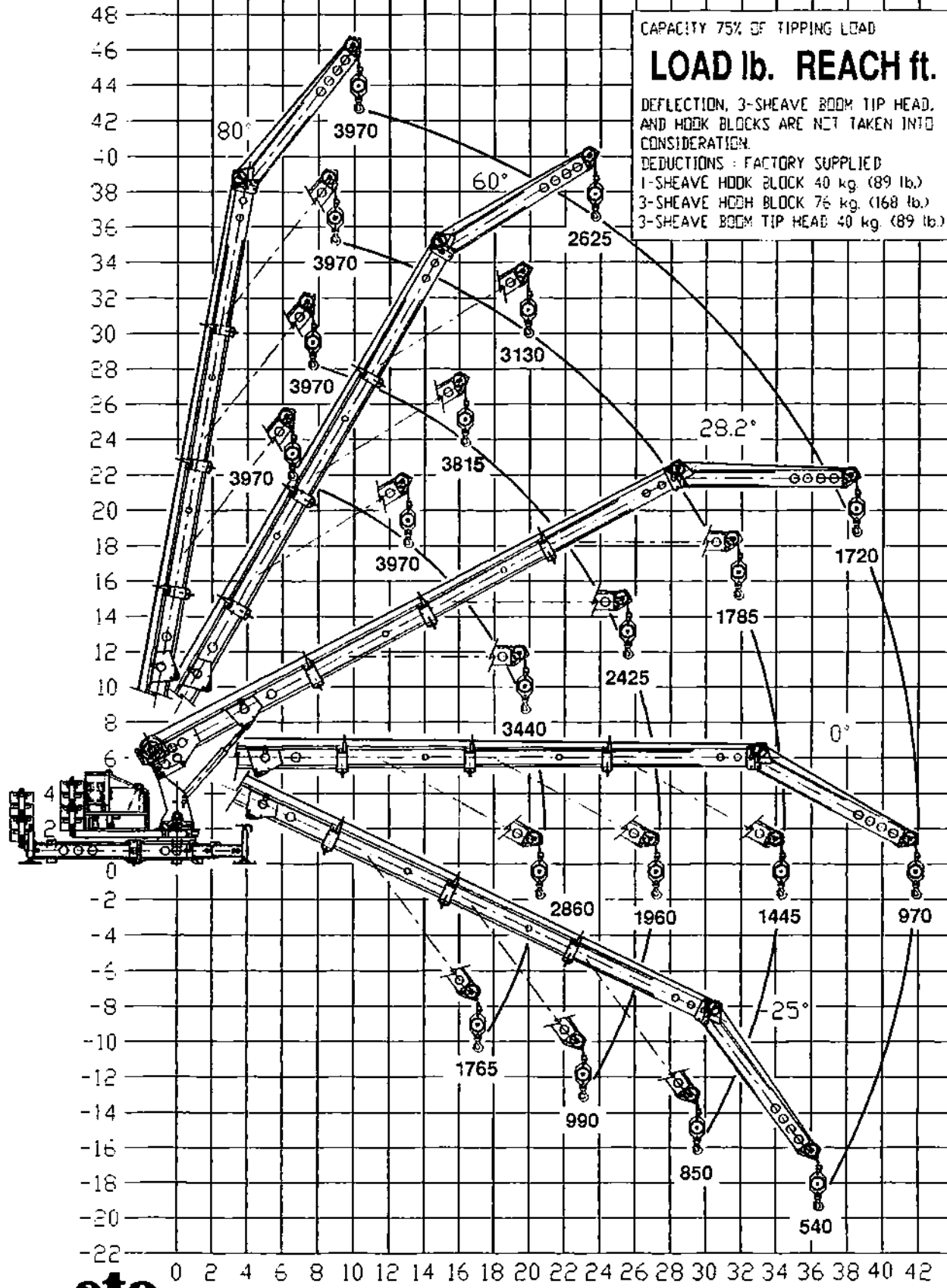

CAPACITY 75% OF TIPPING LOAD

LOAD lb. REACH ft.

DEFLECTION, 3-SHEAVE BOOM TIP HEAD, AND HOOK BLOCKS ARE NOT TAKEN INTO CONSIDERATION.

DEDUCTIONS : FACTORY SUPPLIED

- 1-SHEAVE HOOK BLOCK 40 kg. (89 lb.)
- 3-SHEAVE HOOK BLOCK 76 kg. (168 lb.)
- 3-SHEAVE BOOM TIP HEAD 40 kg. (89 lb.)

stc



MEETS ANSI B30.5 REQUIREMENTS

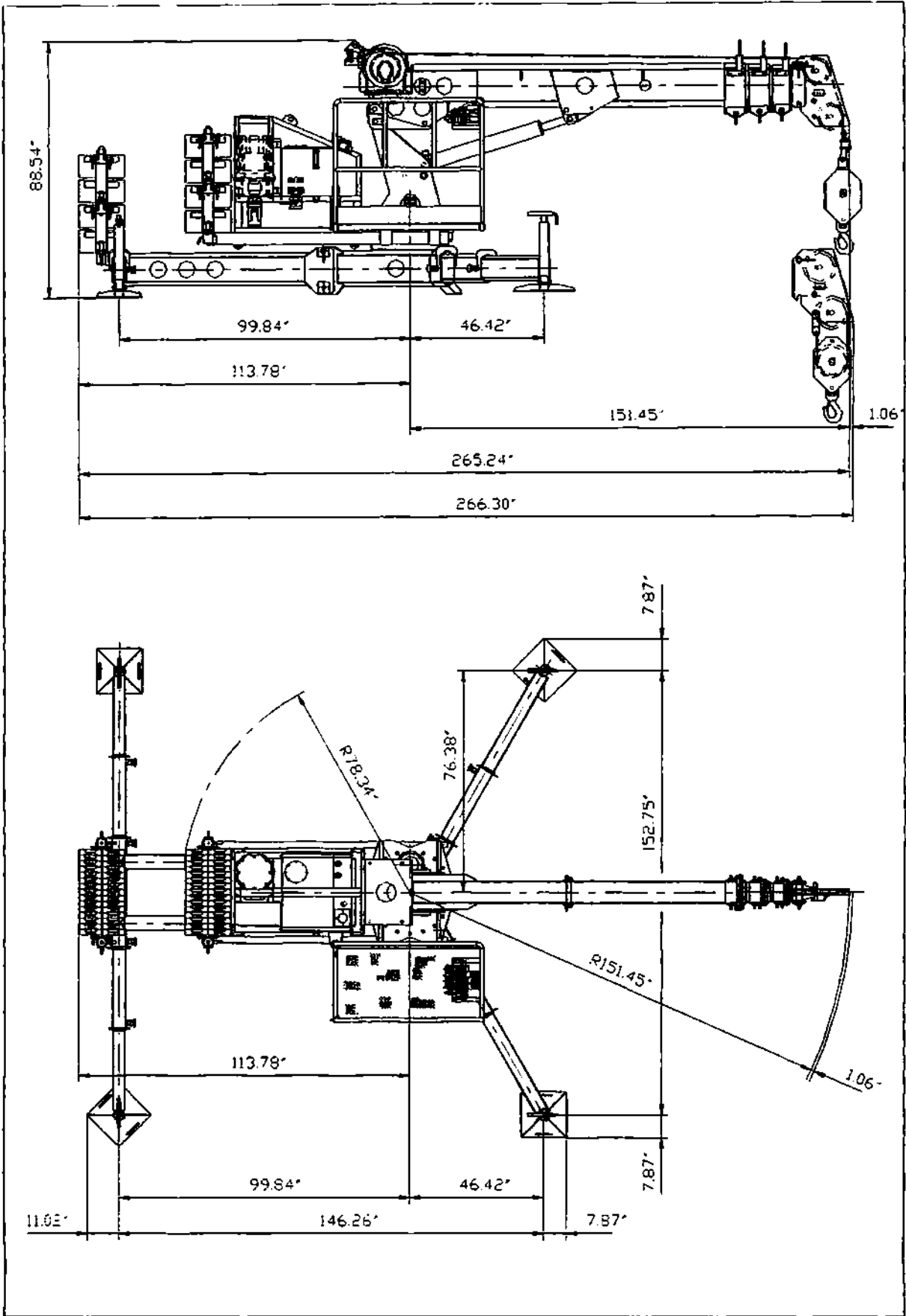

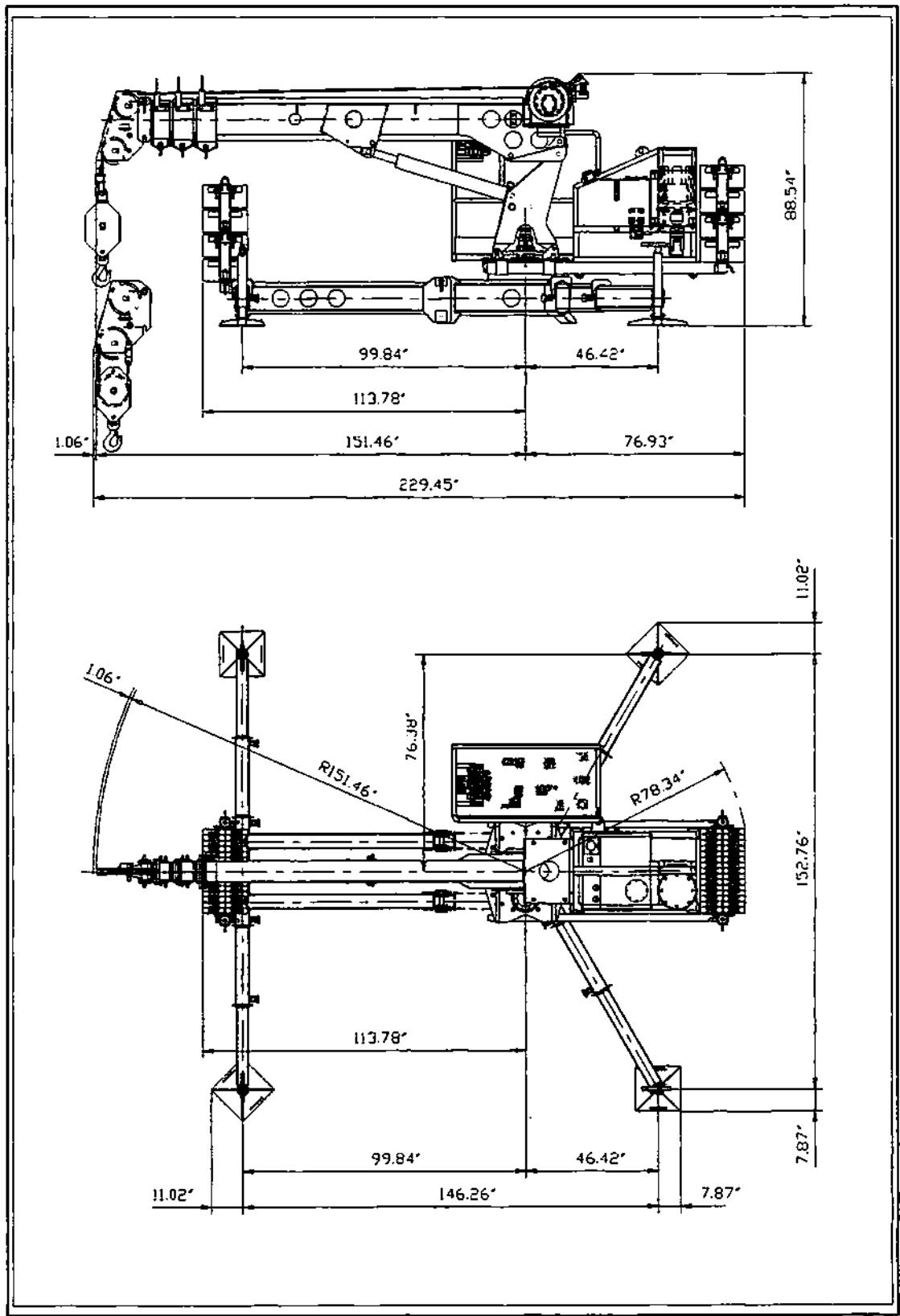

CORNER PRESSURE (imperial). Load = 2312 Lb – Radius = 29.63 ft

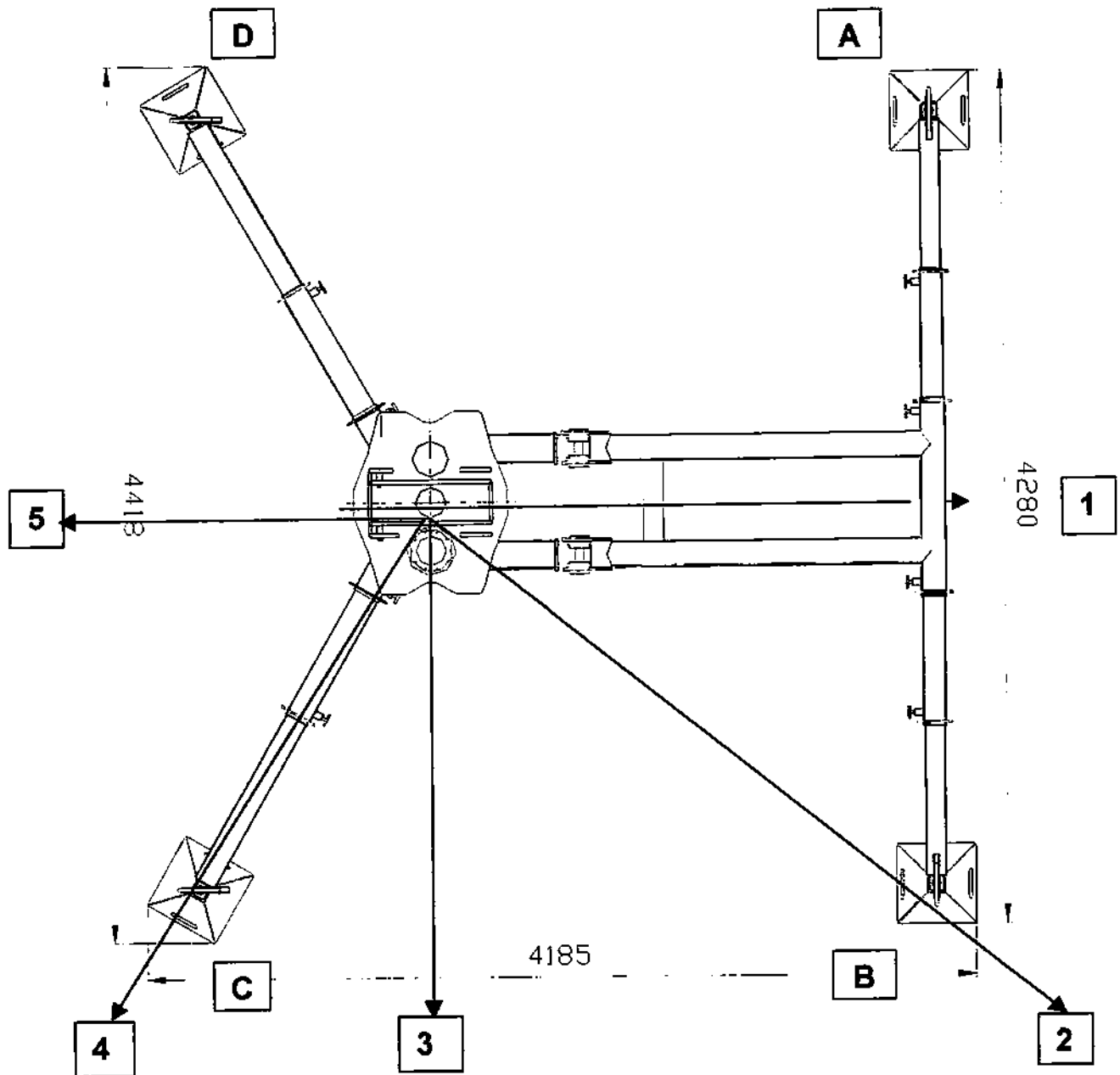

CORNER \ JIB POSITION	A	B	C	D
1	7427 Lb	7427 lb	-	-
2	2848 Lb	6824 Lb	3016 Lb	-
3	-	4748 Lb	10211 Lb	-
4	-	4123 Lb	6527 Lb	2398 Lb
5	-	-	7744 Lb	7744 Lb

CORNER PRESSURE (imperial). Load = 17303 Lb – Radius = 6.32 ft

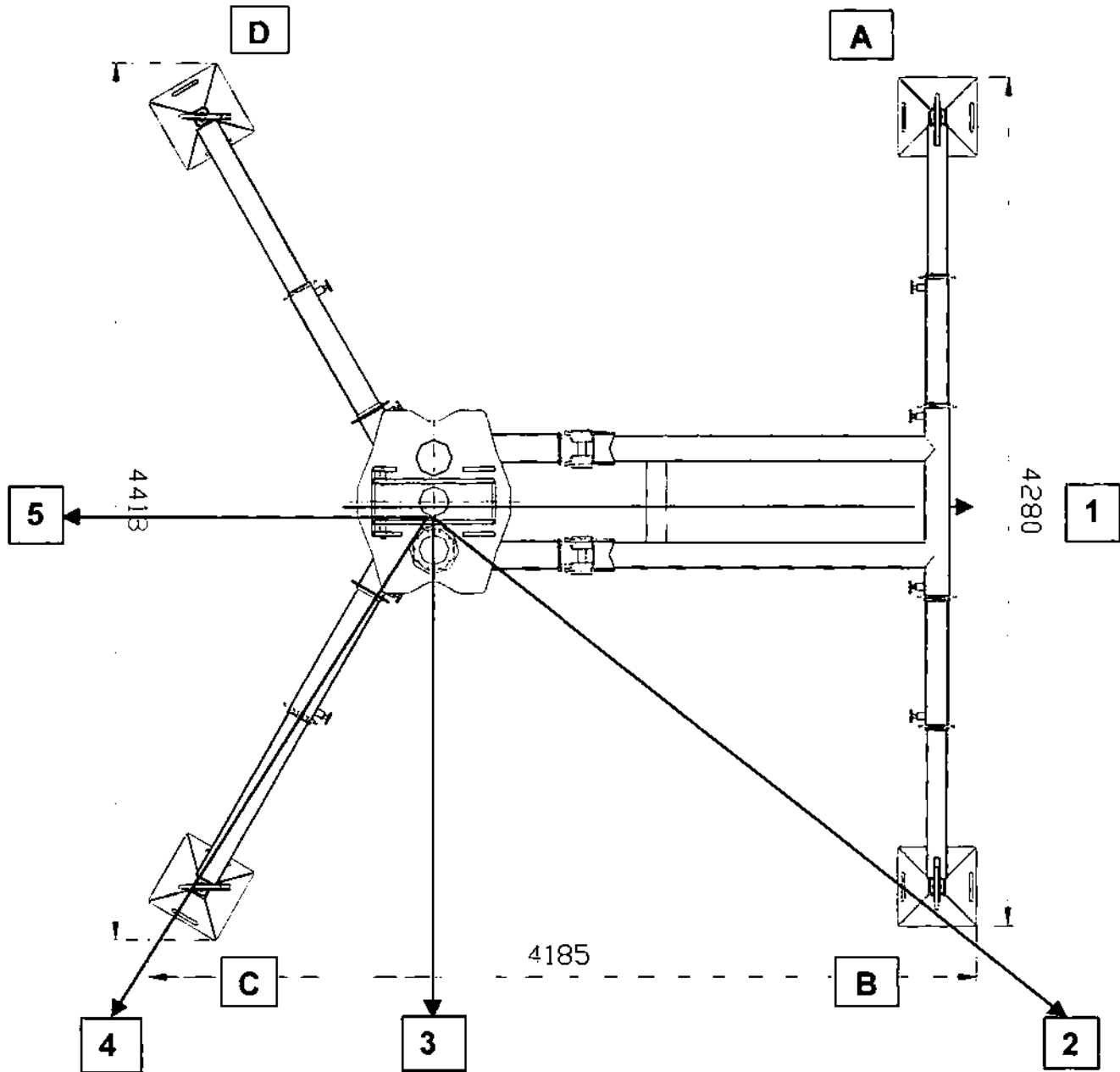

CORNER \ JIB POSITION	A	B	C	D
1	12161 Lb	12161 Lb	-	-
2	5140 Lb	12312 Lb	5439 Lb	-
3	-	8889 Lb	19111 Lb	-
4	-	8435 Lb	13353 Lb	4904 Lb
5	-	-	16178 Lb	16178 Lb