



Technical Data

Specification & Capacities

JF545

OVERALL DIMENSIONS

(with jib and low marking pads)

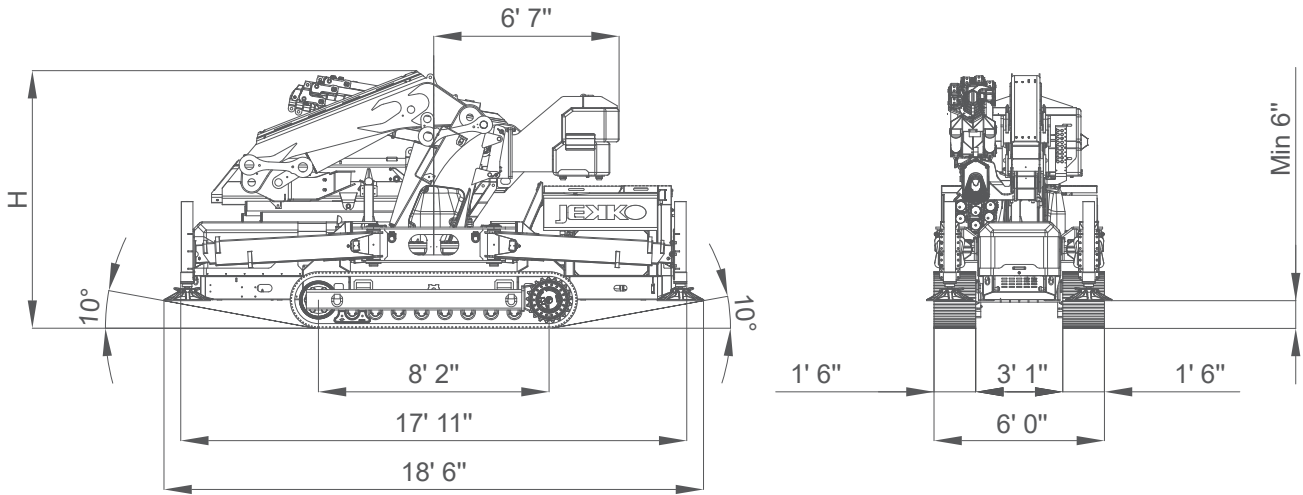

H=9' 3" with V20 winch / H=9' 6" with V30 winch

STABILIZATION AREA

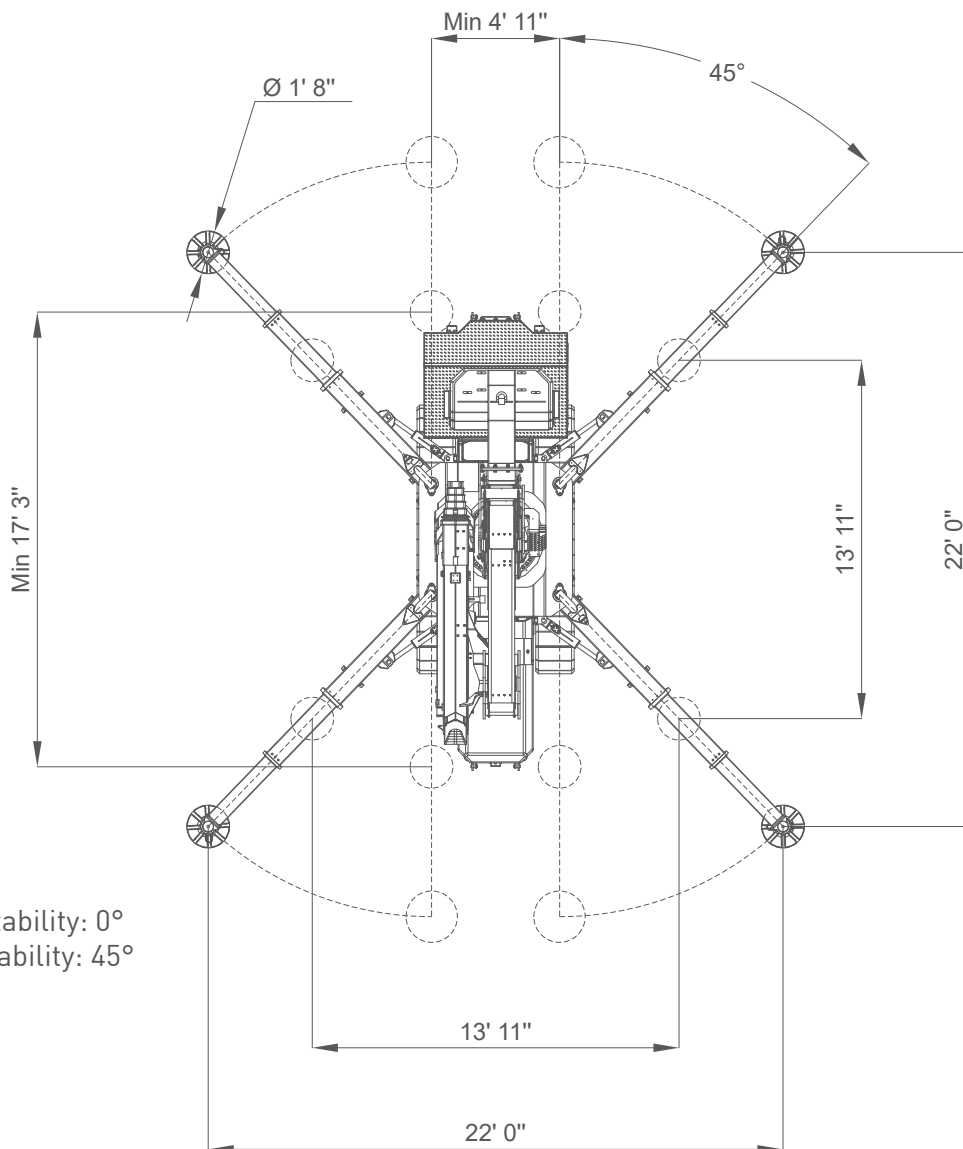

Min angle stability: 0°
Max angle stability: 45°

CRANE PERFORMANCE

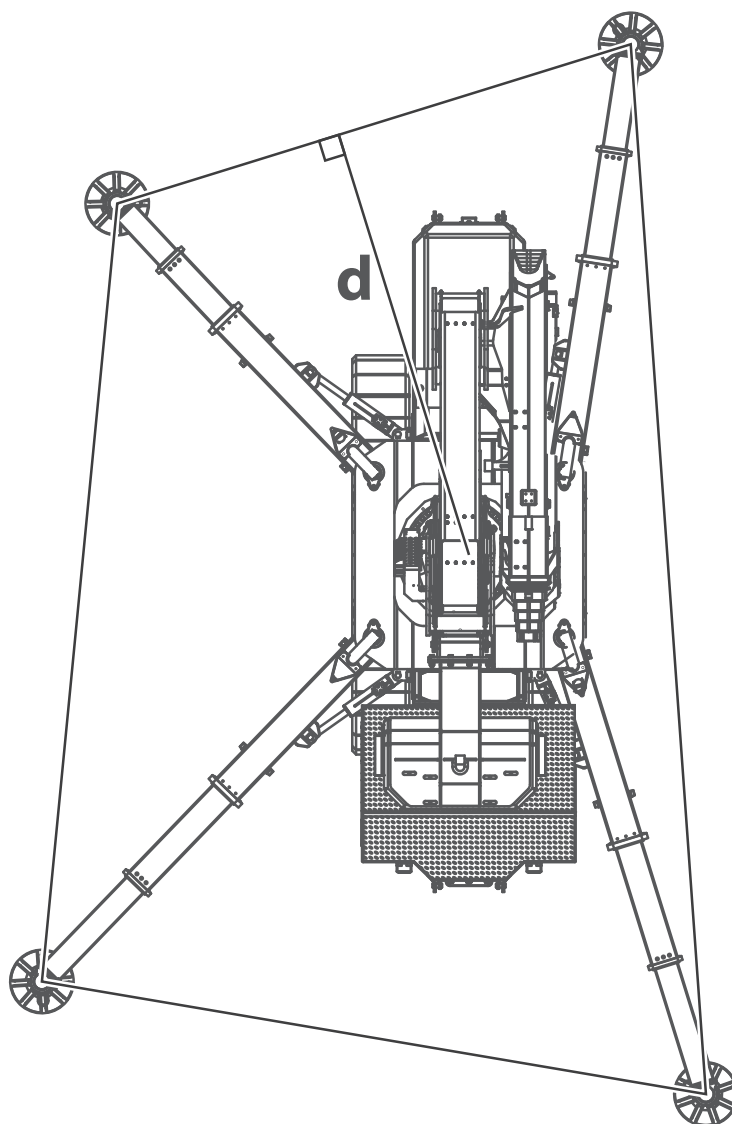

K	d min	d max
K1	5' 3"	6' 7"
K2	6' 7"	8' 6"
K3	8' 6"	10' 2"
K4	10' 2"	10' 6"
K5	10' 6"	-

STABILIZATION CHART

The division into 4 areas is a schematic representation, software adapts pressure level continuously.

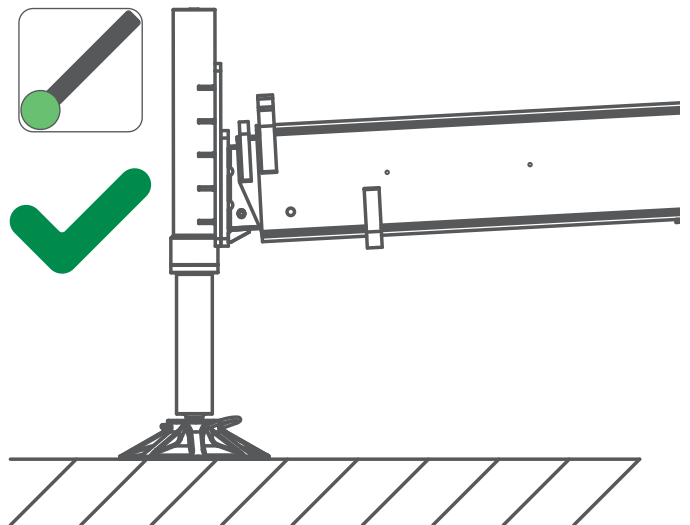
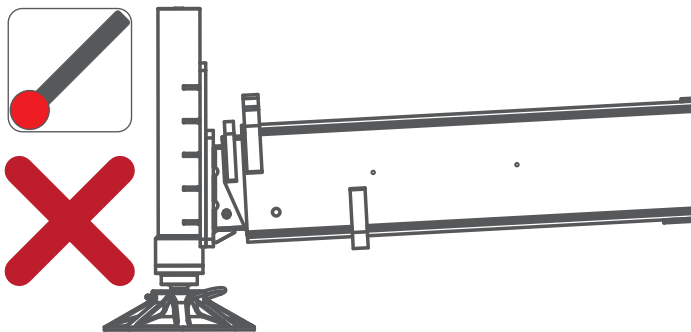
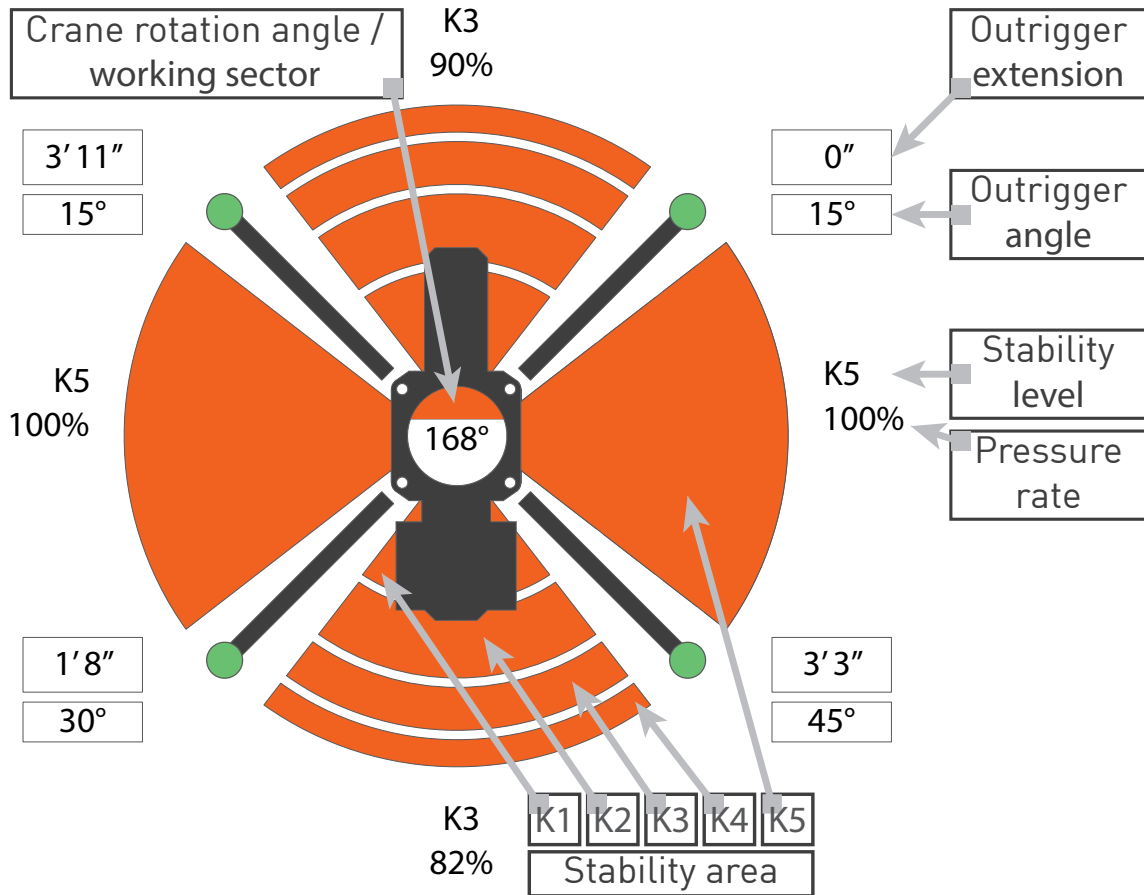

STABILIZATION ADJUSTMENT

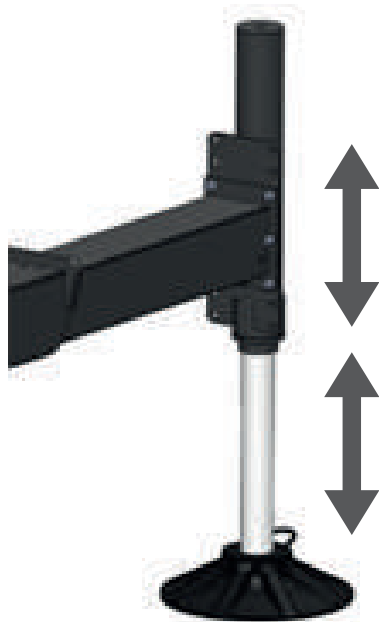
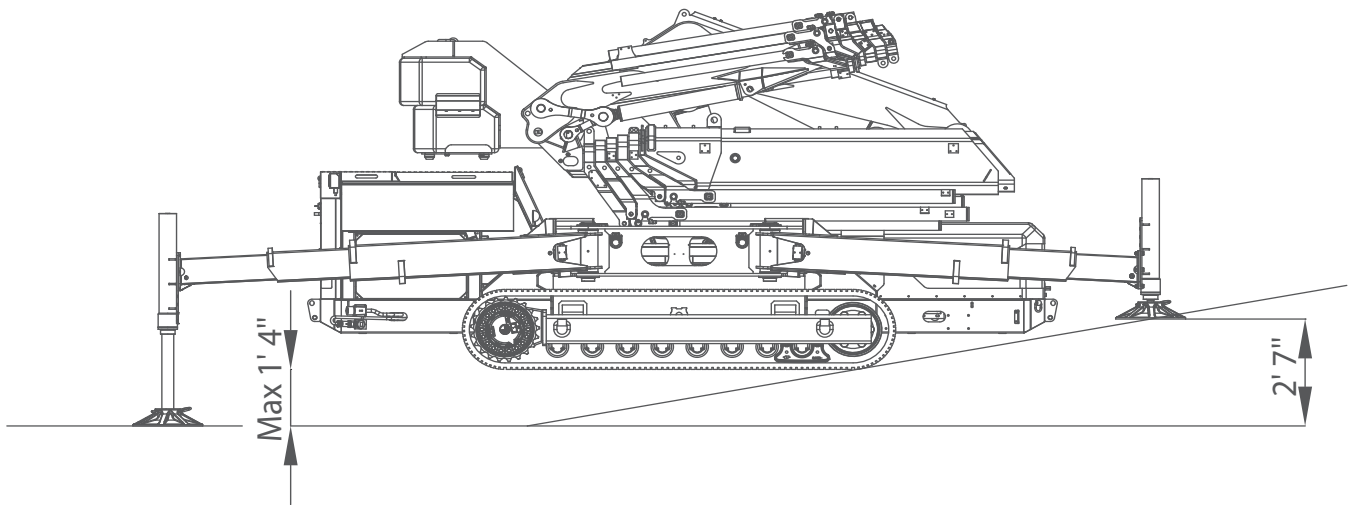

FLANGE ADJUSTMENT: $\pm 5''$

CYLINDER STROKE: $\pm 1' 10''$

JF545 - MAIN BOOM

with HOOK

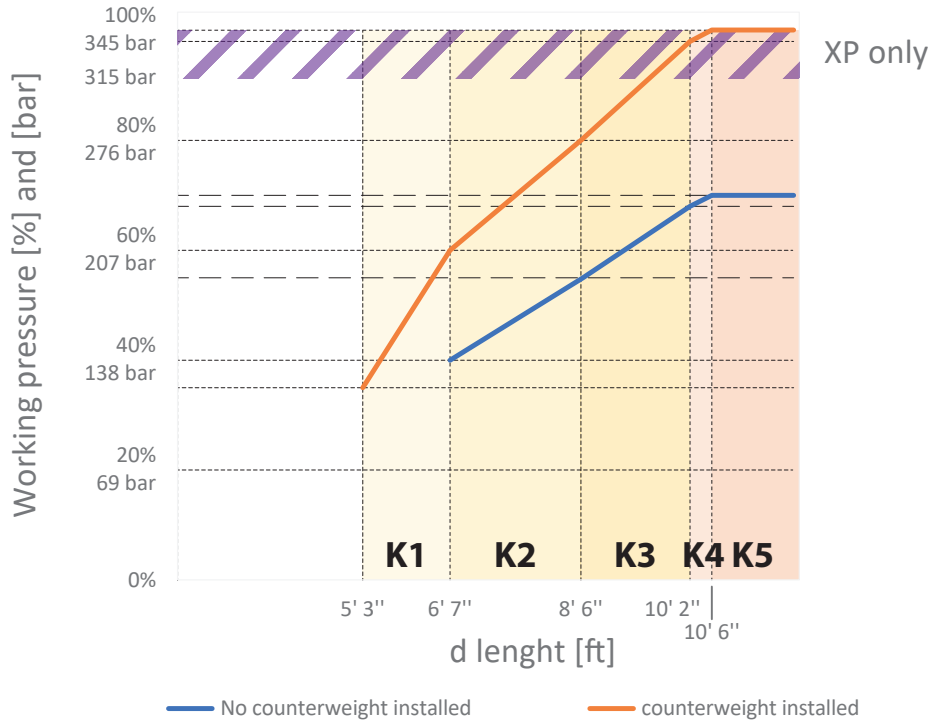

with WINCH

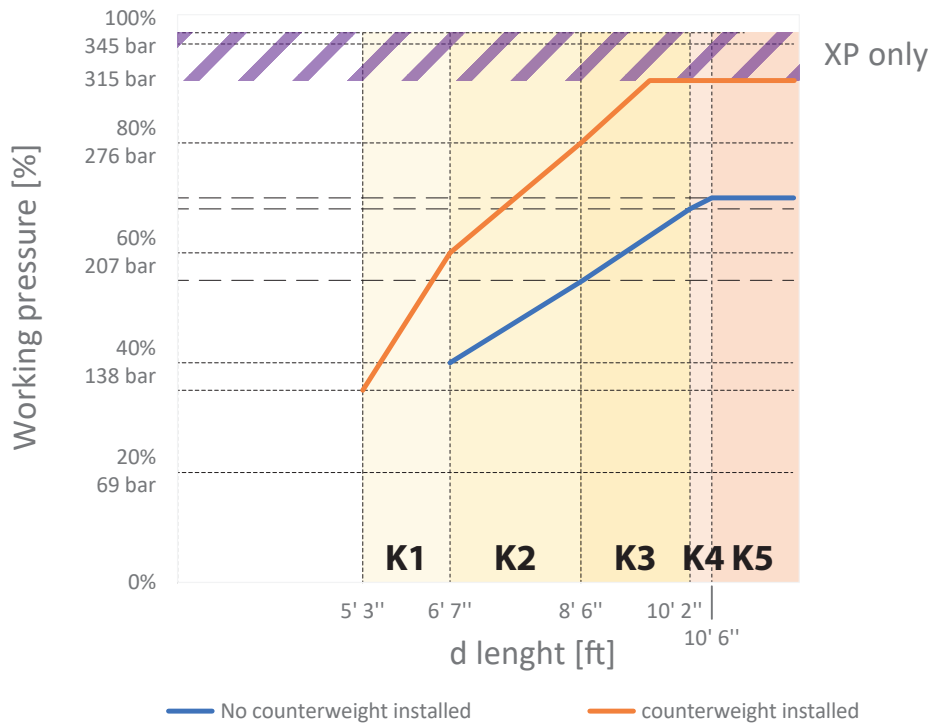

JF545 - JIB3000.6HA



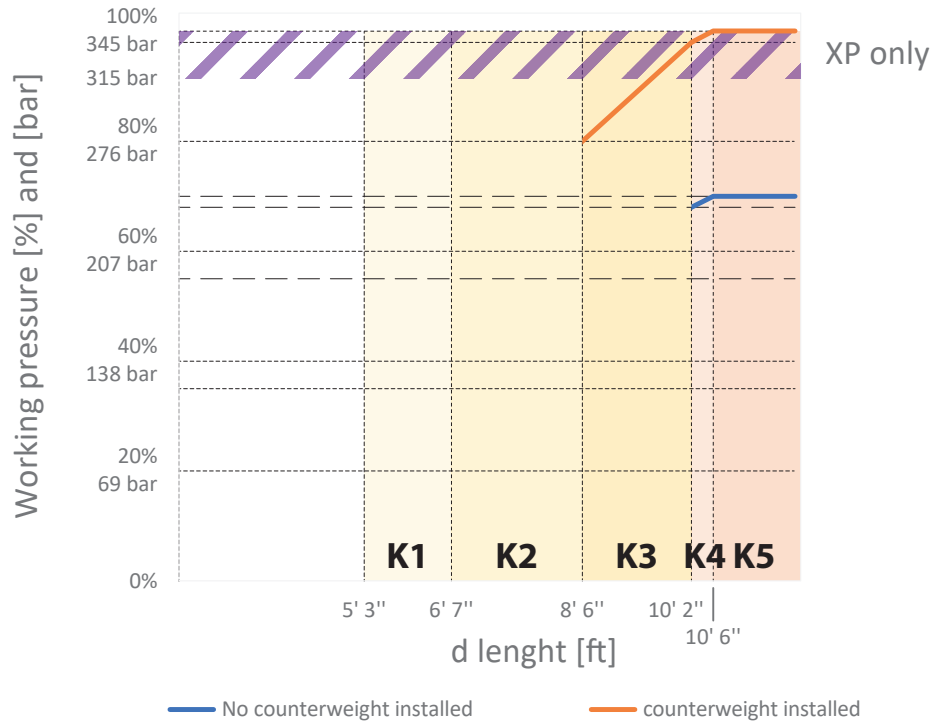

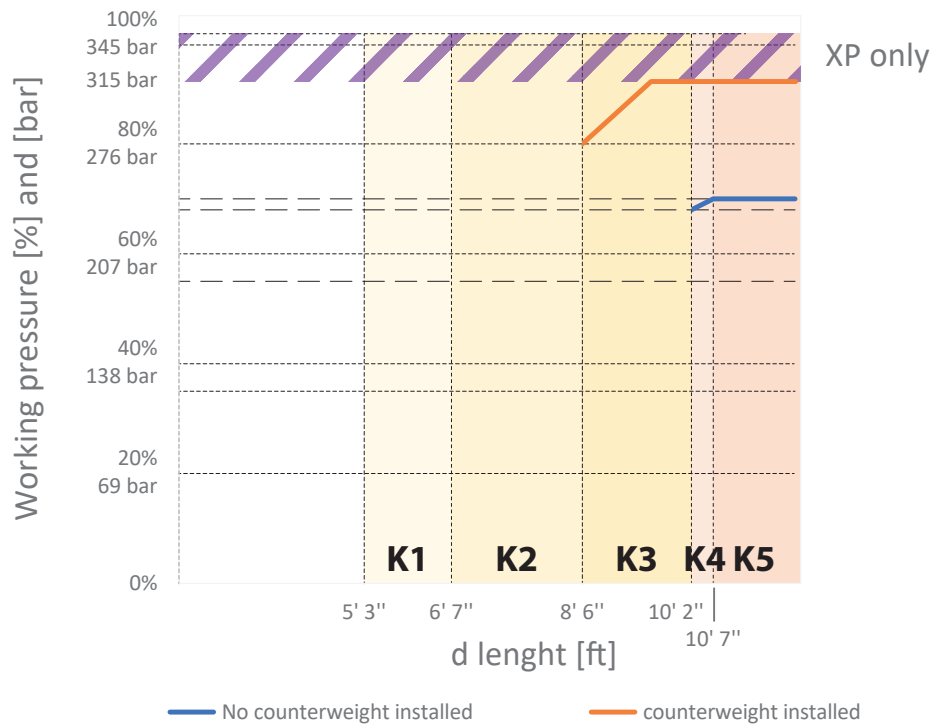

with HOOK













with WINCH



OVERALL INFORMATIONS

		Name/ version	lb*
WEIGHTS	 Crane	ALL	29,762
	 Counterweight	ALL	7,716
	 Winch	W2000-JFM	441
		W3000-JFM	441
	 Hookblock	SINGLE FALL	103
		DOUBLE FALL	127
		TRIPLE FALL	125
		JIB SINGLE FALL	165
	 Power Pack	3-PHASE POWERPACK	176
		L426	2,645
	 Jib	MEH-545.6	198
		ME1-545.6	209
		MEH-JIB3000.6HA	50
		ME1-JIB3000.6HA	79
Low marking pads		WTP-JFM	661 (7.5 x 92)
 Outriggers mats	OM500	66	

ENGINE	 Engine	KUBOTA V3307-CR-TE4B	
	KW Power	55,4kW 74HP	
	 Fuel	DIESEL	
	 Tank	gal	19
ELECTRIC	KW Power	400V-3F 13kW 17,4HP	
HYDRAULIC	 Hydraulic Oil	ISO 6743-4:HVLP with VG46 viscosity class	
		Working temp	<158°F
		gal	52
MOVEMENTS	 Travel Speed	km/mph	0,6 / 1,24
	 Gradeability	20° (36%) [†]	
	 Track Load	lb/in ²	170
	 Outrigger Load	lb	24.802 [‡]
	 Working Angle	0°/80°	
		s	Primary: 37 Secondary: 47
	 Slewing	360°	
		rpm	0,67
 Boom Telescoping	ft	60' 0"	
	s	42 [§]	

OIL COOLER	Weight	lb	35
	Voltage	V	12
	Working Temperature	°C	-20 / +40
	Working Pressure	bar	16 / 21
	Fluid Flow	gal/min	47,5

*: Dry weight

†: Engine working limit

‡: Static lifting

§: Timing without load, fully stabilised and without XP

WINCH PERFORMANCE

W2000-JFM				
WINCH	Layer	Max pull line	Standard rope speed	Highest rope speed
		lb	ft/min	ft/min
	1	5,732*	119.72	N/A
	2	5,291*	131.2	N/A
	3	4,850*	142.68	N/A
4	4,497*	154.16	N/A	
ROPE	Wire rope	Ø	Total length	Max load
		in	ft	lb
	Right lang lay	1/2	196' 10"	5291
HOOK BLOCK	Load	N° of		Block type
	lb	Sheaves	Lines	
	13,227	1	3	Triple fall block
	7,716	1	2	Double fall block
	4,409	-	1	Single fall block

W3000-JFM				
WINCH	Layer	Max pull line	Standard rope speed	Highest rope speed
		lb	ft/min	ft/min
	1	8,531†	147.6	N/A
	2	7,859†	160.72	N/A
	3	7,187†	173.84	N/A
ROPE	Wire rope	Ø	Total length	Max load
		in	ft	lb
	Right lang lay	9/16	196' 10"	5,291
HOOK BLOCK	Load	N° of		Block type
	lb	Sheaves	Lines	
	13,227	1	2	Double fall block
	6,613	-	1	Single fall block

*: LMI limited at 4,409 lb

†: LMI limited at 6,613 lb

JF545 - MAIN BOOM

HOOK and FULL COUNTERWEIGHT installed

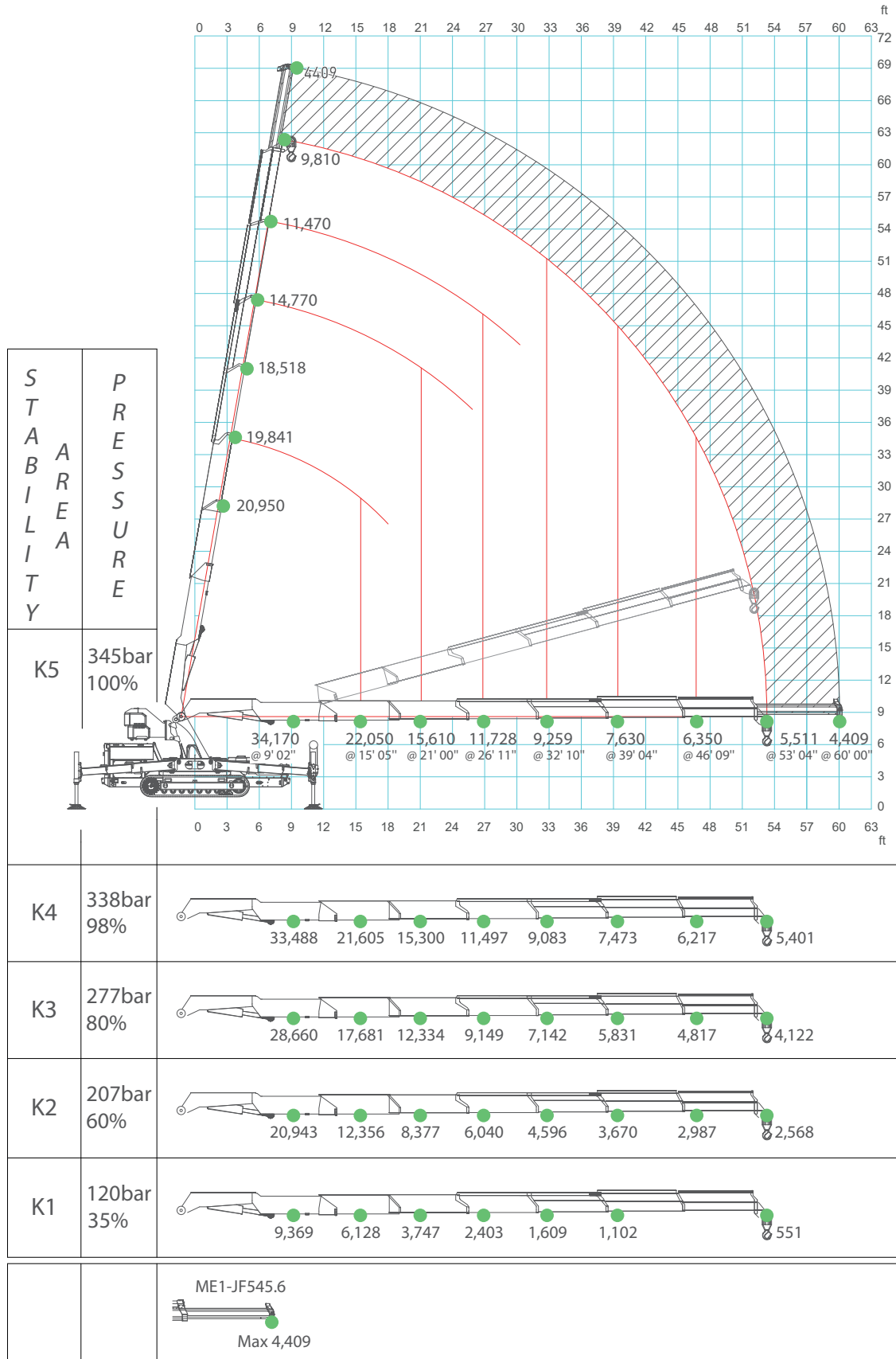

JF545 - MAIN BOOM

W2000-JFM and FULL COUNTERWEIGHT installed

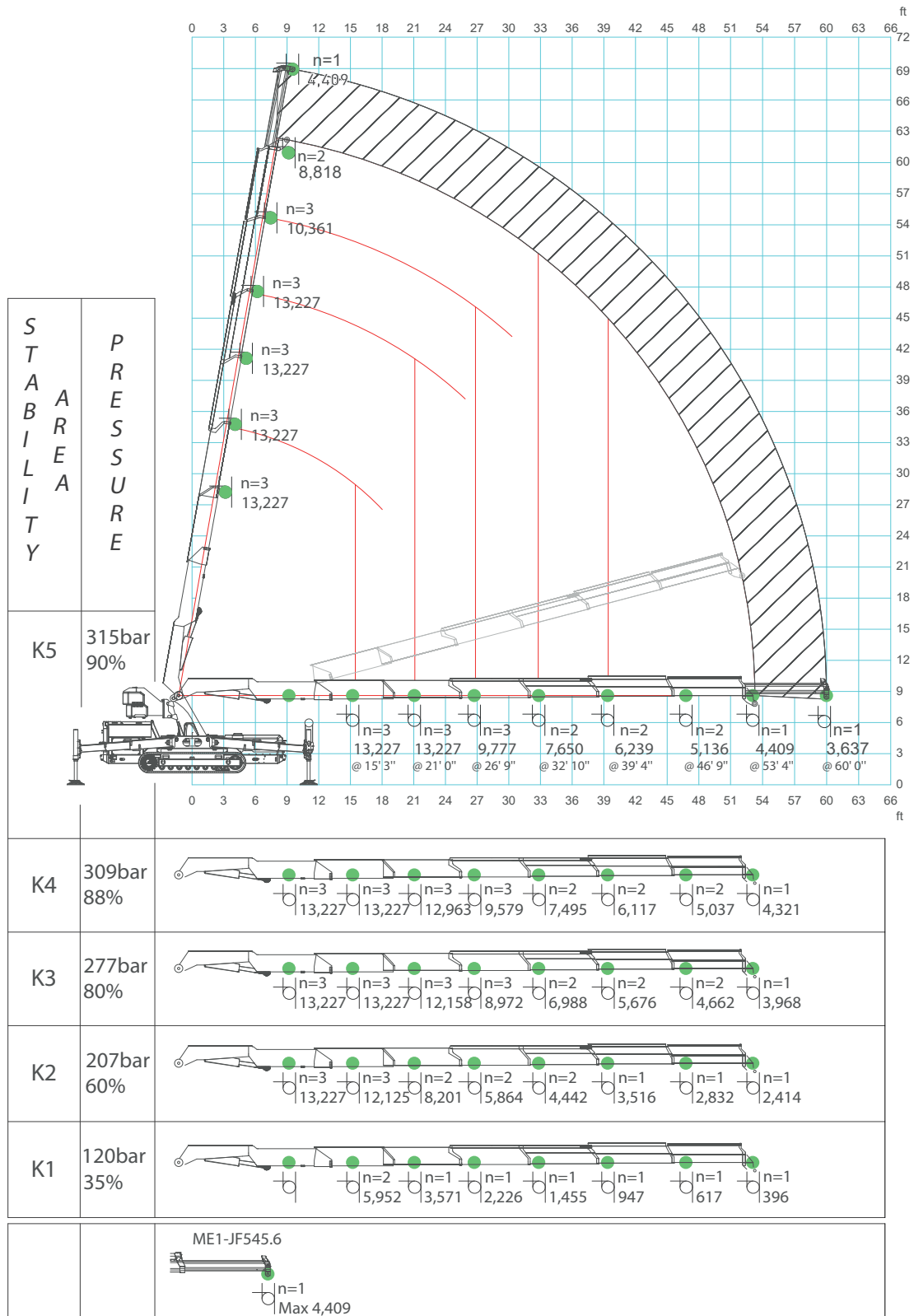

JF545 - MAIN BOOM

W2000-JFM and NO COUNTERWEIGHT installed

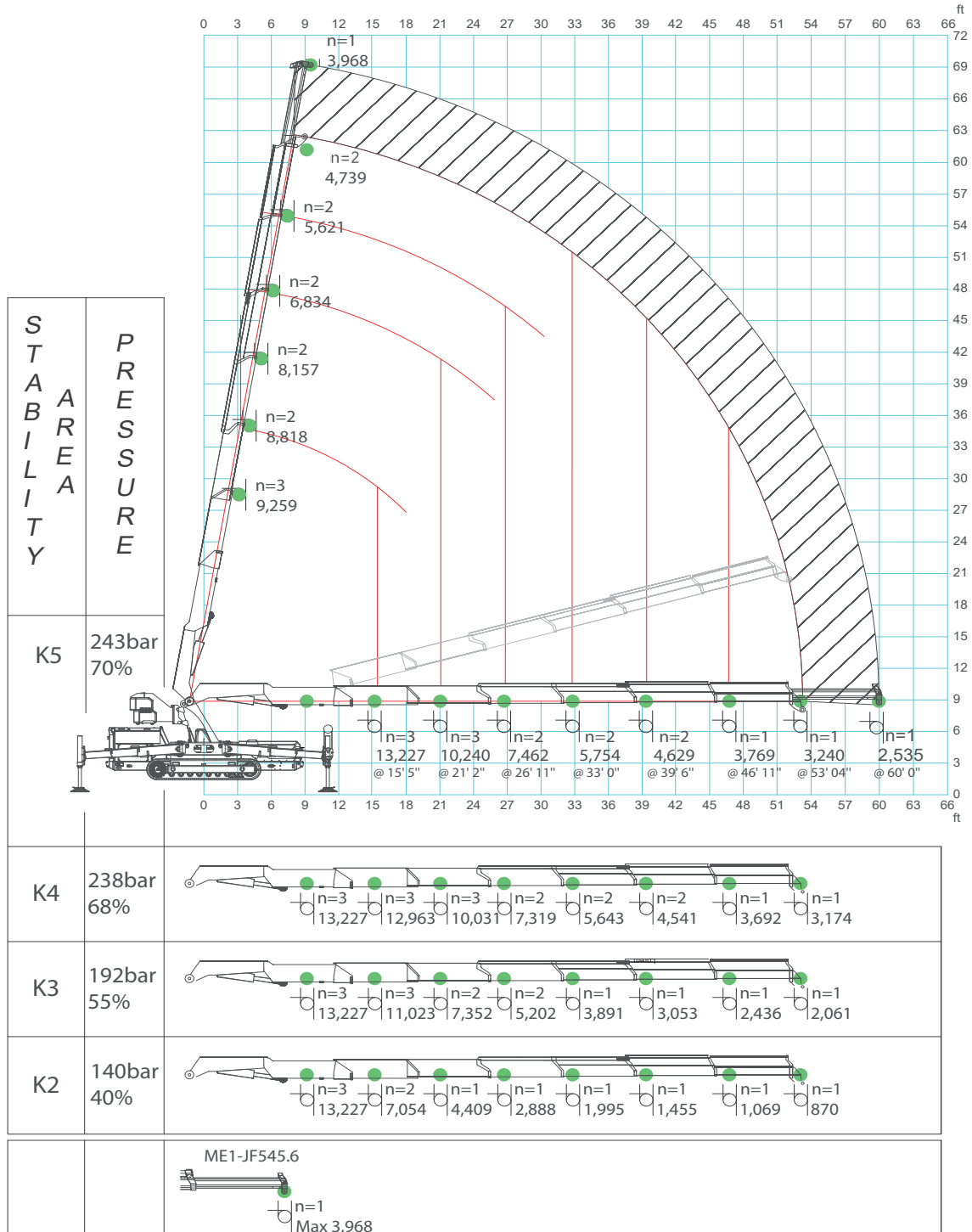

JF545 - JIB3000.6HA

HOOK and FULL COUNTERWEIGHT installed

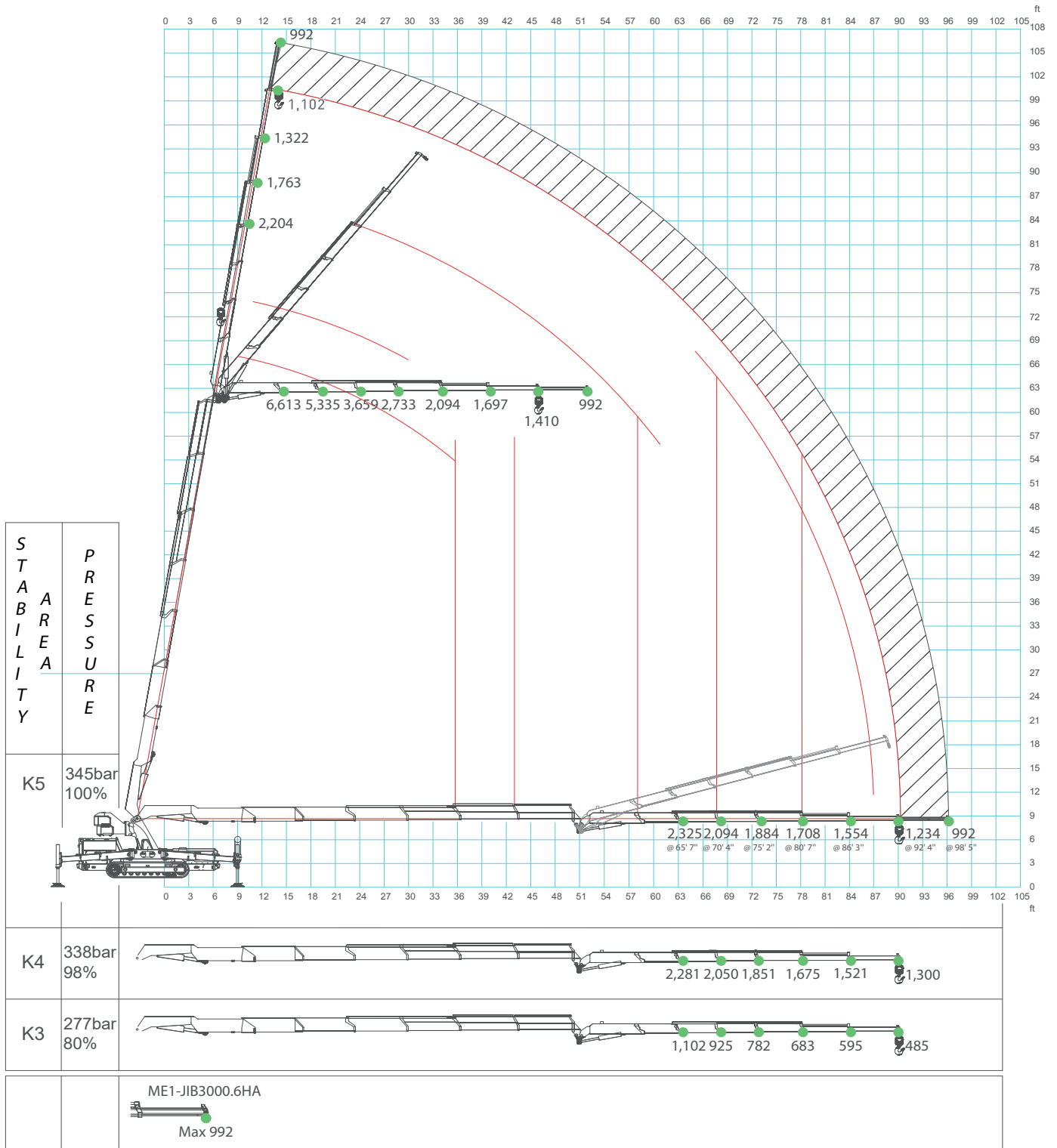

JF545 - JIB3000.6HA

HOOK and NO COUNTERWEIGHT installed

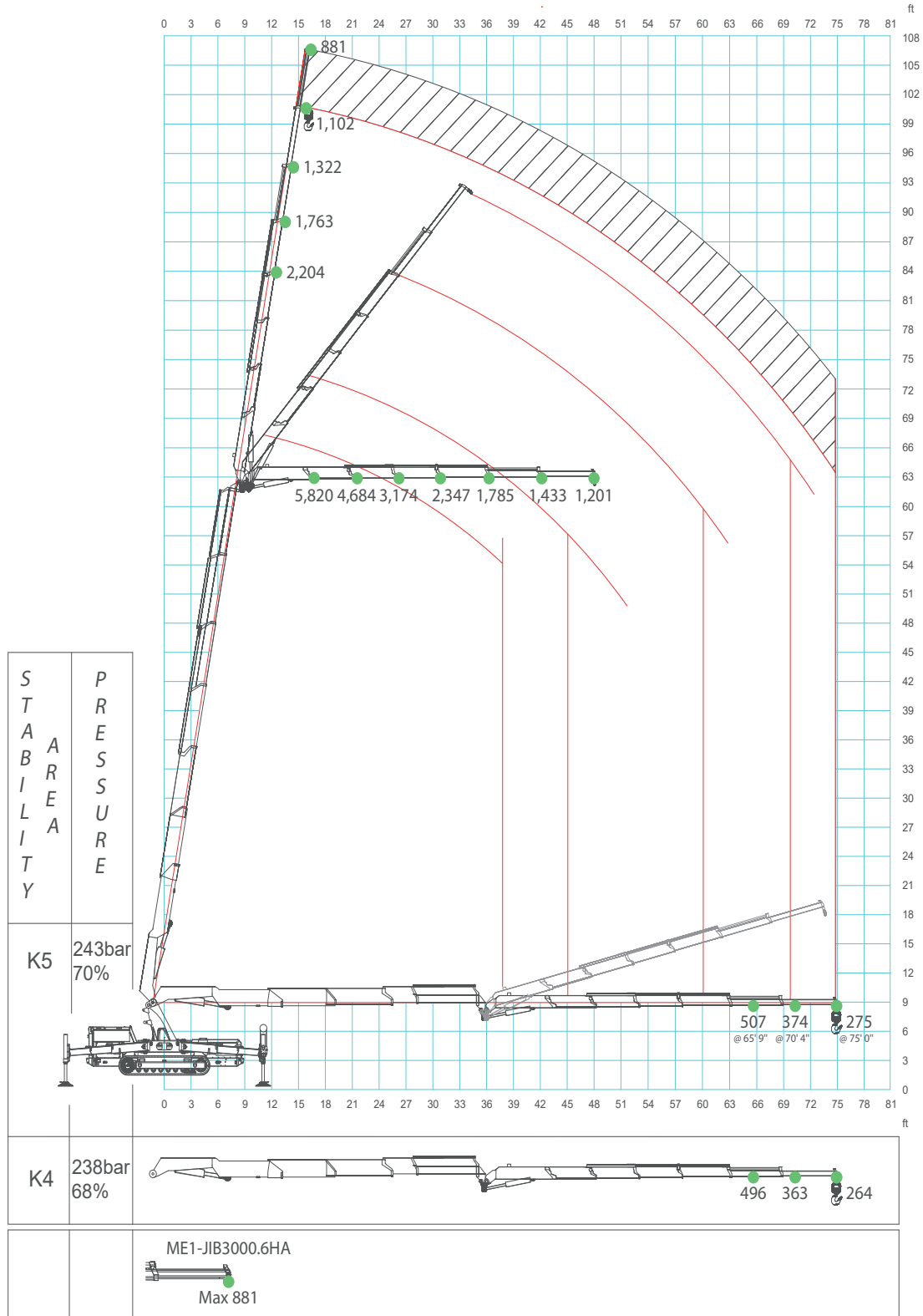

JF545 - JIB3000.6HA

W2000-JFM and FULL COUNTERWEIGHT installed

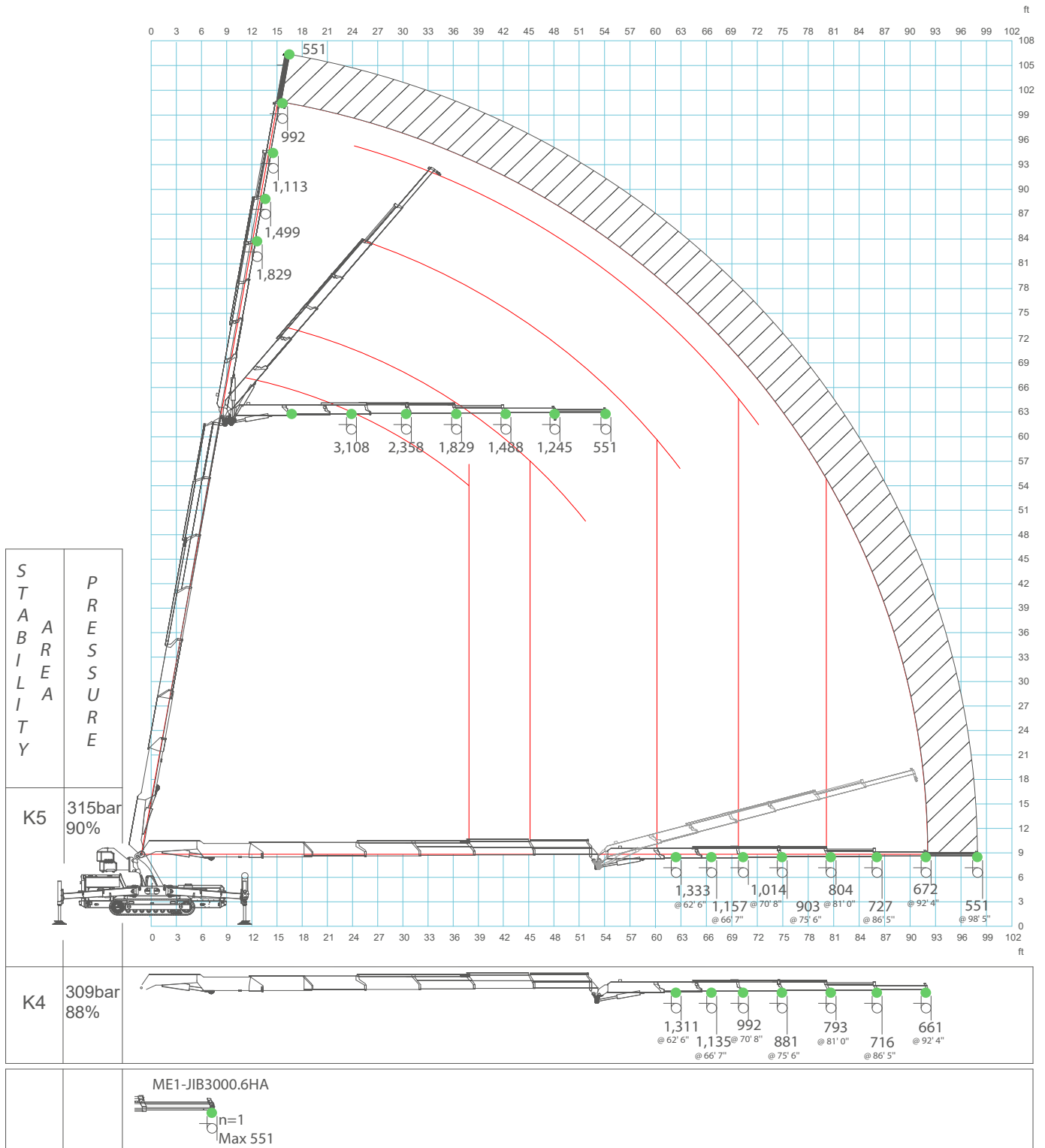

JF545 - JIB3000.6HA

W2000-JFM and NO COUNTERWEIGHT installed

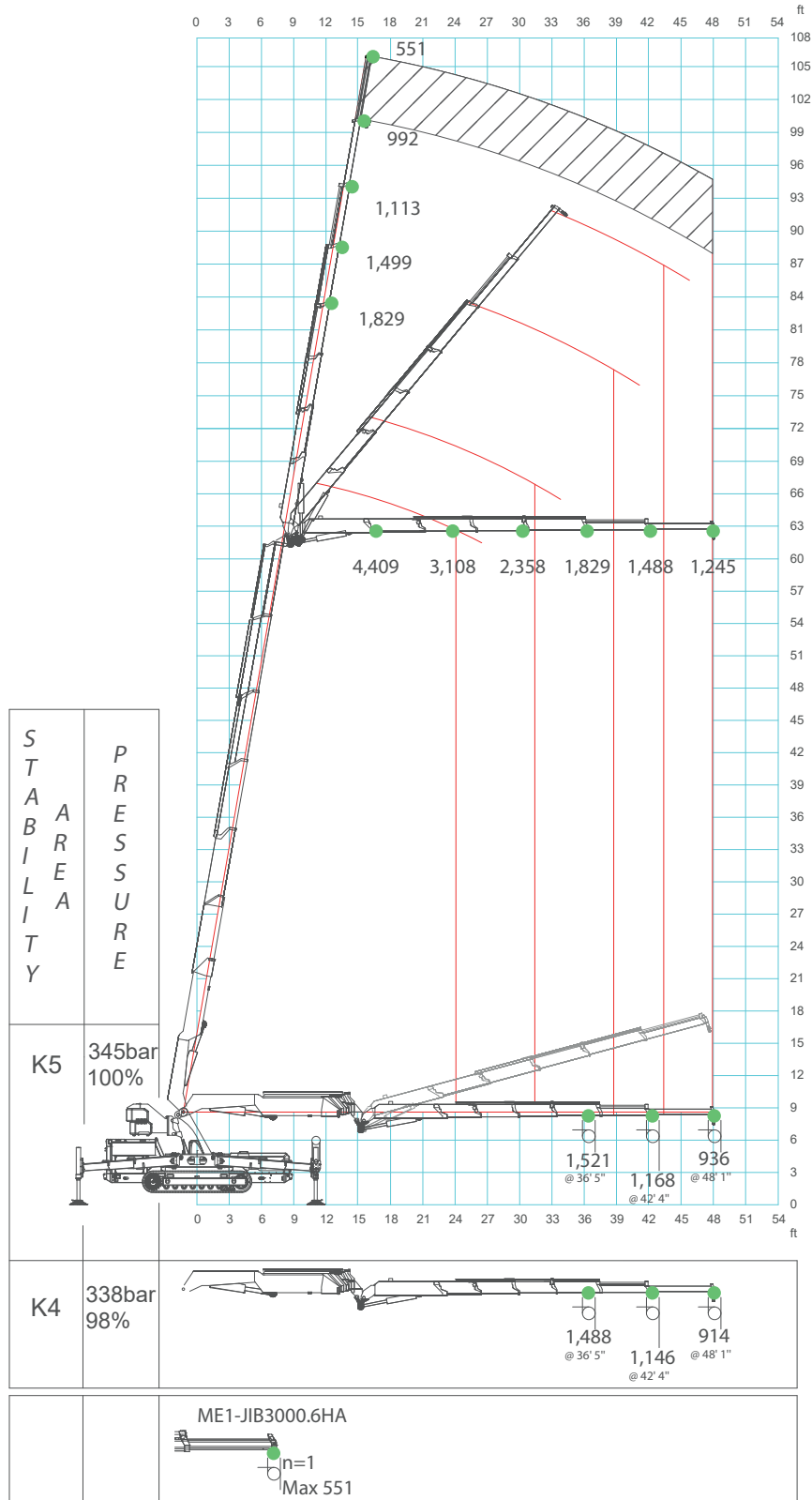

JF545 - STATIC/DYNAMIC LIFTING CAPACITY

W2000-JFM and FULL COUNTERWEIGHT installed

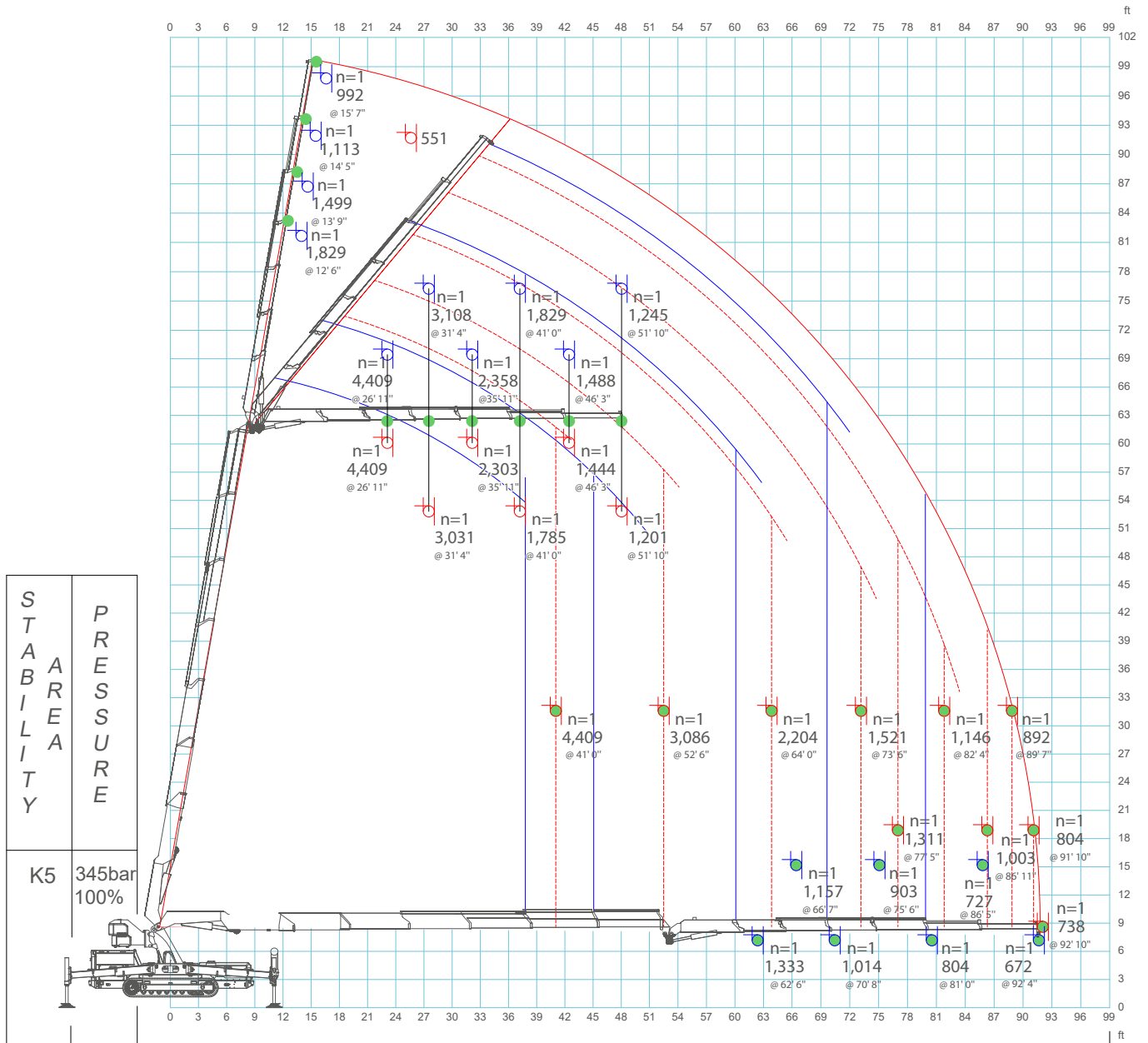

- Static lifting capacity: LMI stop position.
- Dynamic lifting capacity: all crane function are possible.

JF545 - MWP-1PG.JIB3000.6H

Man Working Platform for 1 Worker

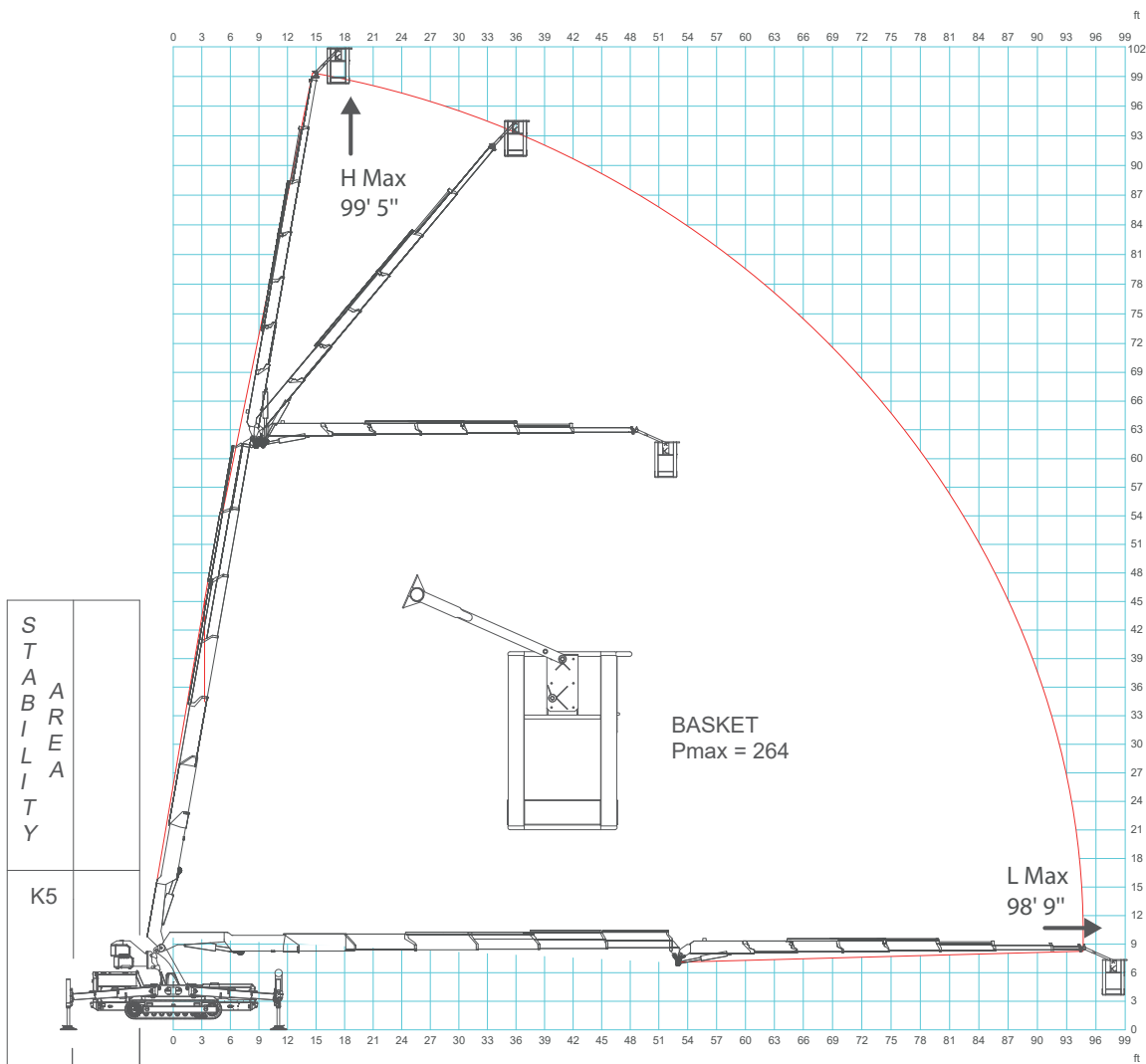

JF545 - MWP-2PG.JIB3000.6H

Man Working Platform for 2 Workers

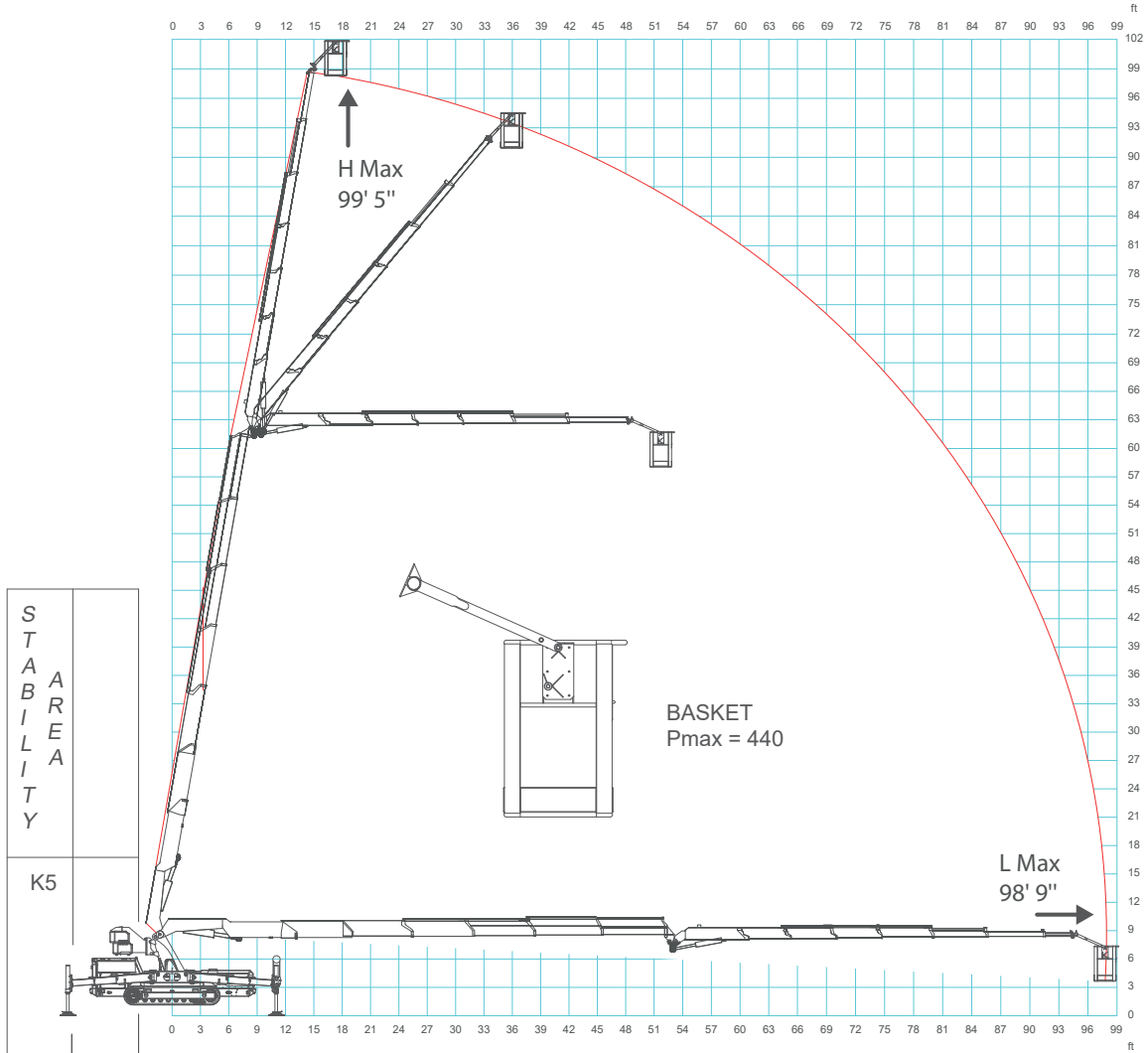

JF545 - MWP-2PGR.JIB3000.6H

Rotating Man Working Platform for 2 Workers

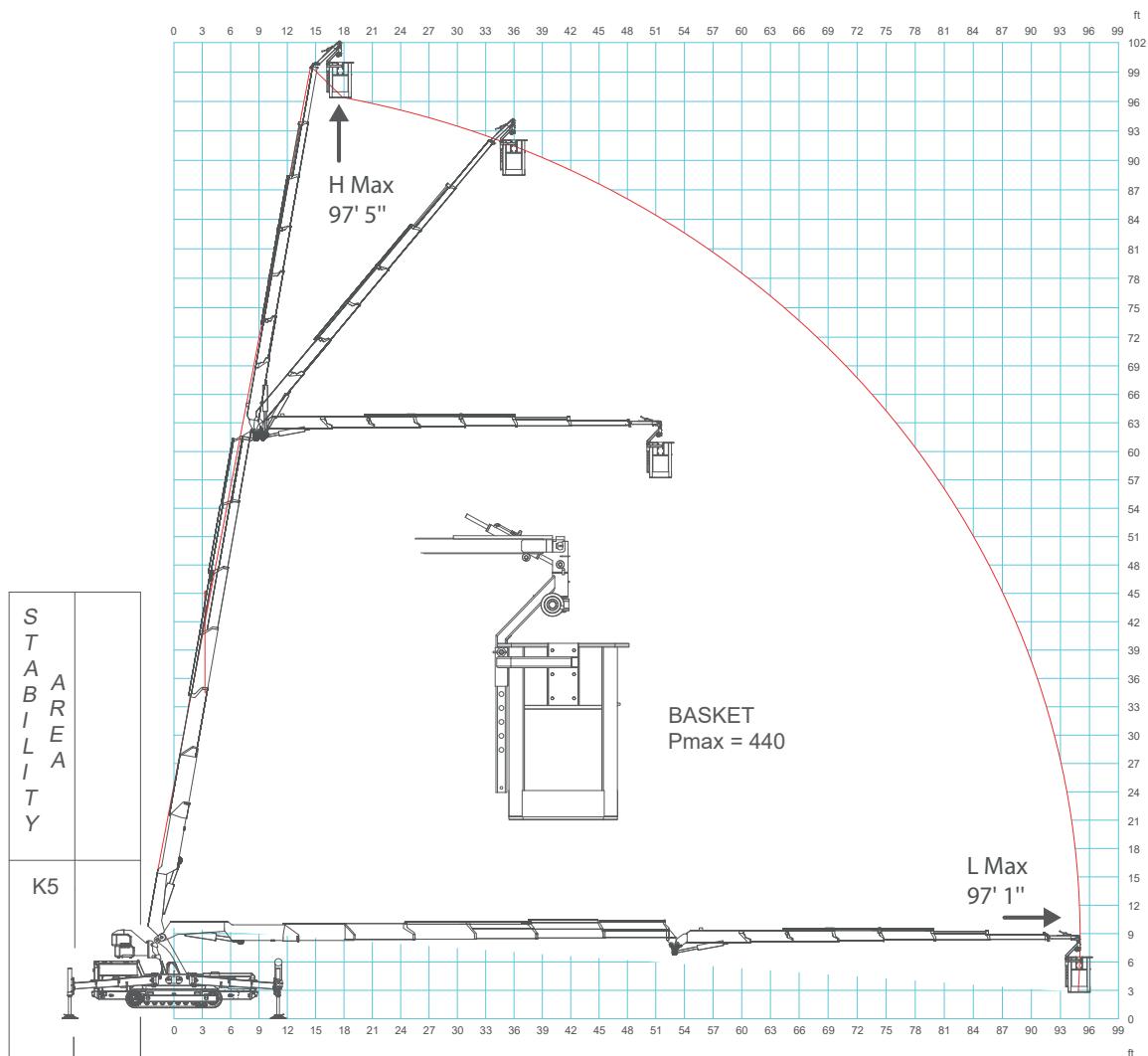

PLE STABILITY CONDITION

Maximum stability needs 8 conditions: 4 complete outriggers rotation and 4 complete outriggers extension. Every lack of condition induces a loss of working area. If more than one condition lack inhibit sectors are added.

Outrigger rotation is considered at its maximum when angle is $<43^\circ$.

Outrigger extension is considered at its maximum when is greater than 95%.

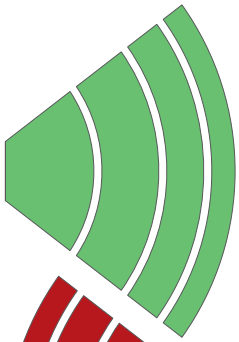

Permitted working area.

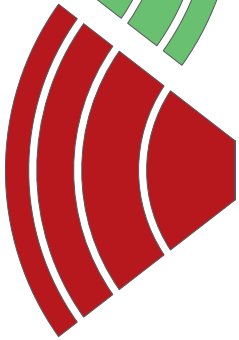

Not permitted working area.



Maximum stability:
Full rotation of the outriggers.
Full extensions of the outriggers.



If even a single outriggers is not on the ground no possible movement is permitted.

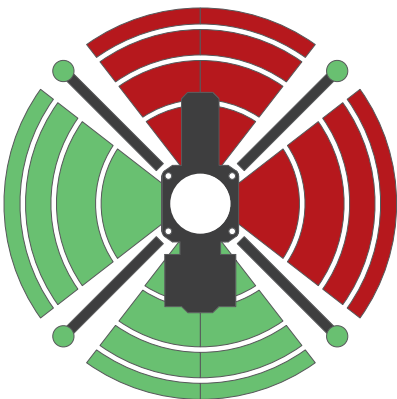

Outrigger 1 not fully extended but fully rotated.



Outrigger 1 fully extended but not fully rotated.

ACCESSORIES FEATURES

MEH-JF545.6

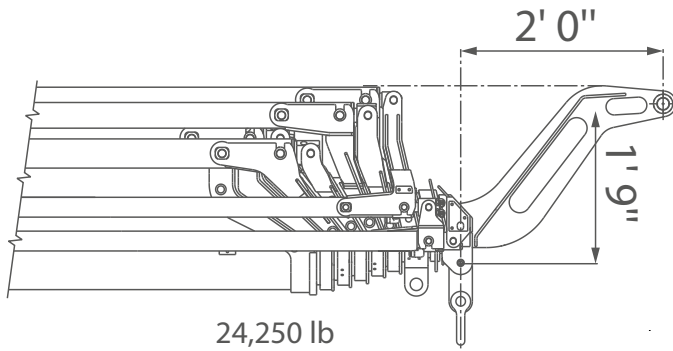

MEH-JIB3000.6HA

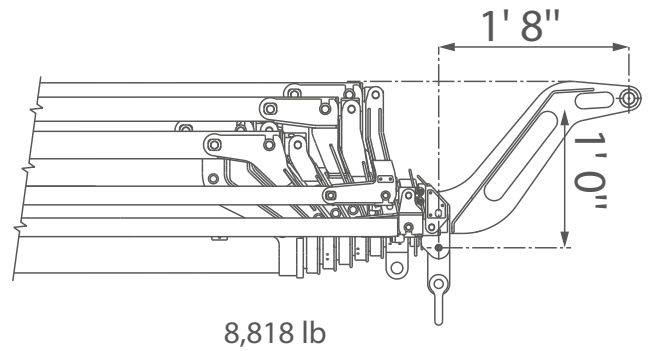

JIB3000.6HA

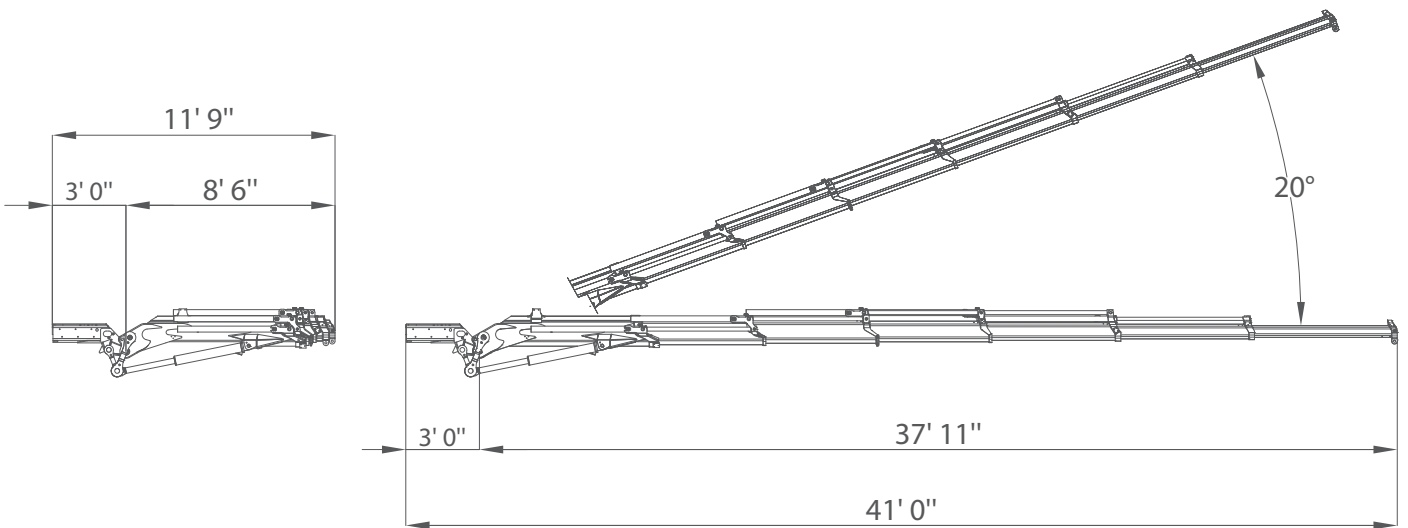

WTP-JFM

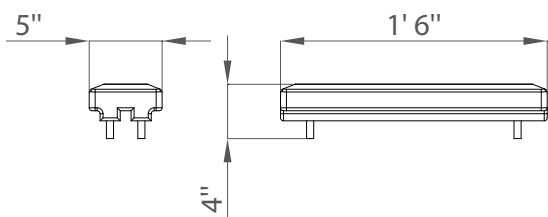

2MF-CL

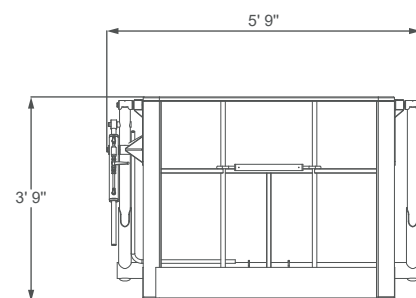
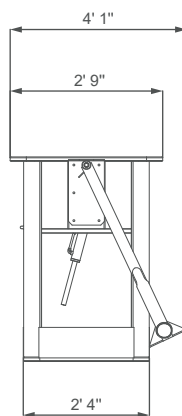



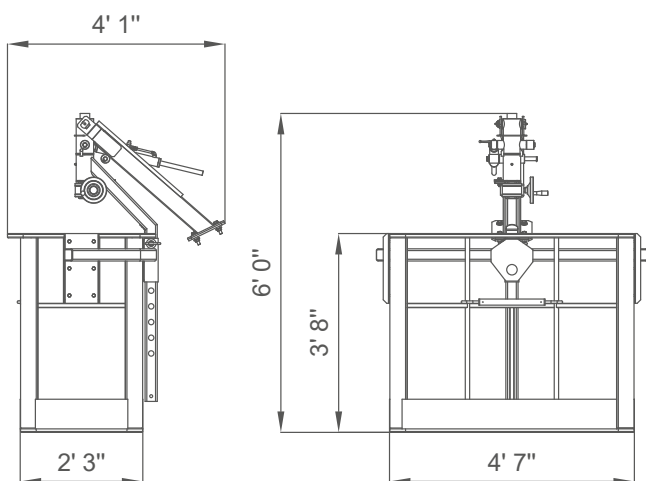



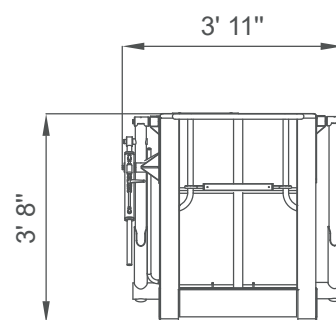
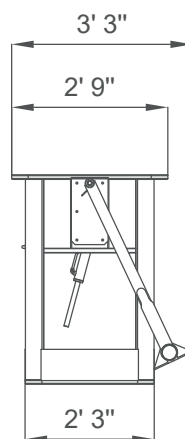











2MF-RCL



1MF-CL



SYMBOLS

	Counterweight		Engine		Boom Angle		Hydraulic Oil
	Crane		Diesel Fuel		Boom Length		Powerpack
	Travel Speed		Tank		Jib		Outriggers Mats
	Gradeability		Power		Main Winch		Slewing
	Track Loading		Outrigger Load		Hook Block		

REMARKS REFERRING TO LOAD CHART

- HC1 HD5 S2 lifting class according to EN12999:2011 standards.
- Lifting capacities are given in kilograms.
- The weight of the hook blocks and hooks is part of the load and therefore it must be deducted from the lifting capacities.
- Working radii are measured from the slewing centre.
- The lifting capacities given for the telescopic boom apply if the folding jib is removed.
- Subject to modification of lifting capacities.

**YOUR
JEKKO
DEALER**

EN All specifications and features herein described can be changed without prior advice. All indicated data are indicative only and are not binding as crane performs differently depending on its use. **IT** Tutte le caratteristiche e le specifiche descritte possono essere soggette a variazioni senza preavviso. Tutti i dati riportati sono forniti a puro titolo informativo e non sono impegnativi dal momento che le prestazioni della macchina variano in funzione dell'utilizzo. **DE** Unangekündigte Änderungen sämtlicher Eigenschaften und Daten sind möglich. Alle Angaben sind Richtwerte und nicht verbindlich da die Leistungen der Vorrichtung von deren Einsatz abhängen. **ES** Todas las características y las especificaciones aquí indicadas pueden ser sujetas a variaciones sin aviso. Se dan todos los datos aquí indicados como simples informaciones. No se consideran como vinculantes, dado que las prestaciones del maquinario pueden variar. **FR** Toutes les caractéristiques et le spécifications descriptives peut être sujet à variation sans préavis. Tout les données rapportés sont fournis à titre informatif et ne sont pas engager au moment que la prestation de la machine change en fonction de l'emploi.



www.jekko-cranes.com

Visit jekko-cranes.com to keep in contact with us, discover all the latest news and find out technical details of all our products.

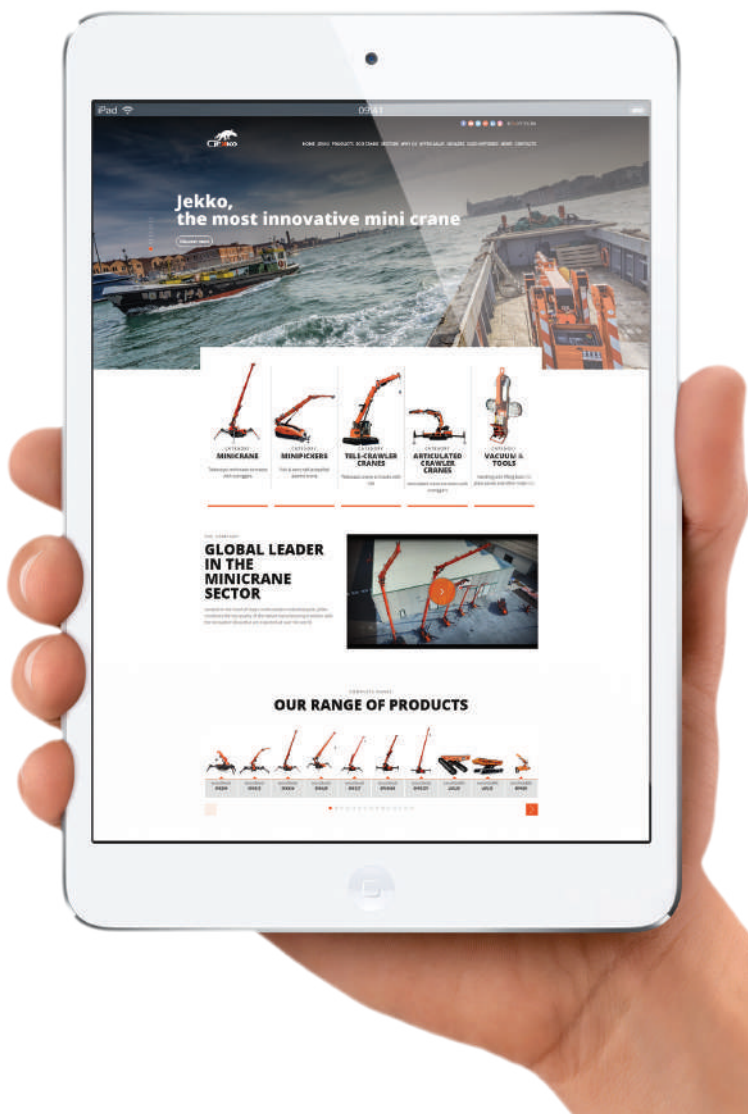



Jekko s.r.l.

Via Campardone, 1 - 31014 Colle Umberto (TV) - Italy
info@jekko.it - www.jekko-cranes.com

07.02.2023 | Rev.12

SERIAL NUMBER: