

Technical Data

Specifications & Capacities

TCC 550

Telescopic Crawler Crane
55 US ton
51 metric ton



CAUTION: This material is supplied for reference use only. Operator must refer to in-cab Crane Rating Manual and Operator's Manual to determine allowable crane lifting capacities and assembly and operating procedures.

Table Of Contents

| | |
|---|-----------|
| Upper Structure | 1 |
| Frame | 1 |
| Engine | 1 |
| Hydraulic System | 1 |
| Load Hoist Drums | 1 |
| Swing System | 1 |
| Counterweight | 1 |
| Operator's Cab | 1 |
| Rated Capacity Limiter System | 2 |
| Machinery House | 2 |
| Catwalks | 2 |
| Optional Vandal Guards | 2 |
| Lower Structure | 2 |
| Carbody | 2 |
| Side Frames | 2 |
| Travel and Steering | 2 |
| Tool Boxes | 2 |
| Boom | 3 |
| Design | 3 |
| Boom | 3 |
| Boom Head | 3 |
| Boom Elevation | 3 |
| Auxiliary Lifting Sheave | 3 |
| Optional Equipment | 3 |
| Hook Blocks And Balls | 3 |
| Fly & Attachments | 3 |
| Dimensions | 4 |
| Base Crane | 4 |
| Auxiliary Lifting Sheave | 6 |
| Fly | 6 |
| Counterweights | 7 |
| Optional XL Counterweight | 7 |
| Hookballs | 8 |
| Hook Blocks | 8 |
| Working Weights | 9 |
| Transport Drawing | 9 |
| Load Hoist Performance | 9 |
| Working Areas | 10 |
| Boom Extend Modes | 10 |
| Attachments | 11 |
| Main Boom Working Range Diagrams | 12 |
| Main Boom Load Charts | 13 |
| Main Boom Load Charts (Metric) | 15 |
| Main Boom + Fly Load Charts | 17 |
| Main Boom + Fly Load Charts (Metric) | 19 |

Upper Structure

Frame

All welded steel frame with precision machined surfaces for mating parts.

Turntable Bearing

- Inner race is bolted to upper frame
- Outer race with external swing gear is bolted to lower frame

Engine

Engine

Full pressure lubrication, oil filter, air cleaner, hour meter, throttle, and electric control shutdown.

| Specification | Cummins QSB |
|---|-------------------------|
| | Tier 4f (Stage IV) |
| Numbers of Cylinders | 6 |
| Cycle | 4 |
| Bore & Stroke: inch (mm) | 4.21 x 4.88 (107 x 124) |
| Piston Displacement: in ³ (L) | 409 (6.7) |
| Max. Brake Horsepower: hp (kW) | 215 (160) @ 1,800 rpm |
| Peak Torque: ft lb (Nm) | 700 (949) @ 1,500 rpm |
| Alternator: volt – amps | 12 – 150 |
| Crankcase Capacity: qt (L) | 19 (18) |
| <ul style="list-style-type: none"> • Engine driven variable speed viscus fan clutch and thermostatically controlled radiator | |

Fuel Tank

One 80 gal (303L) capacity fuel tank.

Hydraulic System

Hydraulic Pumps

The pump arrangement is designed to provide hydraulically powered functions allowing positive, precise control with independent or simultaneous operation of all crane functions.

- Two variable displacement pumps provide independent control for hoist drums, boom hoist, boom extend, and right & left travel.
- Two gear type pumps are used for the swing, retract cylinders & operator's controls, and hydraulic oil cooling fan.

Hydraulic Reservoir

133 gal (504L) capacity equipped with sight level gauge. Diffusers built in for deaeration.

Filtration

One 10 micron, full flow return line filter. Accessible for easy filter replacement.

Counterbalance Valves

All hoist motors are equipped with counterbalance valves to provide positive load lowering and prevent accidental load drop if the hydraulic pressure is suddenly lost.

Load Hoist Drums

Main and Optional Auxiliary Winches

- Axial piston, full and half displacement (2–speed) motor driven through planetary reduction unit for positive control under all load conditions.
- Grooved lagging
- Power up/down mode of operation
- Hoist drum cable follower – optional
- Drum rotation indicator
- Drum diameter: 10.63 in (27cm)
- Rope length:
 - Main: 550 ft (182.9m)
 - Auxiliary: 450 ft (137.2m) or 500 ft (182.9m)
- Maximum rope storage: 737 ft (224.6m)
- Terminator style socket and wedge

Third Wrap Indicator – Optional – Visually and audibly warns the operator when the wire rope is on the first/bottom layer and when the wire rope is down to the last three wraps.

Swing System

Motor/Planetary – Bi-directional hydraulic swing motor mounted to a planetary reducer for 360° continuous smooth swing at 2.0 rpm

Swing Park Brake – 360°, electric over hydraulic, (spring applied/hydraulic released) multi-disc brake mounted on the speed reducer. Operated by a switch in the operator's cab.

Swing Brake – 360°, foot operated, hydraulic swing valve regulates flow to the swing motor acting as a service brake

House Lock – Two-position house lock (boom over front or rear) operated from the operator's cab

Counterweight

Consists of a five piece design.

- One "A" counterweight, 12,000 lb (5.4mt)
- One "B" counterweight, 13,000 lb (5.8mt)
- Optional one "C" counterweight, 5,000 lb (2.6mt)
- Optional two "A" carbody counterweights, 3,000 lb (1.3mt) each with tool box built in

Operator's Cab

Fully enclosed modular steel compartment is independently mounted and padded to protect against vibration and noise.

- All tinted/tempered safety glass
- Sliding entry door and front and rear window
- Swing up roof window with windshield wiper
- Door and window locks
- Hot water heater
- Air conditioner
- Sun visor
- Cloth seat
- Circulating fan
- Windshield wipers and washer
- Dry chemical fire extinguisher
- Engine instrumentation panel (tachometer, voltmeter, engine oil pressure, engine water temperature, fuel level, hydraulic oil temperature, hour meter, and service monitor system)
- Mechanical drum rotation indicators for main (rear) and auxiliary (front) hoist drums
- Six way adjustable seat
- Foot throttle
- Joystick controls
- Bubble type level
- Ergonomic gauge layout
- Controls shut off lever
- AM/FM Radio
- Travel levers & pedals
- Camera (winch, rear view, & right side)
- Fully adjustable single axis controls – optional

Rated Capacity Limiter System

Link–Belt Pulse – The Link–Belt in–house designed, total crane operating system that utilizes the display as a readout and operator interface for the following systems:

- Crane configuration
- Boom length
- Boom head height
- Allowed load and % of allowed load
- Data logging
- Boom angle
- Radius of load
- Actual load

- Operator settable alarms (include):
 - Maximum and minimum boom angles
 - Maximum tip height
 - Maximum boom length
 - Swing left/right positions
 - Operator defined area (imaginary plane)

Telematics – Cellular–based data logging and monitoring system that provides:

- Location and operational settings
- Routine maintenance
- Crane and engine monitoring
- Diagnostic and fault codes

Machinery House

- Hinged doors (four on right side) for machinery access
- Textured paint finish

Catwalks

Standard on right and left sides. Catwalks fold up and pin for reduced travel width.

Optional Vandal Guards

Under design

Lower Structure

Carbody

Lower Frame

All welded box construction frame with precision machined surfaces for turntable bearing and rotating joint.

Side Frames

Side Frames

All welded, precision machined, steel frames can be hydraulically extended and retracted with a hydraulic cylinder mounted in the lower frame.

- 12 ft 6.9 in (3.8m) extended gauge
- 10 ft 10.6 in (3.3m) intermediate gauge
- 8 ft 9.8 in (2.7m) retracted gauge
- 19 ft 6.2 in (5.9m) overall length
- 31.5 in (0.80m) wide track shoes
- Sealed (oil filled) idler and drive planetaries
- Compact travel drives
- Hydraulic self adjusting tracks

Track Rollers

- Eleven sealed (oil filled) track rollers per side frame and 3 (oil filled) upper track roller.
- Heat treated, mounted on anti–friction bearings

Tracks

Heat treated, self–cleaning grouser shoes and heat treated track pins with dirt seals. 61 track shoes per side.

- Optional flat or “street” pad

Take Up Idlers

Cast steel, heat treated, self–cleaning, mounted on sealed tapered roller bearings

Travel and Steering

Each side frame contains a pilot controlled, bi–directional, axial piston motor and a planetary gear reduction unit to provide positive control under all load conditions.

- 2–speed travel
- Individual control provides smooth, precise maneuverability including full counter–rotation.
- Spring applied, hydraulically released multiple wet–disc type brake controlled automatically
- Maximum travel speed is 2 mph (3.2km/h).
- Designed to 40% gradeability

Tool Boxes

Integrated into carbody counterweights.

Boom

Design

Four section, greaseless formed boom with Teflon wear pads constructed of high tensile steel consisting of one base section and three telescoping sections. The first telescoping section extends independently by means of one double-acting, single stage hydraulic cylinder with integrated holding valves. The second and third telescoping sections extend proportionally by means of one double-acting, single stage cylinder with integrated holding valves and cables.

Boom

- 36 ft 8 in—115 ft (11.2—35.05m) four section full power boom
- Two mode boom extensions: In mode EM1, the T1, T2, and T3 sections extend and retract synchronously to a maximum of 115.0' boom length. In mode EM2, only the T1 section extends to reach a 62.8' boom length. The T2 and T3 sections do not extend and will stay retracted inside the T1 section.
- Mechanical boom angle indicator
- Maximum tip height for EM2 mode is 69 ft (21.1m) and EM1 is 120 ft (36.7m).

Boom Head

- Four 16.5 in (41.9cm) root diameter sealed bearing nylon sheaves to handle up to eight parts of line
- Easily removable wire rope guards
- Rope dead end lugs on each side of the boom head
- Boom head is designed for quick-reeve of the hook block

Boom Elevation

- One double acting hydraulic cylinder with integral holding valve
- Boom elevation: -3° to 78°

Auxiliary Lifting Sheave

- Single 16.5 in (41.9cm) root diameter nylon sheave
- Easily removable wire rope guard
- Does not affect erection of the fly or use of the main head sheaves

Optional Equipment

Hook Blocks And Balls

- 41 ton (37mt) 3 sheave quick-reeve hook block with safety latch
- 60 ton (55mt) 5 sheave quick-reeve hook block with safety latch
- 8.0 ton (7.25mt) swivel hook ball with safety latch

Fly & Attachments

- 28.5—51 ft (8.7—15.6m) two piece bi-fold lattice fly, stowable, offsettable to 2° , 20° , and 40° . Maximum tip height is 172 ft (52.4m).

Dimensions

Base Crane

| General Dimensions | English | Metric |
|---------------------|-------------|------------|
| Basic Boom | 36.8-115 ft | 11.2-35.5m |
| Minimum Load Radius | 9 ft | 2.5m |
| Maximum Boom Angle | 78° | 78° |
| Track Shoe Width | 32 in | 0.81m |

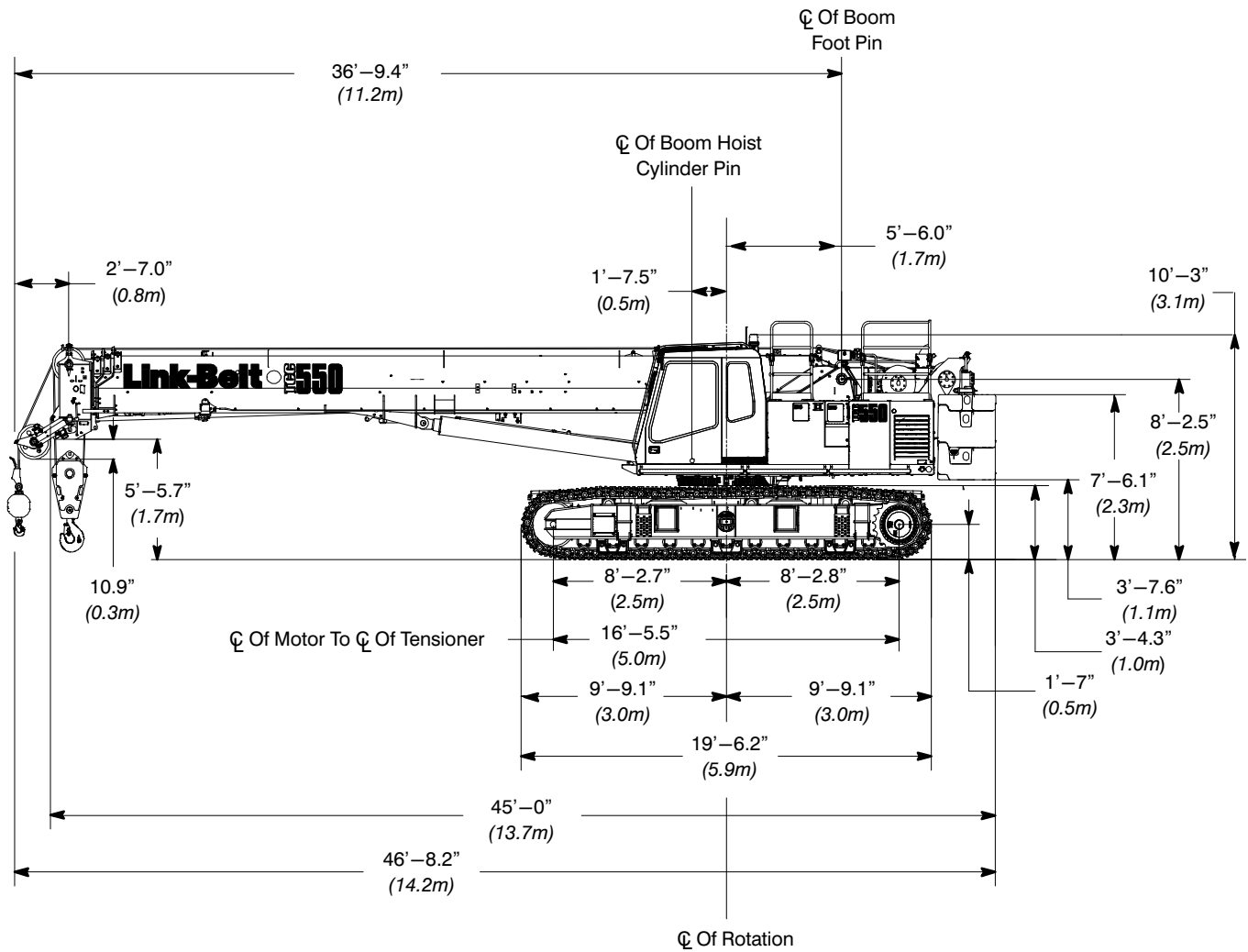

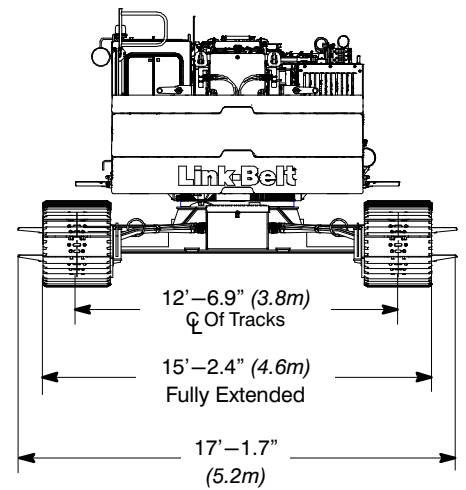
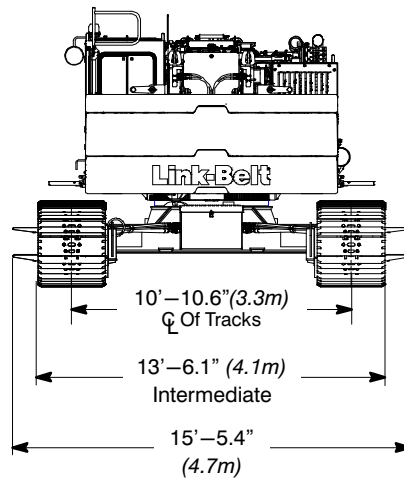
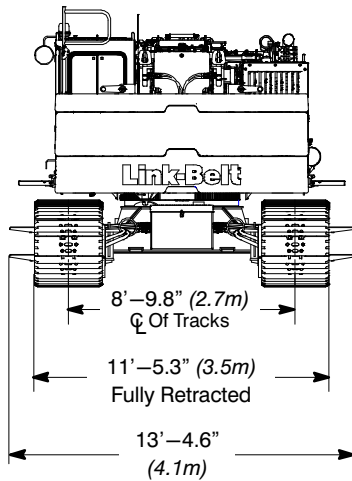
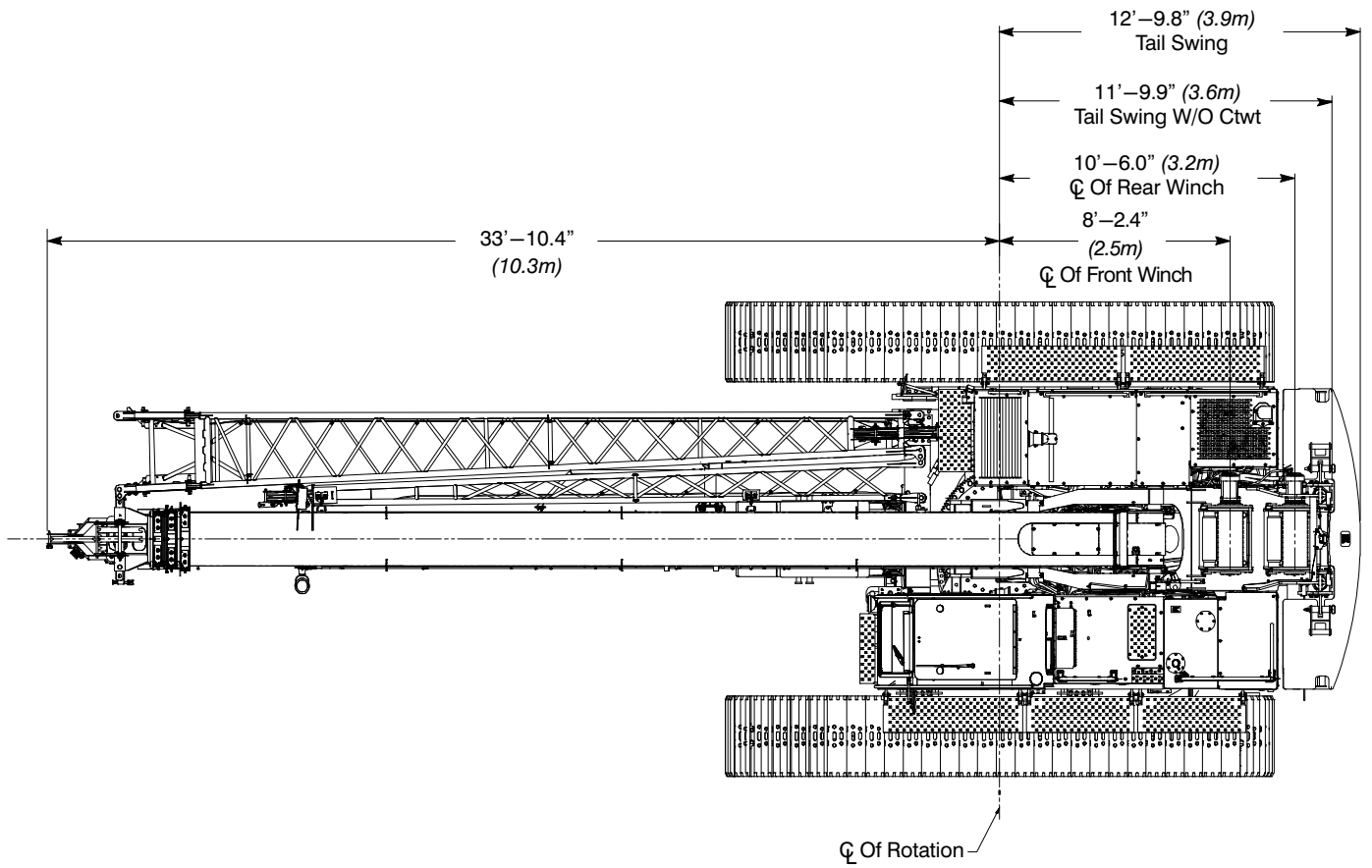

Auxiliary Lifting Sheave

Auxiliary Lifting Sheave ①

| | | |
|--------|----------|---------|
| Length | 35.31 in | (0.90m) |
| Width | 16.31 in | (0.41m) |
| Height | 19 in | (0.48m) |
| Weight | 92.5 lb | (42kg) |

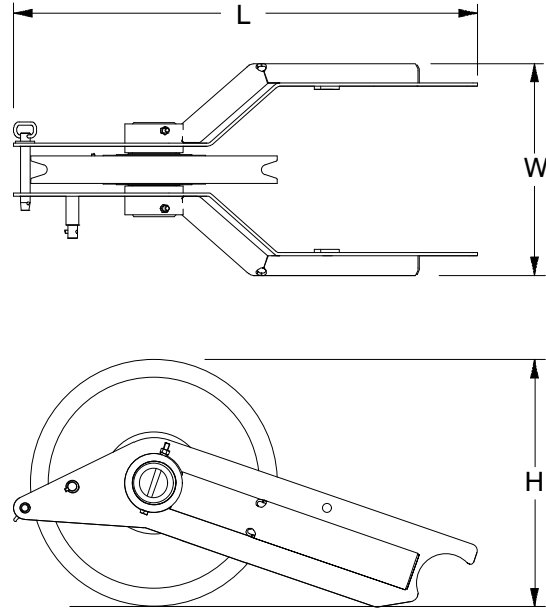

Fly

28.5 ft (8.69m) Offset Fly One Piece Lattice Fly (Base Fly) ①

| | | |
|--------|----------|---------|
| Length | 28.5 ft | (8.69m) |
| Width | 29 in | (0.74m) |
| Height | 30 in | (0.76m) |
| Weight | 1,188 lb | (539kg) |

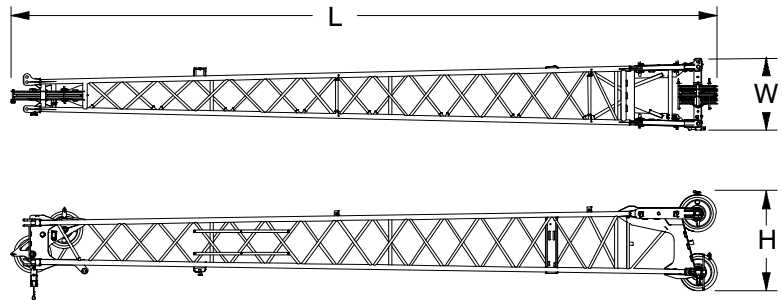

22.5 ft (6.86m) Lattice Fly Tip (Addition To Base Fly For 28.5-51 ft (8.69-15.55m) Bi-fold Fly) ①

| | | |
|--------|----------|---------|
| Length | 22.5 ft | (6.86m) |
| Width | 13.78 in | (0.35m) |
| Height | 20 in | (0.51m) |
| Weight | 654 lb | (297kg) |

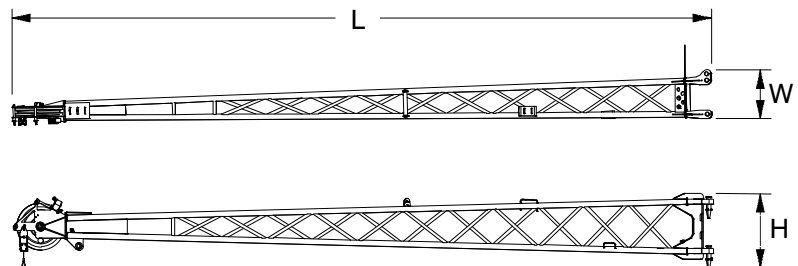

Number inside black circle "①" = # of components

* - Optional equipment

Counterweights

"A" Counterweight ①

| | | |
|--------|--------------|---------|
| Length | 32.90 in | (0.84m) |
| Width | 9 ft 10 in | (3.00m) |
| Height | 4 ft 2.18 in | (1.28m) |
| Weight | 12,000 lb | (5.4mt) |

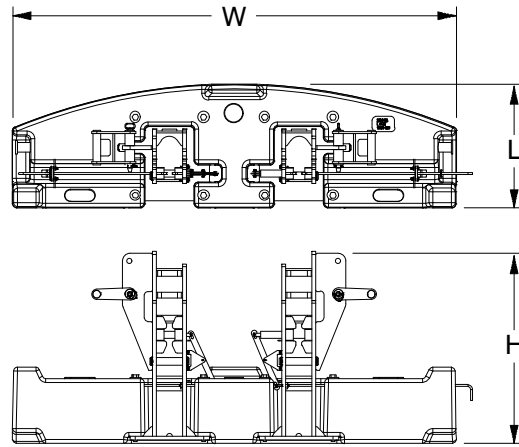

"B" Counterweight ①

| | | |
|--------|------------|---------|
| Length | 32.90 in | (0.84m) |
| Width | 9 ft 10 in | (3.00m) |
| Height | 23 in | (0.58m) |
| Weight | 13,000 lb | (5.8mt) |

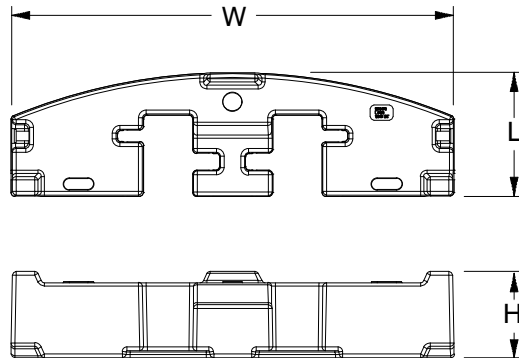

Optional XL Counterweight

Optional "C" Counterweight ①

| | | |
|--------|------------|---------|
| Length | 32.90 in | (0.84m) |
| Width | 9 ft 10 in | (3.00m) |
| Height | 8.50 in | (0.22m) |
| Weight | 5,000 lb | (2.2mt) |

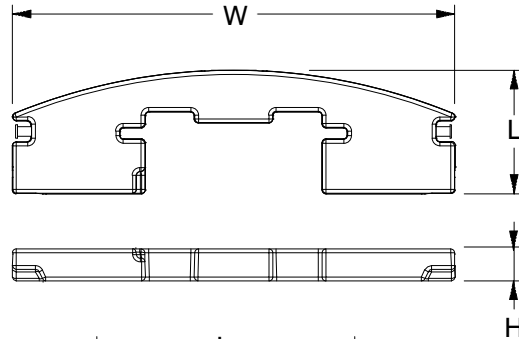

Optional "A" Carbody Counterweights ②

| | | |
|--------|----------|---------|
| Length | 62.50 in | (1.59m) |
| Width | 30 in | (0.76m) |
| Height | 20.12 in | (0.51m) |
| Weight | 3,000 lb | (1.3mt) |

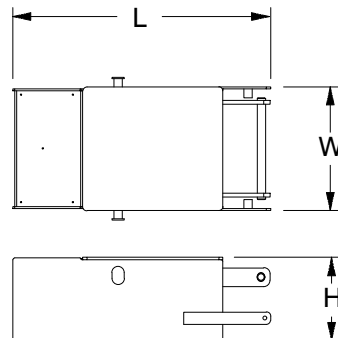

Number inside black circle "①" = # of components
 * – Optional equipment

Hookballs

8.0 Ton (7.25mt) Swivel

Hook Ball* 1

| | | |
|--------|----------|---------|
| Width | 13.56 in | (0.34m) |
| Height | 28.94 in | (0.74m) |
| Weight | 320 lb | (145kg) |

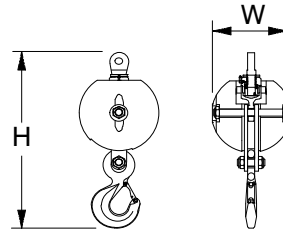

Hook Blocks

41 Ton (37mt)

3-Sheave Hook Block* 1

| | | |
|--------|----------|---------|
| Width1 | 10.13 in | (0.27m) |
| Width2 | 19.69 in | (0.50m) |
| Height | 56.5 in | (1.44m) |
| Weight | 843 lb | (378kg) |

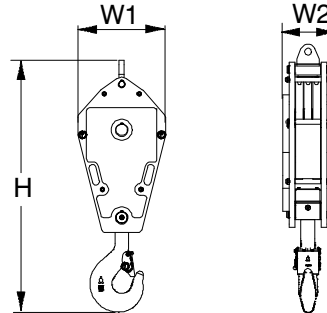

60 Ton (55mt)

5-Sheave Hook Block* 1

| | | |
|--------|----------|---------|
| Width1 | 14.65 in | (0.37m) |
| Width2 | 19.69 in | (0.50m) |
| Height | 55.03 in | (1.40m) |
| Weight | 1,096 lb | (497kg) |

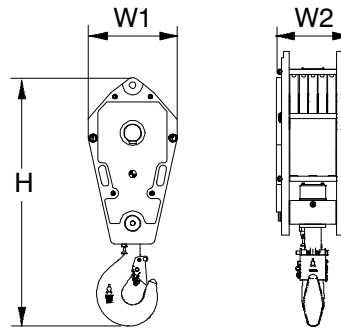

Number inside black circle 1 = # of components

* – Optional equipment

Working Weights

| Option | Description | Gross Weight lb (kg) | Ground Bearing Pressure (on soft ground) psi (kg/cm ²) |
|--------|---|-------------------------|--|
| 1 | Base crane, "AB" counterweight, 550 ft (182.9m) type "KC" main wire rope, 450 ft (137.2m) type "KC" auxiliary wire rope, 2-piece fly, 41 ton (36.29mt) 3 sheave hook block, 8.0 ton (7.3mt) hook ball, and a 250 lb (113kg) operator. | 99,850 (45 291kg) | 8.57 (0.60) |
| 2 | Base crane, "ABC+A" counterweight, lower toolbox, 550 ft (182.9m) type "KC" main wire rope, 450 ft (137.2m) type "KC" auxiliary wire rope, 2-piece fly, 40 ton (36.29mt) 3 sheave hook block, 8 ton (7.3mt) hook ball, and a 250 lb (113kg) operator. | 109,850 (49 827kg) | 8.57 (0.60) |

Notes: Ground bearing pressure is based on the total weight distributed evenly over the track contact area.

Transport Drawing

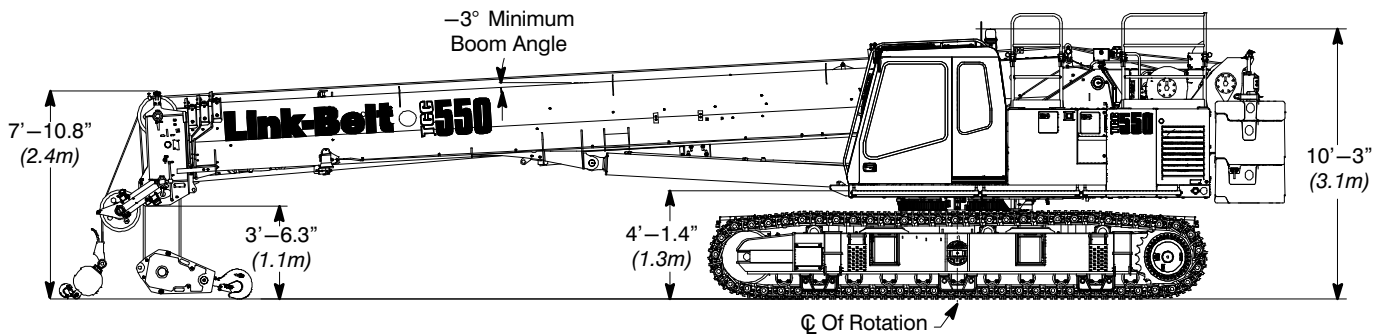

Transport Weight – 99,850 lb (45 291kg)

Base crane, "AB" Counterweight, 550 ft (182.9m) type "KC" main wire rope, 450 ft (137.2m) type "KC" auxiliary wire rope, 2-piece fly, 41 ton (36.29mt) 3 sheave hook block, and 8 ton ball

Load Hoist Performance

| Main (Rear) and Auxiliary (Front) Winches – 5/8 in (16mm) Rope | | | | | | | | | | |
|--|-------------------|---------|-------------------|-------|-----------------|-------|-------|------|-------|-------|
| Layer | Maximum Line Pull | | Normal Line Speed | | High Line Speed | | Layer | | Total | |
| | lb | kg | ft/min | m/min | ft/min | m/min | ft | m | ft | m |
| 1 | 17,084 | 7 749.1 | 181 | 55.2 | 360 | 109.6 | 97 | 29.6 | 97 | 29.6 |
| 2 | 15,454 | 7 009.8 | 200 | 61.1 | 398 | 121.2 | 107 | 32.6 | 205 | 62.4 |
| 3 | 14,107 | 6 398.8 | 219 | 66.9 | 436 | 132.8 | 118 | 35.9 | 322 | 98.3 |
| 4 | 12,977 | 5 886.2 | 239 | 72.7 | 474 | 144.3 | 128 | 39.0 | 451 | 137.3 |
| 5 | 12,014 | 5 449.4 | 258 | 78.6 | 511 | 155.9 | 138 | 42.1 | 589 | 179.5 |
| 6 | 11,184 | 5 072.9 | 277 | 84.4 | 549 | 167.5 | 149 | 45.3 | 737 | 224.7 |

| Wire Rope Application | | Diameter | | Type | Maximum Permissible Load | |
|-----------------------|----------|----------|----|---|--------------------------|-------|
| | | in | mm | | lb | kg |
| Main (Rear) Winch | Standard | 5/8 | 16 | 37x7 galvanized rotation resistant – right lang lay (Type KC) 35x7 rotation resistant – right lang lay (Type CC) | 10,835 | 4 914 |
| | Optional | 5/8 | 16 | | 12,240 | 5 552 |

Working Areas

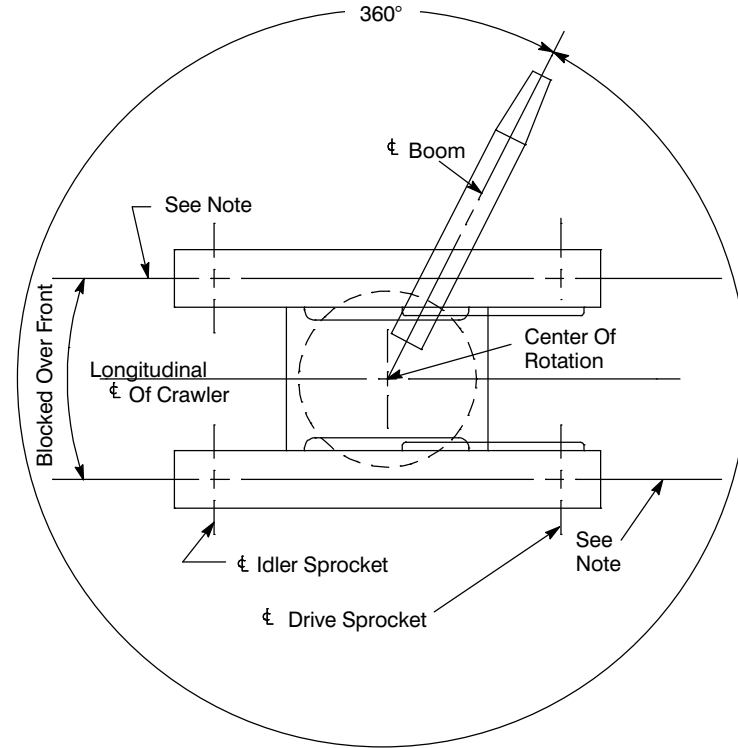

Note: These Lines Determine The Limiting Position Of Any Load For Operation Within Working Areas Indicated.

Boom Extend Modes

| Boom Length | | Boom Mode | | |
|-------------|-------|-----------|------|------|
| ft | m | T3 | T2 | T1 |
| 36.8 | 11.20 | | | |
| 45 | 13.72 | 11% | 11% | 11% |
| 55 | 16.76 | 23% | 23% | 23% |
| 65 | 19.81 | 36% | 36% | 36% |
| 75 | 22.86 | 49% | 49% | 49% |
| 85 | 25.91 | 62% | 62% | 62% |
| 95 | 28.96 | 74% | 74% | 74% |
| 105 | 32.00 | 87% | 87% | 87% |
| 115 | 35.05 | 100% | 100% | 100% |

EM 1

| Boom Length | | Boom Mode | | |
|-------------|-------|-----------|----|------|
| ft | m | T3 | T2 | T1 |
| 36.8 | 11.20 | | | |
| 45 | 13.72 | | | 32% |
| 55 | 16.76 | | | 70% |
| 62.83 | 19.15 | | | 100% |

EM 2

Attachments

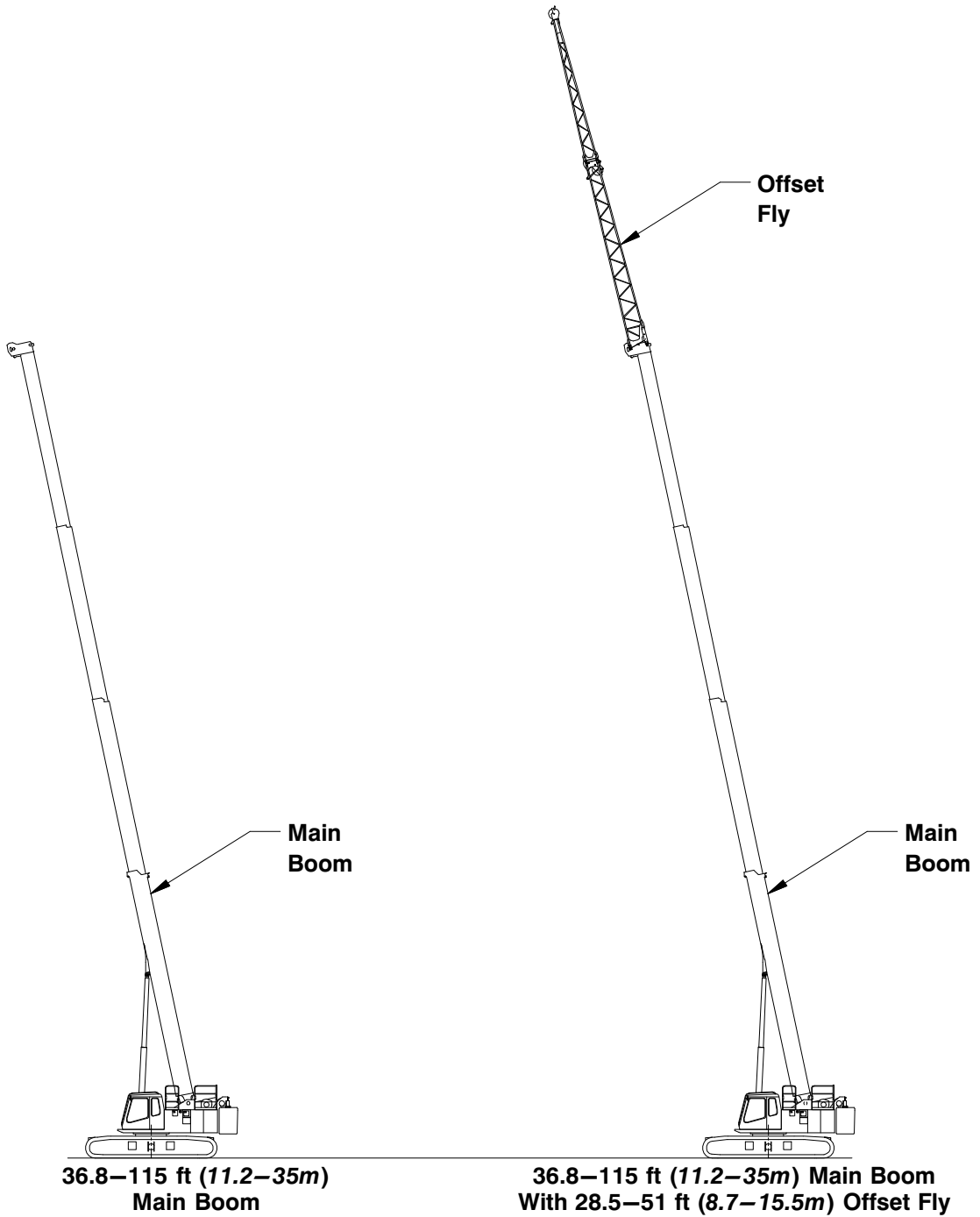

Main Boom Working Range Diagrams

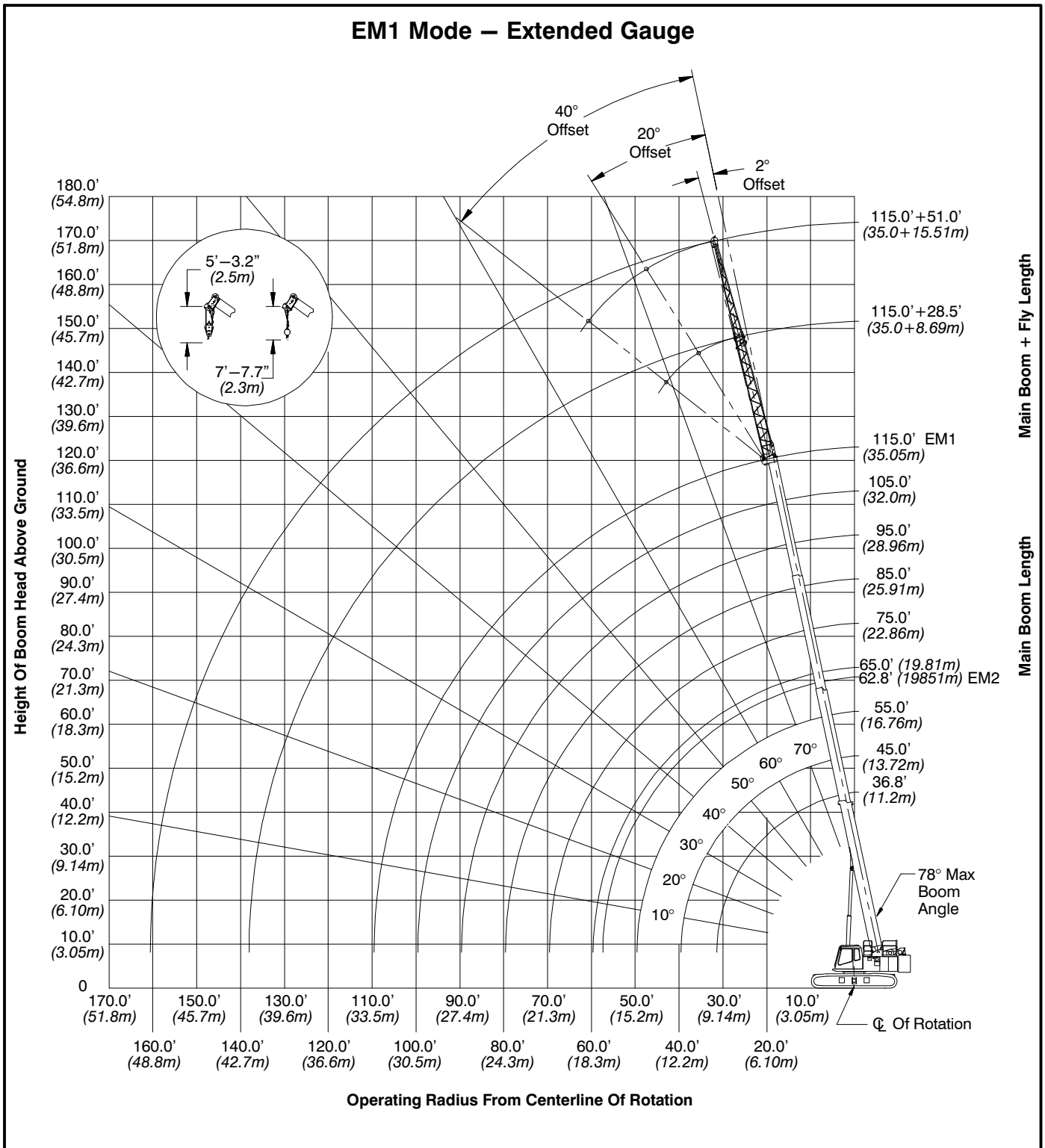

Main Boom Load Charts

| Main Boom Lift Capacity Chart – 360° Rotation – Side Frames Extended Position AB+0 [25,000 lb] Counterweight [All capacities are listed in kips] | | | | | | | | | | |
|--|------------------|------|------|---------|------|------|------|------|------|------------------|
| Load Radius (ft) | Boom Length (ft) | | | | | | | | | Load Radius (ft) |
| | 36.8 | 45 | 55 | 62.8–65 | 75 | 85 | 95 | 105 | 115 | |
| 9 | 110.0 | | | | | | | | | 9 |
| 10 | 102.2 | 83.3 | 81.9 | | | | | | | 10 |
| 12 | 91.5 | 83.3 | 81.4 | 68.2 | | | | | | 12 |
| 15 | 74.0 | 73.4 | 70.5 | 60.7 | 39.2 | | | | | 15 |
| 20 | 44.5 | 44.2 | 43.8 | 43.6 | 39.2 | 37.1 | | | | 20 |
| 25 | 30.7 | 31.4 | 31.9 | 32.1 | 32.2 | 32.1 | 28.6 | 26.1 | | 25 |
| 30 | 22.6 | 23.3 | 23.8 | 24.1 | 24.2 | 24.3 | 24.4 | 22.9 | 20.8 | 30 |
| 35 | | 18.1 | 18.6 | 18.9 | 19.1 | 19.2 | 19.3 | 19.3 | 18.8 | 35 |
| 40 | | | 14.9 | 15.2 | 15.4 | 15.5 | 15.6 | 15.7 | 15.7 | 40 |
| 45 | | | 12.1 | 12.4 | 12.6 | 12.8 | 12.9 | 12.9 | 13.0 | 45 |
| 50 | | | | 10.3 | 10.5 | 10.7 | 10.8 | 10.8 | 10.9 | 50 |
| 55 | | | | 8.6 | 8.8 | 9.0 | 9.1 | 9.2 | 9.3 | 55 |
| 60 | | | | | 7.5 | 7.6 | 7.8 | 7.8 | 7.9 | 60 |
| 65 | | | | | 6.3 | 6.5 | 6.6 | 6.7 | 6.8 | 65 |
| 70 | | | | | | 5.5 | 5.6 | 5.7 | 5.8 | 70 |
| 75 | | | | | | 4.7 | 4.8 | 4.9 | 5.0 | 75 |
| 80 | | | | | | | 4.1 | 4.2 | 4.3 | 80 |
| 85 | | | | | | | 3.5 | 3.6 | 3.6 | 85 |
| 90 | | | | | | | | 3.0 | 3.1 | 90 |
| 95 | | | | | | | | 2.5 | 2.6 | 95 |
| 100 | | | | | | | | | 2.2 | 100 |
| 105 | | | | | | | | | 1.8 | 105 |

This material is supplied for reference use only. Operator must refer to in-cab Crane Rating Manual and Operator's Manual to determine allowable crane lifting capacities and assembly and operating procedures.

Main Boom Lift Capacity Chart — 360° Rotation — Side Frames Extended Position
ABC+A [36,000 lb] Counterweight
 [All capacities are listed in kips]

| Load Radius (ft) | Boom Length (ft) | | | | | | | | | Load Radius (ft) |
|------------------|------------------|------|------|---------|------|------|------|------|------|------------------|
| | 36.8 | 45 | 55 | 62.8-65 | 75 | 85 | 95 | 105 | 115 | |
| 9 | 110.0 | | | | | | | | | 9 |
| 10 | 102.2 | 83.3 | 81.9 | | | | | | | 10 |
| 12 | 91.5 | 83.3 | 81.4 | 68.2 | | | | | | 12 |
| 15 | 79.0 | 75.4 | 70.5 | 60.7 | 39.2 | | | | | 15 |
| 20 | 51.4 | 51.2 | 50.8 | 50.5 | 39.2 | 37.1 | | | | 20 |
| 25 | 35.7 | 36.4 | 36.9 | 37.1 | 37.3 | 32.1 | 28.6 | 26.1 | | 25 |
| 30 | 26.6 | 27.3 | 27.8 | 28.1 | 28.3 | 28.2 | 25.2 | 22.9 | 20.8 | 30 |
| 35 | | 21.4 | 21.9 | 22.2 | 22.4 | 22.4 | 22.3 | 20.3 | 18.8 | 35 |
| 40 | | | 17.7 | 18.0 | 18.2 | 18.4 | 18.4 | 18.2 | 16.9 | 40 |
| 45 | | | 14.6 | 14.9 | 15.1 | 15.3 | 15.3 | 15.4 | 15.2 | 45 |
| 50 | | | | 12.5 | 12.7 | 12.8 | 12.9 | 13.0 | 13.0 | 50 |
| 55 | | | | 10.6 | 10.8 | 10.9 | 11.0 | 11.1 | 11.2 | 55 |
| 60 | | | | | 9.2 | 9.4 | 9.5 | 9.6 | 9.7 | 60 |
| 65 | | | | | 7.9 | 8.1 | 8.2 | 8.3 | 8.4 | 65 |
| 70 | | | | | | 7.0 | 7.1 | 7.2 | 7.3 | 70 |
| 75 | | | | | | 6.1 | 6.2 | 6.3 | 6.4 | 75 |
| 80 | | | | | | | 5.4 | 5.5 | 5.6 | 80 |
| 85 | | | | | | | 4.7 | 4.8 | 4.8 | 85 |
| 90 | | | | | | | | 4.2 | 4.2 | 90 |
| 95 | | | | | | | | 3.6 | 3.7 | 95 |
| 100 | | | | | | | | | 3.2 | 100 |
| 105 | | | | | | | | | 2.7 | 105 |

This material is supplied for reference use only. Operator must refer to in-cab Crane Rating Manual and Operator's Manual to determine allowable crane lifting capacities and assembly and operating procedures.

Main Boom + Fly Load Charts

| 115 ft Main Boom + Fly – 360° Rotation – Side Frames Extended Position AB+0 [25,000 lb] Counterweight [All capacities are listed in kips] | | | | | | | |
|---|----------------------------|------|-----|-------------------------|-----|-----|------------------|
| Load Radius (ft) | 28.25 ft Manual Offset Fly | | | 51 ft Manual Offset Fly | | | Load Radius (ft) |
| | 2° | 20° | 40° | 2° | 20° | 40° | |
| 35 | 11.1 | | | | | | 35 |
| 40 | 11.1 | | | | | | 40 |
| 45 | 11.1 | 11.9 | | 7.5 | | | 45 |
| 50 | 11.1 | 11.4 | | 7.5 | | | 50 |
| 55 | 9.6 | 1.03 | 8.8 | 7.5 | | | 55 |
| 60 | 8.2 | 8.9 | 8.6 | 7.5 | 6.2 | | 60 |
| 65 | 7.1 | 7.7 | 8.2 | 7.5 | 5.9 | | 65 |
| 70 | 3.1 | 6.6 | 7.1 | 6.5 | 5.6 | 4.0 | 70 |
| 75 | 5.3 | 5.8 | 6.2 | 5.7 | 5.4 | 3.8 | 75 |
| 80 | 4.6 | 5.0 | 5.4 | 4.9 | 5.2 | 3.7 | 80 |
| 85 | 4.0 | 4.4 | 4.7 | 4.3 | 4.9 | 3.6 | 85 |
| 90 | 3.4 | 3.8 | 4.0 | 3.8 | 4.4 | 3.5 | 90 |
| 95 | 2.9 | 3.3 | 3.5 | 3.3 | 3.8 | 3.4 | 95 |
| 100 | 2.5 | 2.8 | 3.0 | 2.8 | 3.4 | 3.4 | 100 |
| 105 | 2.1 | 2.4 | 2.5 | 2.4 | 2.9 | 3.3 | 105 |
| 110 | 1.8 | 2.0 | 2.1 | 2.1 | 2.5 | 2.9 | 110 |
| 115 | 1.5 | 1.6 | 1.7 | 1.8 | 2.2 | 2.5 | 115 |
| 120 | 1.2 | 1.3 | | 1.5 | 1.8 | 2.1 | 120 |
| 125 | 0.9 | 1.0 | | 1.2 | 1.5 | 1.8 | 125 |
| 130 | | | | 1.0 | 1.3 | 1.5 | 130 |
| 135 | | | | | 1.0 | 1.1 | 135 |
| 140 | | | | | | 0.9 | 140 |

This material is supplied for reference use only. Operator must refer to in-cab Crane Rating Manual and Operator's Manual to determine allowable crane lifting capacities and assembly and operating procedures.

**115' Main Boom + Fly – 360° Rotation – Side Frames Extended Position
ABC+A [36,000 lb] Counterweight
[All capacities are listed in kips]**

| Load Radius (ft) | 28.25 ft Manual Offset Fly | | | 51 ft Manual Offset Fly | | | Load Radius (ft) |
|------------------|----------------------------|------|-----|-------------------------|-----|-----|------------------|
| | 2° | 20° | 40° | 2° | 20° | 40° | |
| 35 | 11.1 | | | | | | 35 |
| 40 | 11.1 | | | | | | 40 |
| 45 | 11.1 | 11.9 | | 7.5 | | | 45 |
| 50 | 11.1 | 11.4 | | 7.5 | | | 50 |
| 55 | 11.1 | 11.0 | 8.8 | 7.5 | | | 55 |
| 60 | 10.0 | 10.0 | 8.6 | 7.5 | 6.2 | | 60 |
| 65 | 8.7 | 9.2 | 8.3 | 7.5 | 5.9 | | 65 |
| 70 | 7.6 | 8.1 | 8.1 | 7.5 | 5.6 | 4.0 | 70 |
| 75 | 6.7 | 7.2 | 7.6 | 7.0 | 5.4 | 3.8 | 75 |
| 80 | 5.9 | 6.3 | 6.7 | 6.2 | 5.2 | 3.7 | 80 |
| 85 | 5.2 | 5.6 | 5.9 | 5.5 | 4.9 | 3.6 | 85 |
| 90 | 4.6 | 4.9 | 5.2 | 4.9 | 4.7 | 3.5 | 90 |
| 95 | 4.0 | 4.3 | 4.6 | 4.3 | 4.5 | 3.4 | 95 |
| 100 | 3.5 | 3.8 | 4.0 | 3.8 | 4.4 | 3.4 | 100 |
| 105 | 3.1 | 3.3 | 3.5 | 3.4 | 3.9 | 3.3 | 105 |
| 110 | 2.7 | 2.9 | 3.0 | 3.0 | 3.4 | 3.2 | 110 |
| 115 | 2.3 | 2.5 | 2.6 | 2.6 | 3.0 | 3.2 | 115 |
| 120 | 2.0 | 2.2 | | 2.3 | 2.7 | 3.0 | 120 |
| 125 | 1.7 | 1.8 | | 2.0 | 2.3 | 2.6 | 125 |
| 130 | 1.4 | 1.5 | | 1.7 | 2.0 | 2.2 | 130 |
| 135 | 1.2 | | | 1.5 | 1.7 | 1.9 | 135 |
| 140 | | | | 1.3 | 1.5 | 1.6 | 140 |
| 145 | | | | 1.0 | 1.2 | | 145 |
| 150 | | | | | 1.0 | | 150 |

This material is supplied for reference use only. Operator must refer to in-cab Crane Rating Manual and Operator's Manual to determine allowable crane lifting capacities and assembly and operating procedures.