

# Technical Data

## Specifications & Capacities

# TCC 550

Telescopic Crawler Crane  
55 US ton  
51 metric ton



**CAUTION:** This material is supplied for reference use only. Operator must refer to in-cab Crane Rating Manual and Operator's Manual to determine allowable crane lifting capacities and assembly and operating procedures.



# Table Of Contents

<b>Upper Structure</b> .....	<b>1</b>
Frame .....	1
Engine .....	1
Hydraulic System .....	1
Load Hoist Drums .....	1
Swing System .....	1
Counterweight .....	1
Operator's Cab .....	1
Rated Capacity Limiter System .....	2
Machinery House .....	2
Catwalks .....	2
Optional Vandal Guards .....	2
<b>Lower Structure</b> .....	<b>2</b>
Carbody .....	2
Side Frames .....	2
Travel and Steering .....	2
Tool Boxes .....	2
<b>Boom</b> .....	<b>3</b>
Design .....	3
Boom .....	3
Boom Head .....	3
Boom Elevation .....	3
Auxiliary Lifting Sheave .....	3
<b>Optional Equipment</b> .....	<b>3</b>
Hook Blocks And Balls .....	3
Fly & Attachments .....	3
<b>Dimensions</b> .....	<b>4</b>
Base Crane .....	4
Auxiliary Lifting Sheave .....	6
Fly .....	6
Counterweights .....	7
Optional XL Counterweight .....	7
Hookballs .....	8
Hook Blocks .....	8
<b>Working Weights</b> .....	<b>9</b>
<b>Transport Drawing</b> .....	<b>9</b>
<b>Load Hoist Performance</b> .....	<b>9</b>
<b>Working Areas</b> .....	<b>10</b>
<b>Boom Extend Modes</b> .....	<b>10</b>
<b>Attachments</b> .....	<b>11</b>
<b>Main Boom Working Range Diagrams</b> .....	<b>12</b>
<b>Main Boom Load Charts</b> .....	<b>13</b>
<b>Main Boom Load Charts (Metric)</b> .....	<b>15</b>
<b>Main Boom + Fly Load Charts</b> .....	<b>17</b>
<b>Main Boom + Fly Load Charts (Metric)</b> .....	<b>19</b>

**This page intentionally left blank**

# Upper Structure

## Frame

All welded steel frame with precision machined surfaces for mating parts.

### Turntable Bearing

- Inner race is bolted to upper frame
- Outer race with external swing gear is bolted to lower frame

## Engine

### Engine

Full pressure lubrication, oil filter, air cleaner, hour meter, throttle, and electric control shutdown.

Specification	Cummins QSB
	Tier 4f (Stage IV)
Numbers of Cylinders	6
Cycle	4
Bore & Stroke: inch (mm)	4.21 x 4.88 (107 x 124)
Piston Displacement: in <sup>3</sup> (L)	409 (6.7)
Max. Brake Horsepower: hp (kW)	215 (160) @ 1,800 rpm
Peak Torque: ft lb (Nm)	700 (949) @ 1,500 rpm
Alternator: volt - amps	12 - 150
Crankcase Capacity: qt (L)	19 (18)
<ul style="list-style-type: none"> <li>• Engine driven variable speed viscus fan clutch and thermostatically controlled radiator</li> </ul>	

### Fuel Tank

One 80 gal (303L) capacity fuel tank.

## Hydraulic System

### Hydraulic Pumps

The pump arrangement is designed to provide hydraulically powered functions allowing positive, precise control with independent or simultaneous operation of all crane functions.

- Two variable displacement pumps provide independent control for hoist drums, boom hoist, boom extend, and right & left travel.
- Two gear type pumps are used for the swing, retract cylinders & operator's controls, and hydraulic oil cooling fan.

### Hydraulic Reservoir

133 gal (504L) capacity equipped with sight level gauge. Diffusers built in for deaeration.

### Filtration

One 10 micron, full flow return line filter. Accessible for easy filter replacement.

### Counterbalance Valves

All hoist motors are equipped with counterbalance valves to provide positive load lowering and prevent accidental load drop if the hydraulic pressure is suddenly lost.

## Load Hoist Drums

### Main and Optional Auxiliary Winches

- Axial piston, full and half displacement (2- speed) motor driven through planetary reduction unit for positive control under all load conditions.
- Grooved lagging
- Power up/down mode of operation
- Hoist drum cable follower - optional
- Drum rotation indicator
- Drum diameter: 10.63 in (27cm)
- Rope length:
  - Main: 550 ft (182.9m)
  - Auxiliary: 450 ft (137.2m) or 500 ft (182.9m)
- Maximum rope storage: 737 ft (224.6m)
- Terminator style socket and wedge

### Third Wrap Indicator - Optional -

Visually and audibly warns the operator when the wire rope is on the first/bottom layer and when the wire rope is down to the last three wraps.

## Swing System

**Motor/Planetary** - Bi- directional hydraulic swing motor mounted to a planetary reducer for 360° continuous smooth swing at 2.0 rpm

**Swing Park Brake** - 360°, electric over hydraulic, (spring applied/hydraulic released) multi- disc brake mounted on the speed reducer. Operated by a switch in the operator's cab.

**Swing Brake** - 360°, foot operated, hydraulic swing valve regulates flow to the swing motor acting as a service brake

**House Lock** - Two- position house lock (boom over front or rear) operated from the operator's cab

## Counterweight

Consists of a five piece design.

- One "A" counterweight, 12,000 lb (5.4mt)
- One "B" counterweight, 13,000 lb (5.8mt)
- Optional one "C" counterweight, 5,000 lb (2.6mt)
- Optional two "A" carbody counterweights, 3,000 lb (1.3mt) each with tool box built in

## Operator's Cab

Fully enclosed modular steel compartment is independently mounted and padded to protect against vibration and noise.

- All tinted/tempered safety glass
- Sliding entry door and front and rear window
- Swing up roof window with windshield wiper
- Door and window locks
- Hot water heater
- Air conditioner
- Sun visor
- Cloth seat
- Circulating fan
- Windshield wipers and washer
- Dry chemical fire extinguisher
- Engine instrumentation panel (tachometer, voltmeter, engine oil pressure, engine water temperature, fuel level, hydraulic oil temperature, hour meter, and service monitor system)
- Mechanical drum rotation indicators for main (rear) and auxiliary (front) hoist drums
- Six way adjustable seat
- Foot throttle
- Joystick controls
- Bubble type level
- Ergonomic gauge layout
- Controls shut off lever
- AM/FM Radio
- Travel levers & pedals
- Camera (winch, rear view, & right side)
- Fully adjustable single axis controls - optional

## Rated Capacity Limiter System

**Link- Belt Pulse** - The Link- Belt in-house designed, total crane operating system that utilizes the display as a readout and operator interface for the following systems:

- Crane configuration
- Boom length
- Boom head height
- Allowed load and % of allowed load
- Data logging
- Boom angle
- Radius of load
- Actual load

- Operator settable alarms (include):
  - Maximum and minimum boom angles
  - Maximum tip height
  - Maximum boom length
  - Swing left/right positions
  - Operator defined area (imaginary plane)

**Telematics** - Cellular- based data logging and monitoring system that provides:

- Location and operational settings
- Routine maintenance
- Crane and engine monitoring
- Diagnostic and fault codes

## Machinery House

- Hinged doors (four on right side) for machinery access
- Textured paint finish

## Catwalks

Standard on right and left sides. Catwalks fold up and pin for reduced travel width.

## Optional Vandal Guards

Under design

# Lower Structure

## Carbody

### Lower Frame

All welded box construction frame with precision machined surfaces for turntable bearing and rotating joint.

## Side Frames

### Side Frames

All welded, precision machined, steel frames can be hydraulically extended and retracted with a hydraulic cylinder mounted in the lower frame.

- 12 ft 6.9 in (3.8m) extended gauge
- 10 ft 10.6 in (3.3m) intermediate gauge
- 8 ft 9.8 in (2.7m) retracted gauge
- 19 ft 6.2 in (5.9m) overall length
- 31.5 in (0.80m) wide track shoes
- Sealed (oil filled) idler and drive planetaries
- Compact travel drives
- Hydraulic self adjusting tracks

### Track Rollers

- Eleven sealed (oil filled) track rollers per side frame
- Heat treated, mounted on anti- friction bearings

### Tracks

Heat treated, self- cleaning grouser shoes and heat treated track pins with dirt seals. 61 track shoes per side.

- Optional flat or "street" pad

### Take Up Idlers

Cast steel, heat treated, self- cleaning, mounted on sealed tapered roller bearings

## Travel and Steering

Each side frame contains a pilot controlled, bi- directional, axial piston motor and a planetary gear reduction unit to provide positive control under all load conditions.

- 2- speed travel
- Individual control provides smooth, precise maneuverability including full counter- rotation.
- Spring applied, hydraulically released multiple wet- disc type brake controlled automatically
- Maximum travel speed is 2 mph (3.2km/h).
- Designed to 40% gradeability

## Tool Boxes

Integrated into carbody counterweights.

# Boom

## Design

Four section, greaseless formed boom with Teflon wear pads constructed of high tensile steel consisting of one base section and three telescoping sections. The first telescoping section extends independently by means of one double-acting, single stage hydraulic cylinder with integrated holding valves. The second and third telescoping sections extend proportionally by means of one double-acting, single stage cylinder with integrated holding valves and cables.

## Boom

- 36 ft 8 in- 115 ft (11.2- 35.05m) four section full power boom
- Two mode boom extensions: In mode EM1, the T1, T2, and T3 sections extend and retract synchronously to a maximum of 115.0' boom length. In mode EM2, only the T1 section extends to reach a 62.8' boom length. The T2 and T3 sections do not extend and will stay retracted inside the T1 section.
- Mechanical boom angle indicator
- Maximum tip height for EM2 mode is 69 ft (21.1m) and EM1 is 120 ft (36.7m).

## Boom Head

- Four 16.5 in (41.9cm) root diameter sealed bearing nylon sheaves to handle up to eight parts of line
- Easily removable wire rope guards
- Rope dead end lugs on each side of the boom head
- Boom head is designed for quick-reeve of the hook block

## Boom Elevation

- One double acting hydraulic cylinder with integral holding valve
- Boom elevation: - 3° to 78°

## Auxiliary Lifting Sheave

- Single 16.5 in (41.9m) root diameter nylon sheave
- Easily removable wire rope guard
- Does not affect erection of the fly or use of the main head sheaves

---

# Optional Equipment

## Hook Blocks And Balls

- 41 ton (37mt) 3 sheave quick-reeve hook block with safety latch
- 60 ton (55mt) 5 sheave quick-reeve hook block with safety latch
- 8.0 ton (7.25mt) swivel hook ball with safety latch

## Fly & Attachments

- 28.5- 51 ft (8.7- 15.6m) two piece bi-fold lattice fly, stowable, offsettable to 2°, 20°, and 40°. Maximum tip height is 172 ft (52.4m).

# Dimensions

## Base Crane

General Dimensions	English	Metric
Basic Boom	36.8- 115 ft	11.2- 35.5m
Minimum Load Radius	9 ft	2.5m
Maximum Boom Angle	78°	78°
Track Shoe Width	32 in	0.81m

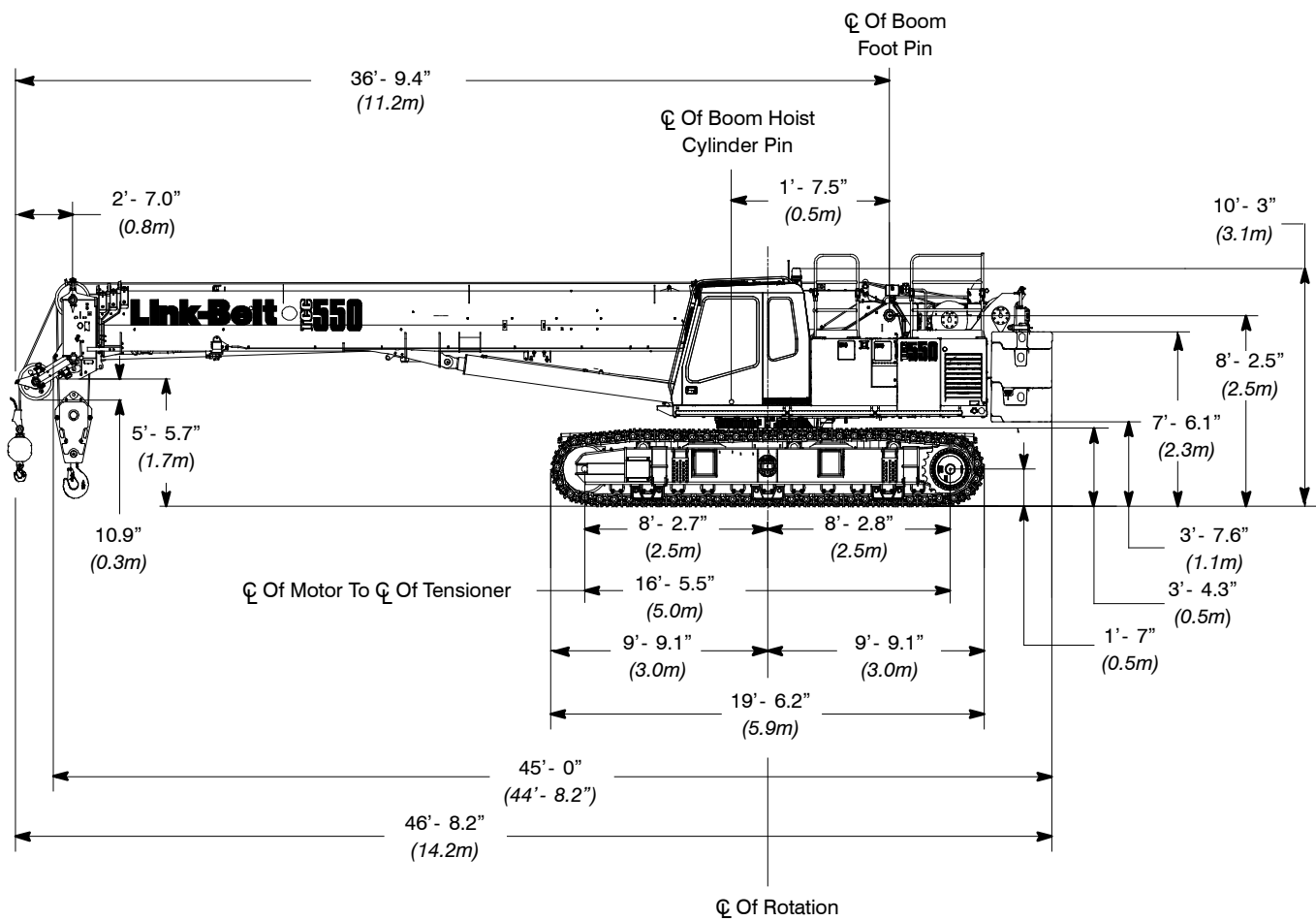



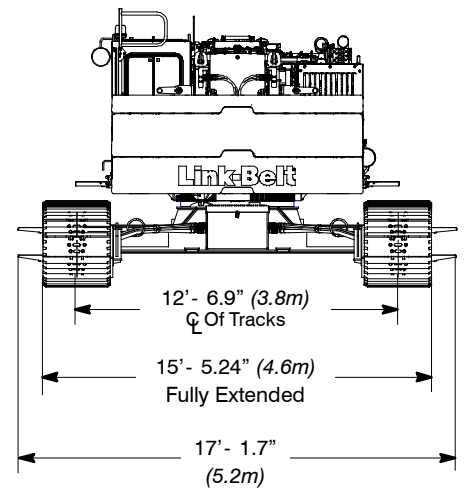
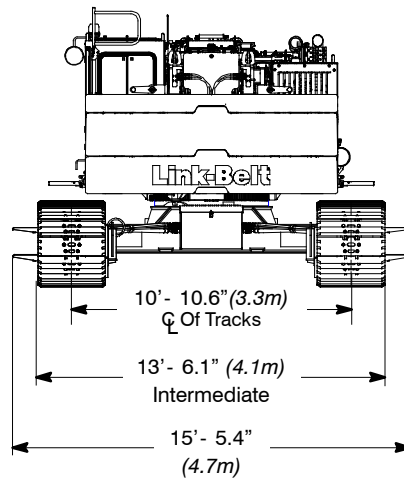
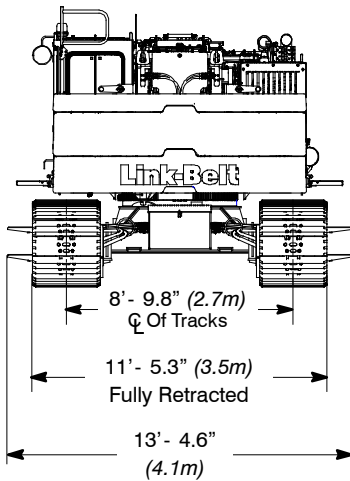
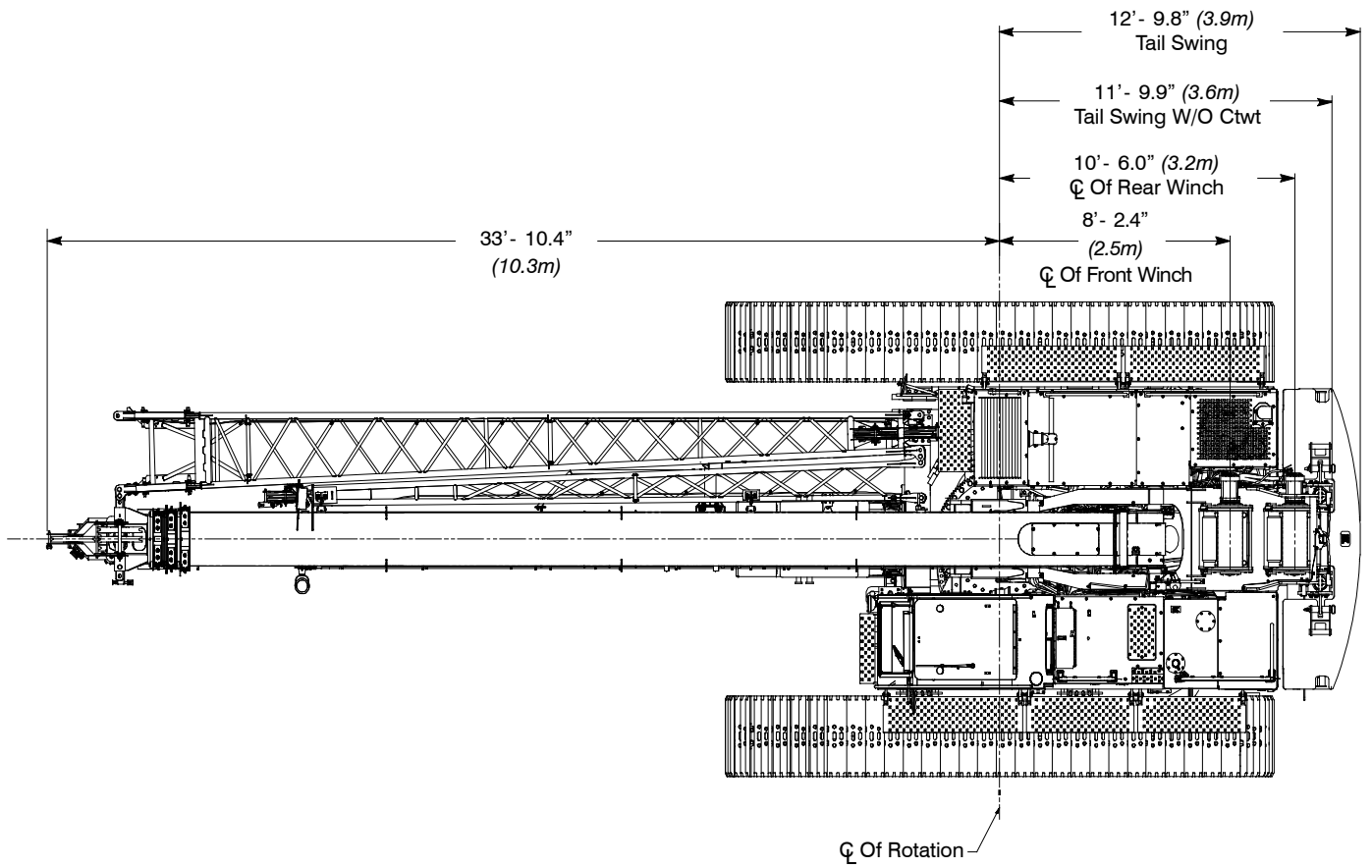

# Auxiliary Lifting Sheave

## Auxiliary Lifting Sheave ①

Length	35.31 in	(0.90m)
Width	16.31 in	(0.41m)
Height	19 in	(0.48m)
Weight	92.5 lb	(42kg)

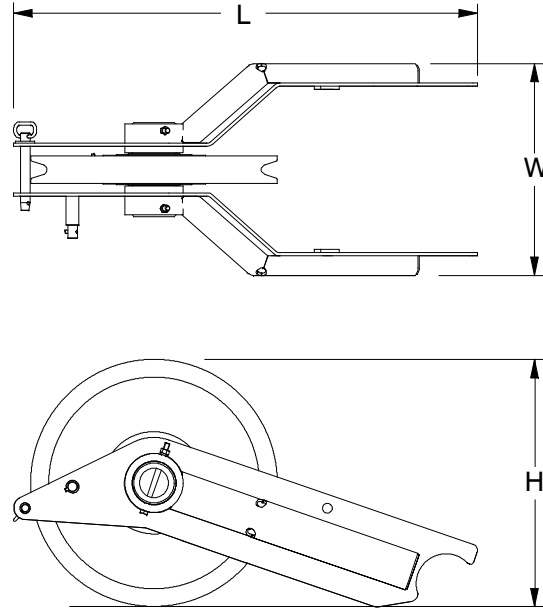

# Fly

## 28.5 ft (8.69m) Offset Fly One Piece Lattice Fly (Base Fly) ①

Length	28.5 ft	(8.69m)
Width	29 in	(0.74m)
Height	30 in	(0.76m)
Weight	1,188 lb	(539kg)

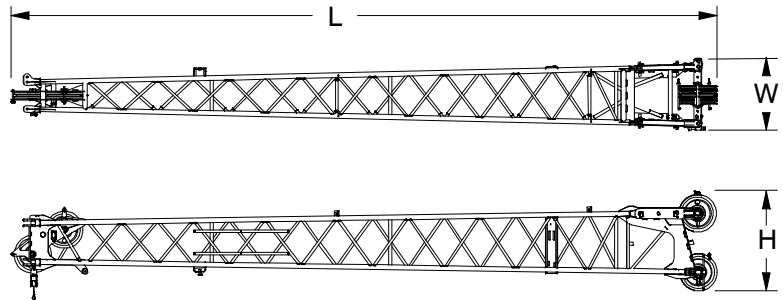

## 22.5 ft (6.86m) Lattice Fly Tip (Addition To Base Fly For 28.5- 51 ft (8.69- 15.55m) Bi- fold Fly) ①

Length	22.5 ft	(6.86m)
Width	13.78 in	(0.35m)
Height	20 in	(0.51m)
Weight	654 lb	(297kg)

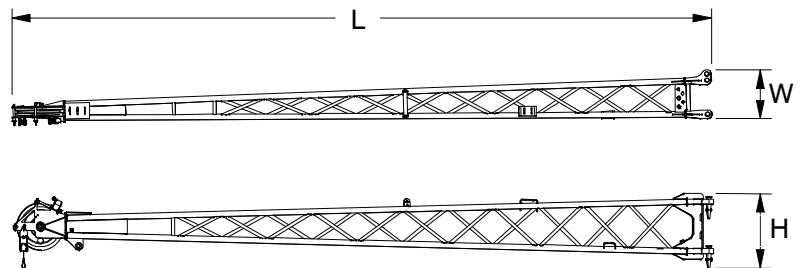

Number inside black circle “①” = # of components

\* - Optional equipment

# Counterweights

## "A" Counterweight ①

Length	32.90 in	(0.84m)
Width	9 ft 10 in	(3.00m)
Height	4 ft 2.18 in	(1.28m)
Weight	12,000 lb	(5.4mt)

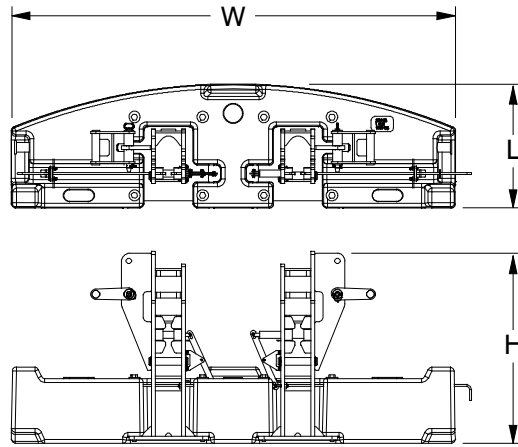

## "B" Counterweight ①

Length	32.90 in	(0.84m)
Width	9 ft 10 in	(3.00m)
Height	23 in	(0.58m)
Weight	13,000 lb	(5.8mt)

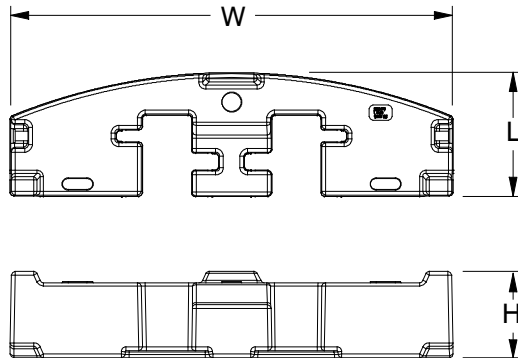

# Optional XL Counterweight

## Optional "C" Counterweight ①

Length	32.90 in	(0.84m)
Width	9 ft 10 in	(3.00m)
Height	8.50 in	(0.22m)
Weight	5,000 lb	(2.2mt)

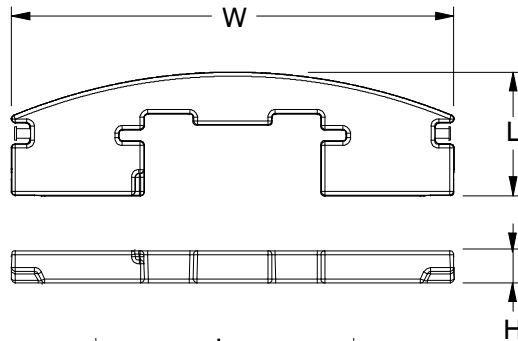

## Optional "A" Carbody Counterweights ②

Length	62.50 in	(1.59m)
Width	30 in	(0.76m)
Height	20.12 in	(0.51m)
Weight	3,000 lb	(1.3mt)

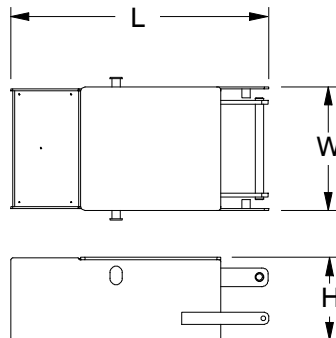

Number inside black circle "①" = # of components  
 \* - Optional equipment

# Hookballs

## 8.0 Ton (7.25mt) Swivel

### Hook Ball\* 1

Width	13.56 in	(0.34m)
Height	28.94 in	(0.74m)
Weight	320 lb	(145kg)

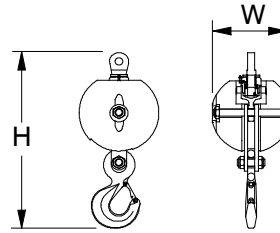

# Hook Blocks

## 41 Ton (37mt)

### 3- Sheave Hook Block\* 1

Width1	10.13 in	(0.27m)
Width2	19.69 in	(0.50m)
Height	56.5 in	(1.44m)
Weight	843 lb	(378kg)

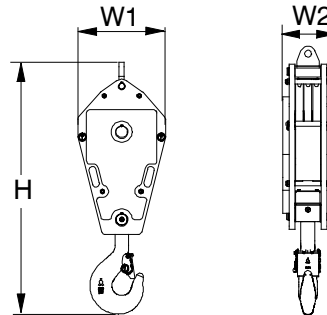

## 60 Ton (55mt)

### 5- Sheave Hook Block\* 1

Width1	14.65 in	(0.37m)
Width2	19.69 in	(0.50m)
Height	55.03 in	(1.40m)
Weight	1,096 lb	(497kg)

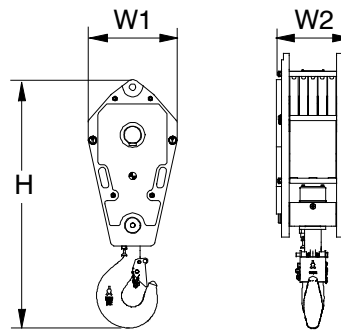

Number inside black circle "1" = # of components

\* - Optional equipment

# Working Weights

Option	Description	Gross Weight lb (kg)	Ground Bearing Pressure (on soft ground) psi (kg/cm <sup>2</sup> )
1	Base crane, "AB" counterweight, 550 ft (182.9m) type "KC" main wire rope, 450 ft (137.2m) type "KC" auxiliary wire rope, 2- piece fly, 41 ton (36.29mt) 3 sheave hook block, 8.0 ton (7.3mt) hook ball, and a 250 lb (113kg) operator.	99,850 (45 291kg)	8.57 (0.60)
2	Base crane, "ABC+A" counterweight, lower toolbox, 550 ft (182.9m) type "KC" main wire rope, 450 ft (137.2m) type "KC" auxiliary wire rope, 2- piece fly, 40 ton (36.29mt) 3 sheave hook block, 8 ton (7.3mt) hook ball, and a 250 lb (113kg) operator.	109,850 (49 827kg)	8.57 (0.60)

Notes: Ground bearing pressure is based on the total weight distributed evenly over the track contact area.

# Transport Drawing

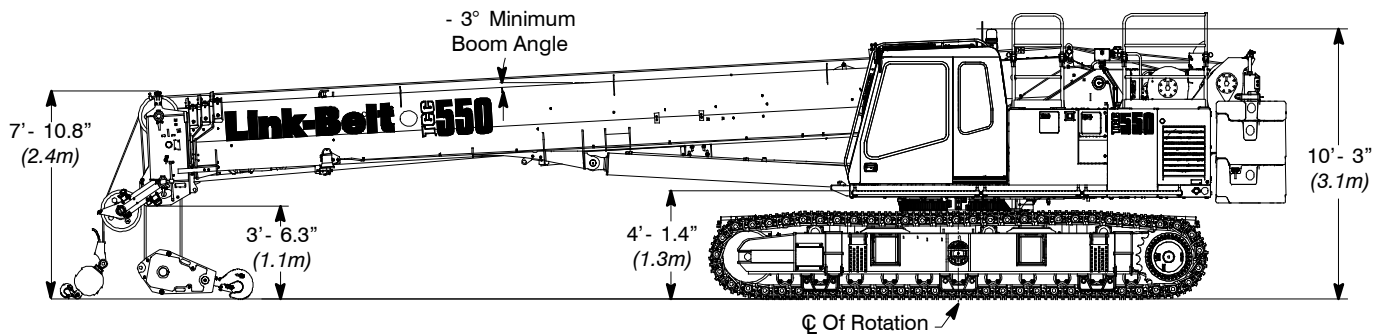

## Transport Weight - 99,850 lb (45 291kg)

Base crane, "AB" Counterweight, 550 ft (182.9m) type "KC" main wire rope, 450 ft (137.2m) type "KC" auxiliary wire rope, 2- piece fly, 41 ton (36.29mt) 3 sheave hook block, and 8 ton ball

# Load Hoist Performance

Main (Rear) and Auxiliary (Front) Winches - 5/8 in (16mm) Rope										
Layer	Maximum Line Pull		Normal Line Speed		High Line Speed		Layer		Total	
	lb	kg	ft/min	m/min	ft/min	m/min	ft	m	ft	m
1	17,084	7 749.1	181	55.2	360	109.6	97	29.6	97	29.6
2	15,454	7 009.8	200	61.1	398	121.2	107	32.6	205	62.4
3	14,107	6 398.8	219	66.9	436	132.8	118	35.9	322	98.3
4	12,977	5 886.2	239	72.7	474	144.3	128	39.0	451	137.3
5	12,014	5 449.4	258	78.6	511	155.9	138	42.1	589	179.5
6	11,184	5 072.9	277	84.4	549	167.5	149	45.3	737	224.7

Wire Rope Application		Diameter		Type	Maximum Permissible Load	
		in	mm		lb	kg
Main (Rear) Winch	Standard	5/8	16	37x7 galvanized rotation resistant - right lang lay (Type KC) 35x7 rotation resistant - right lang lay (Type CC)	10,835	4 914
	Optional	5/8	16		12,240	5 552

# Working Areas

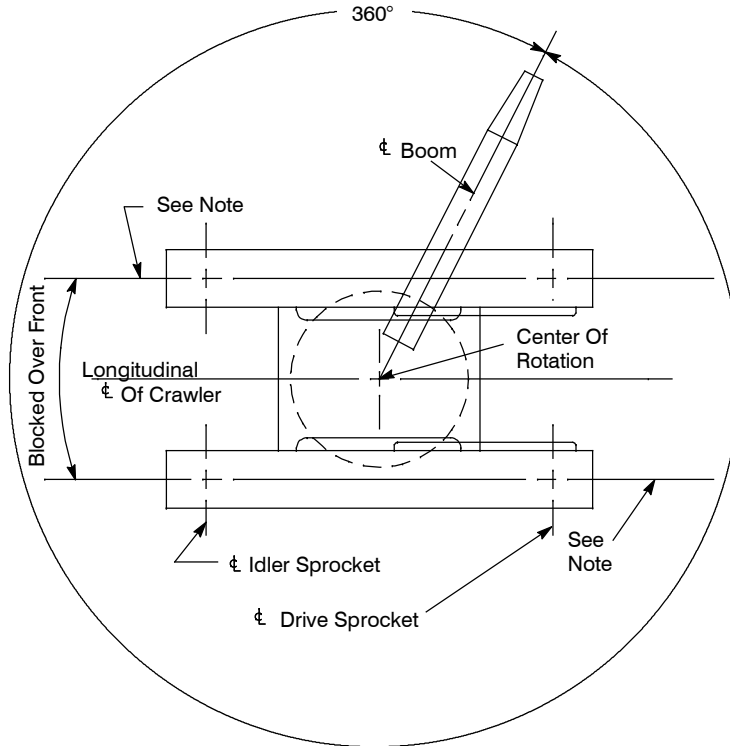

**Note:** These Lines Determine The Limiting Position Of Any Load For Operation Within Working Areas Indicated.

# Boom Extend Modes

Boom Length		Boom Mode		
ft	m	T3	T2	T1
36.8	11.20			
45	13.72	11%	11%	11%
55	16.76	23%	23%	23%
65	19.81	36%	36%	36%
75	22.86	49%	49%	49%
85	25.91	62%	62%	62%
95	28.96	74%	74%	74%
105	32.00	87%	87%	87%
115	35.05	100%	100%	100%

**EM 1**

Boom Length		Boom Mode		
ft	m	T3	T2	T1
36.8	11.20			
45	13.72			32%
55	16.76			70%
62.83	19.15			100%

**EM 2**

# Attachments

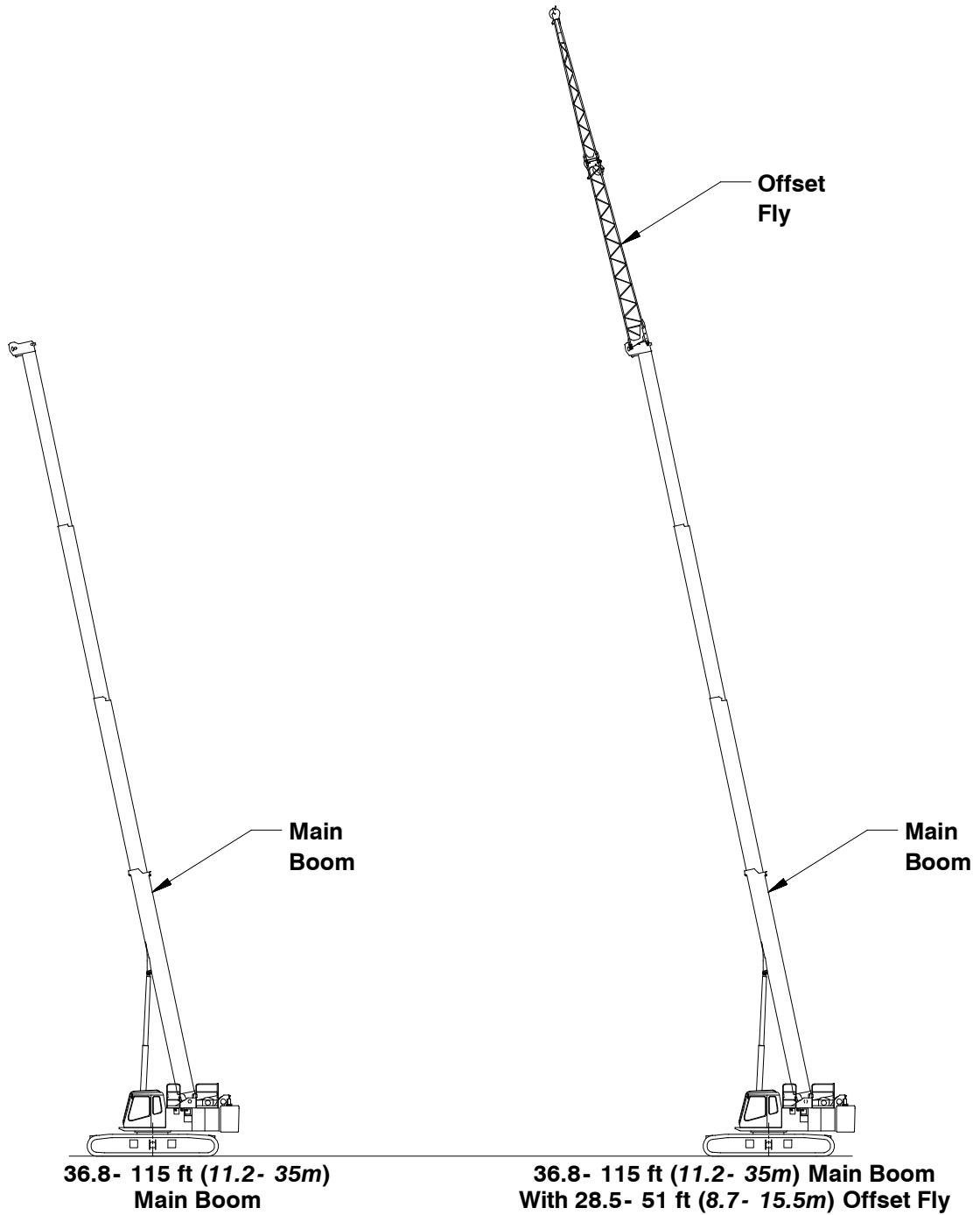

# Main Boom Working Range Diagrams

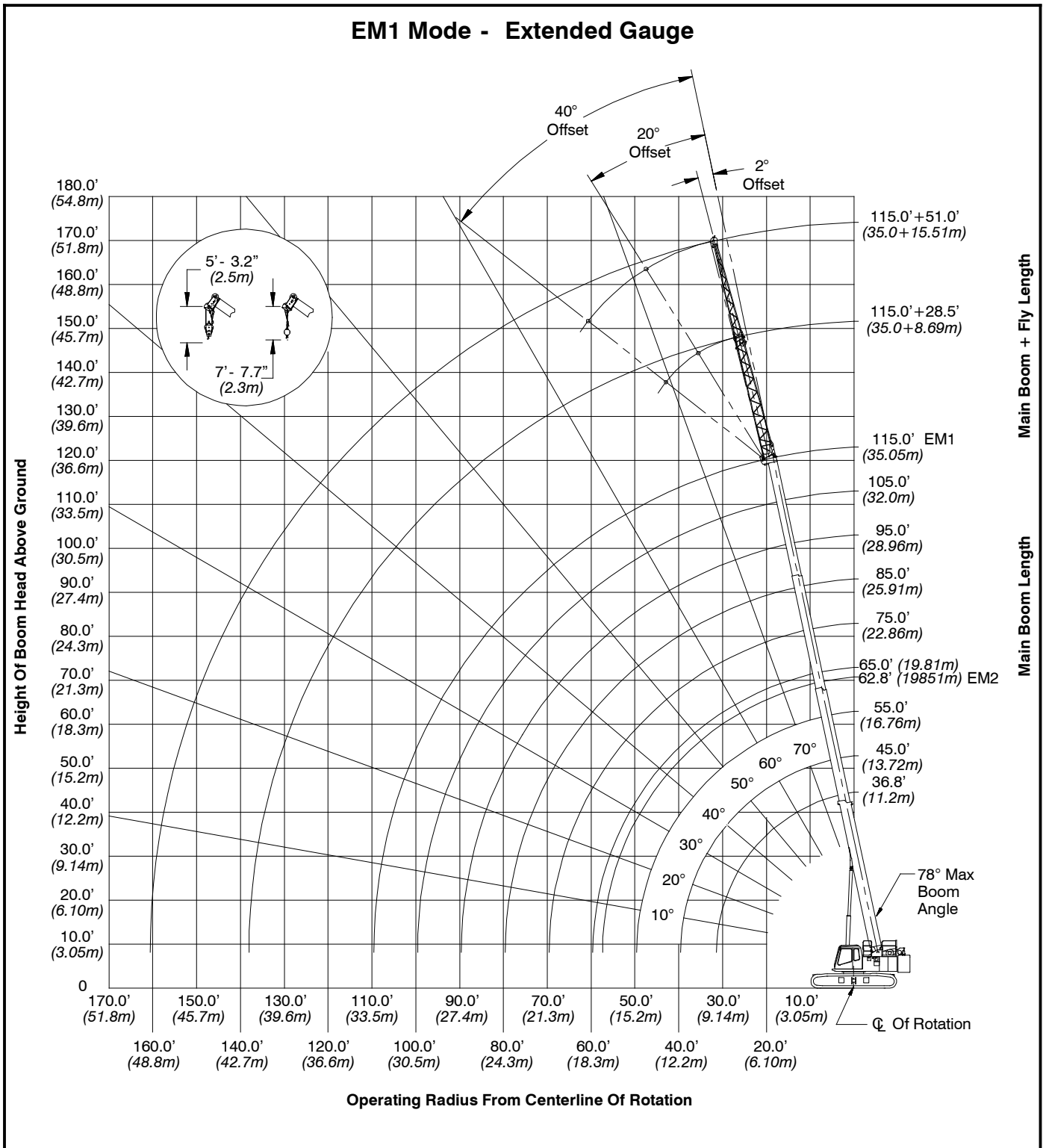



# Main Boom Load Charts

Main Boom Lift Capacity Chart - 360° Rotation - Side Frames Extended Position AB+0 [25,000 lb] Counterweight [All capacities are listed in kips]										
Load Radius (ft)	Boom Length (ft)									Load Radius (ft)
	36.8	45	55	62.8- 65	75	85	95	105	115	
9	110.0									9
10	102.2	83.3	81.9							10
12	91.5	83.3	81.4	68.2						12
15	74.0	73.4	70.5	60.7	39.2					15
20	44.5	44.2	43.8	43.6	39.2	37.1				20
25	30.7	31.4	31.9	32.1	32.2	32.1	28.6	26.1		25
30	22.6	23.3	23.8	24.1	24.2	24.3	24.4	22.9	20.8	30
35		18.1	18.6	18.9	19.1	19.2	19.3	19.3	18.8	35
40			14.9	15.2	15.4	15.5	15.6	15.7	15.7	40
45			12.1	12.4	12.6	12.8	12.9	12.9	13.0	45
50				10.3	10.5	10.7	10.8	10.8	10.9	50
55				8.6	8.8	9.0	9.1	9.2	9.3	55
60					7.5	7.6	7.8	7.8	7.9	60
65					6.3	6.5	6.6	6.7	6.8	65
70						5.5	5.6	5.7	5.8	70
75						4.7	4.8	4.9	5.0	75
80							4.1	4.2	4.3	80
85							3.5	3.6	3.6	85
90								3.0	3.1	90
95								2.5	2.6	95
100									2.2	100
105									1.8	105

This material is supplied for reference use only. Operator must refer to in- cab Crane Rating Manual and Operator's Manual to determine allowable crane lifting capacities and assembly and operating procedures.

Main Boom Lift Capacity Chart - 360° Rotation - Side Frames Extended Position ABC+A [36,000 lb] Counterweight [All capacities are listed in kips]										
Load Radius (ft)	Boom Length (ft)									Load Radius (ft)
	36.8	45	55	62.8- 65	75	85	95	105	115	
9	110.0									9
10	102.2	83.3	81.9							10
12	91.5	83.3	81.4	68.2						12
15	79.0	75.4	70.5	60.7	39.2					15
20	51.4	51.2	50.8	50.5	39.2	37.1				20
25	35.7	36.4	36.9	37.1	37.3	32.1	28.6	26.1		25
30	26.6	27.3	27.8	28.1	28.3	28.2	25.2	22.9	20.8	30
35		21.4	21.9	22.2	22.4	22.4	22.3	20.3	18.8	35
40			17.7	18.0	18.2	18.4	18.4	18.2	16.9	40
45			14.6	14.9	15.1	15.3	15.3	15.4	15.2	45
50				12.5	12.7	12.8	12.9	13.0	13.0	50
55				10.6	10.8	10.9	11.0	11.1	11.2	55
60					9.2	9.4	9.5	9.6	9.7	60
65					7.9	8.1	8.2	8.3	8.4	65
70						7.0	7.1	7.2	7.3	70
75						6.1	6.2	6.3	6.4	75
80							5.4	5.5	5.6	80
85							4.7	4.8	4.8	85
90								4.2	4.2	90
95								3.6	3.7	95
100									3.2	100
105									2.7	105

This material is supplied for reference use only. Operator must refer to in- cab Crane Rating Manual and Operator's Manual to determine allowable crane lifting capacities and assembly and operating procedures.