

Technical sheet :

1650 RT



 **MANITOU**
HANDLING YOUR WORLD

Capacities		Imperial
Operating Weight		8020 lb
Operating Capacity at 35% Tipping Load		1649 lb
Operating Capacity At 50% Tipping Load		2357 lb
Tipping capacity		4716 lb
Weight and dimensions		
Overall Operating Height - Fully Raised	h27	158 in
Height to Hinge Pin – Fully Raised	h28	120 in
Reach - Fully Raised	dp1	25 in
Dump angle at full height	a5	39 °
Dump Height - Fully Raised	h29	92 in
Maximum Rollback Angle - Fully Raised	a4	98 °
Overall Height to Top of ROPS	h17	78 in
Overall length with bucket	l16	126 in
Overall Length without Bucket	l1	94 in
Specified Height	h31	64 in
Reach at Specified Height	r4	22 in
Dump angle at specified height	a17	73 °
Maximum Rollback Angle at Ground	a13	28 °
Carry Position	d5	8 in
Maximum Rollback Angle at Carry Position	a14	28 °
Digging Position	h32	2 in
Angle of Departure with STD Counterweight		28 °
Ground clearance	m4	606 ft 11 in
Track gauge	b10	53 in
Track Shoe Width	b20	13 in
Crawler base	y2	50 in
Overall width less bucket	b1	66 in
Bucket Width	e1	66 in
Clearance Radius - Front with Bucket	b18	78 in
Clearance Circle - Rear	wa1	57 in
Maximum rollback at specified height		62 °
Angle of Approach	a3	90 °
Grouser Height		0.98 in
Track Type / Track Rollers / Roller Type		Rubber / 3 / Steel
Performances		
Ground Speed - Single Speed		7 mi/h
Ground Speed - Two Speed		10 mi/h
Drawbar Pull/Tractive Effort		9579 lb
Bucket Breakout - Tilt Cylinder		4231 lb
Bucket Breakout - Lift Cylinder		5060 lb
Engine		
Engine brand		Yanmar
Engine model		4TNV98C-NMS2
Motor Type		Radial Piston
Gross Power (kW) / Power		51.70 kW @ 2500 rpm
Net Power (kW) / Power		51 kW / 2500 rpm
Max. torque		241 Nm
Battery		12 V
Cold Cranking Amps at Temperature (CCA)		950 A
Alternator - Voltage / Ampere		12 V / 100 A
Hydraulics		
Standard flow - Auxiliary hydraulics		71 l/min
Tank capacities		
Oil Pan Capacity		2 US gal
Hydraulic tank capacity		10 US gal
Fuel tank		17 US gal
Coolant system capacity		3 US gal
Displacement / Number of cylinders		0.87 US gal / 4
Miscellaneous		
Ground Pressure		7 PSI

1650 RT - Dimensional drawing

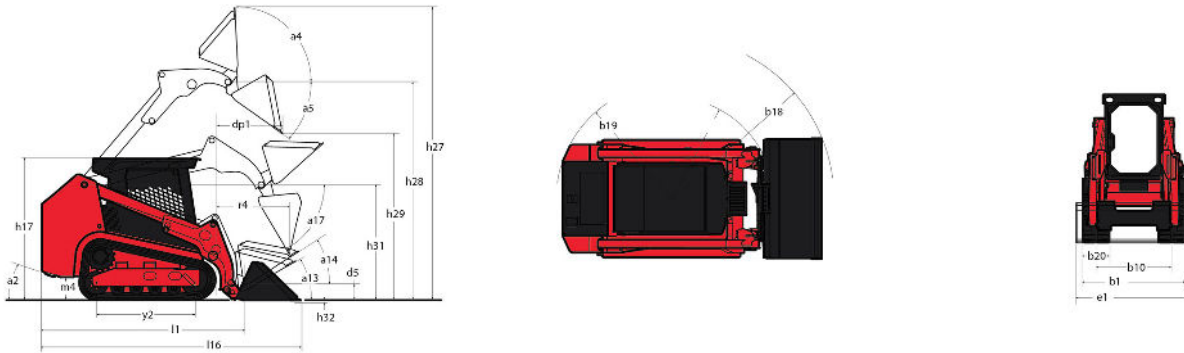

Equipment

Lifting function	
All-Tach® Attachment Mounting System	Standard
Auxiliary Hydraulics	Standard
Electronic Attachment Control - 14-Pin Connector	Optional
High-Flow Auxiliary Hydraulics	Optional
IdealTrax™ Automatic Track Tensioning System	Standard
Power-A-Tach® Attachment Mounting System	Optional
Motorization/Power	
Combination Radiator & Hydraulic Oil Cooler	Standard
Dual-Element Air Cleaner with Indicator	Standard
Engine Auto-Shutdown System	Standard
Glowplugs Starts Assist	Standard
Servo-Controlled Hydrostatic Drive	Standard
Two-Speed Hydrostatic Drive System	Standard
Operator station	
Air suspension seat	Optional
Foot Throttle	Standard
Full-Suspension Seat	Standard
Multi-Function Display Screen	Standard
Pressurized Cab Enclosure with A/C	Optional
Rearview Camera	Optional
ROPS/FOPS Level II Overhead Guard	Standard
Sliding Side Windows	Standard
Swing-out Cab Door	Standard
Other options	
Selectable Self-Leveling Hydraulic Lift Action 4	Optional
Pneumatics	
Rubber Track Undercarriage System	Standard
Single Flange Front/Dual Flange Rear Idlers	Standard
Secondary functions	
Counterweight	Standard
Dedicated Undercarriage	Standard
Security	
Anti-Vandalism Lock Provisions	Standard
Back-Up Alarm	Optional
Easy Manager	Standard
Engine Alert System with Error Display	Standard
Mechanical Lift Cylinder Lock	Standard



Siège Social
430 rue de l'Aubinière - 44150 Ancenis Cedex - France
Tel: +33(0)2 40 09 10 11 - Fax: +33 (0)2 40 09 10 97
www.manitou.com



This brochure describes versions and configuration options for Manitou products which may be fitted with different equipment. The equipment described in this brochure may be standard, optional or not available depending on version. Manitou reserves the right to change the specifications shown and described at any time and without prior warning. The manufacturer is not liable for the specifications given. For more information, contact your Manitou dealer. Non-contractual document. Product descriptions may differ from actual products. List of specifications is not comprehensive. The logos and visual identity of the company are the property of Manitou and may not be used without authorisation. All rights reserved. The photos and diagrams contained in this brochure are provided for information only.

MANITOU BF SA - Limited company with board of directors - Share capital: 39,668,399 euros - 857 802 508 RCS Nantes