

Technical sheet :

1900 R



Capacities		Imperial
Rated Operating Capacity		1900 lb
Rated Operating Capacity with Optional Counterweight		2110 lb
Unladen weight		6881 lb
Weight and dimensions		
Overall Operating Height - Fully Raised	h27	158 in
Height to Hinge Pin - Fully Raised	h28	121 in
Overall Height to Top of ROPS	h17	80 in
Dump angle at full height	a5	42 °
Dump height	h29	91 in
Overall length with bucket	l16	127 in
Dump reach - Full height	r6	23 in
Rollback at ground		26 °
Seat to ground height	h30	39 in
Wheelbase	y	42 in
Overall width less bucket	b1	64 in
Bucket Width	e1	66 in
Ground clearance	m4	6 in
Overall length - Less Bucket	l2	94 in
Departure angle	a2	25 °
Clearance Circle - Front without Bucket	b19	44 in
Clearance Circle - Rear	wa1	59 in
Performances		
Travel Speed with Two-Speed Option - Maximum		12 mi/h
Travel speed (unladen)		8 mi/h
Wheels		
Standard tyres		10.00x16.5 HD
Engine		
Engine brand		Yanmar
Engine model		4TNV98C-NMS
Gross Power (kW)		51.70 kW
Net Power (kW)		51 kW
Max. torque / Engine rotation		241 Nm / 2500 rpm
Battery		12 V
Alternator		95 kW
Starter (kW)		3 kW
Hydraulics		
Standard flow - Auxiliary hydraulics		70.10 l/min
Auxiliary Hydraulic Pressure		3002 PSI
High-Flow Auxiliary Hydraulics - Option		119 l/min
High-Flow Auxiliary Hydraulics Pressure - Option		2901 PSI
Tank capacities		
Fuel tank		17 US gal
Reservoir Capacity Hydraulics		8 US gal
Displacement		0.87 US gal
Noise and vibration		
Environmental noise (LwA)		101 dB
Noise at driving position (LpA)		85 dB
Whole-Body Vibration (ISO 2631-1)		0.80 m/s ²
Vibration to whole hand/arm		< 1.30 m/s ²

1900 R - Dimensional drawing

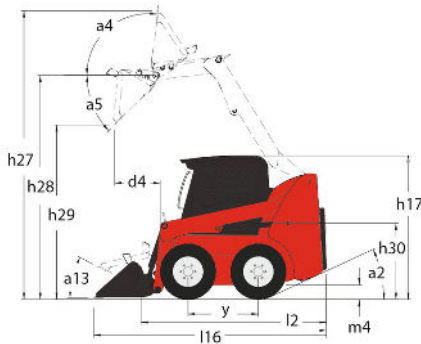

Equipment

—	
Integral Access Plate (removable)	Standard
Lifting function	
All-Tach® Attachment Mounting System	Standard
Auxiliary Hydraulics	Standard
High-Flow Auxiliary Hydraulics	Optional
Power-A-Tach® Attachment Mounting System	Optional
Lighting	
Work Lights - Front and Rear	Standard
Motorization/Power	
Engine Auto-Shutdown System	Standard
Engine Block Heater	Optional
Two-Speed Drive	Optional
Operator station	
Adjustable Arm Rests / Control Towers 1	Standard
Air conditioning with manual adjustment	Optional
Air suspension seat	Optional
Cab Enclosure	Optional
Dual-Hand Controls	Optional
Foot and Hand Throttles 2	Standard
Gehl T-Bar Controls	Optional
Hand/Foot Controls	Optional
Heating	Optional
High-Back Adjustable Seat	Standard
Hom	Standard
Joystick controls	Optional
ROPS/FOPS Level II Overhead Guard	Standard
Sound Reduction Material	Standard
Suspension Seat - Mechanical	Optional
Other options	
Hydrostatic Drive - Servo	Standard
Selectable Self-Leveling Hydraulic Lift Action 4	Optional
Secondary functions	
Counterweight	Optional
Full Instrumentation	Standard
Hydraglide™ Ride Control 3	Optional
Security	
Anti-Vandalism Protection	Standard
Back-Up Alarm	Optional
Brake Control (Auto / Manual)	Standard
Hydraloc™ Safety System	Standard
Lift Arm Support Device	Standard
Operator Restraint Bar	Standard



Siège Social
430 rue de l'Aubinière - 44150 Ancenis Cedex - France
Tel: +33(0)2 40 09 10 11 - Fax: +33 (0)2 40 09 10 97
www.manitou.com



This brochure describes versions and configuration options for Manitou products which may be fitted with different equipment. The equipment described in this brochure may be standard, optional or not available depending on version. Manitou reserves the right to change the specifications shown and described at any time and without prior warning. The manufacturer is not liable for the specifications given. For more information, contact your Manitou dealer. Non-contractual document. Product descriptions may differ from actual products. List of specifications is not comprehensive. The logos and visual identity of the company are the property of Manitou and may not be used without authorisation. All rights reserved. The photos and diagrams contained in this brochure are provided for information only.

MANITOU BF SA - Limited company with board of directors - Share capital: 39,668,399 euros - 857 802 508 RCS Nantes