

Technical sheet :

MHT 10230



 **MANITOU**
HANDLING YOUR WORLD

Capacities		Imperial
Max. capacity		50706 lb
Load centre of gravity	c	35 in
Max. lifting height		31 ft 8 in
Max. outreach		19 ft
Weight and dimensions		
Overall length	l1	22 ft 11 in
Unladen weight (with forks)		64595 lb
Ground clearance	m4	1 ft 7 in
Wheelbase	y	12 ft 10 in
Length to face of forks	l2	22 ft 11 in
Overall width	b1	9 ft 4 in
Overall height	h17	10 ft
Overall cab width	b4	3 ft 1 in
Tilt-down angle	a5	105 °
Tilt-up angle	a4	12 °
External turning radius (over tyres)	Wa1	17 ft 9 in
Outer turning radius (with forks)	b15	21 ft 10 in
Forks length / width / section	l / e / s	8 in x 4 in / 71 in
Frame levelling corrector	a9	10 °
Wheels		
Standard tyres		Aeolus - 18.00 R25 AIN 47
Number of front wheels / rear wheels		2 / 2
Steering wheels (front / rear)		2 / 2
Drive wheels (front / rear)		2 / 2
Steering mode		2 wheel steer, 4 wheel steer, Crab mode
Engine		
Engine brand		Mercedes
Engine norm		Stage IV / Tier 4 Final
Engine model		OM 934 LA. E4-3
Number of cylinders / Capacity of cylinders		4 - 311 in³
I.C. Engine power rating / Power (kW)		176 Hp / 129 kW
Max. torque / Engine rotation		553 ft/lbs@1600 rpm
Engine cooling system		Water
Number of batteries		2
Battery / Battery capacity		12 V / 120 Ah
Drawbar pull		18500 daN
Transmission		
Transmission type		Hydrostatic
Number of gears (forward / reverse)		2 / 2
Max. travel speed		16 mi/h
Parking brake		Automatic Negative Hand-brake
Service brake		Hydraulic
Gradeability (laden)		34 %
Hydraulics		
Hydraulic pump type		Variable pump
Hydraulic flow - Pressure		54 US gpm - 5076 PSI
Tank capacities		
Engine oil		6 US gal
Hydraulic oil		77 US gal
Fuel tank		83 US gal
Diesel Exhaust fluid (AdBlue® type)		17 US gal
Noise and vibration		
Noise at driving position (LpA)		80 dB
Noise to environment (LwA)		107 dB
Vibration on hands/arms		< 2.50 m/s²
Miscellaneous		
Safety cab homologation		Cabin ROPS - FOPS Level 2
Controls		JSM
Attachment recognition system (E-Reco)		Standard

MHT 10230 - Dimensional drawing

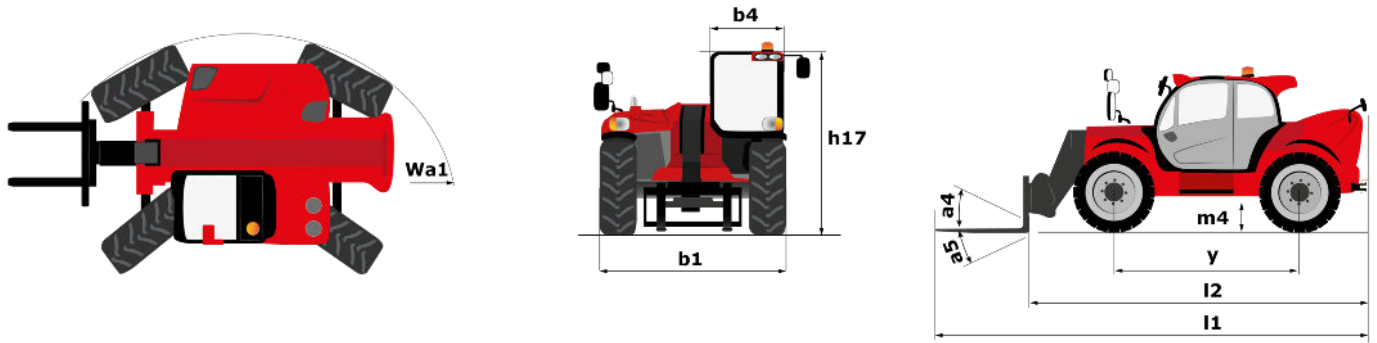

MHT 10230 - Load chart

Machine on tyres with forks LC 900 mm Imperial

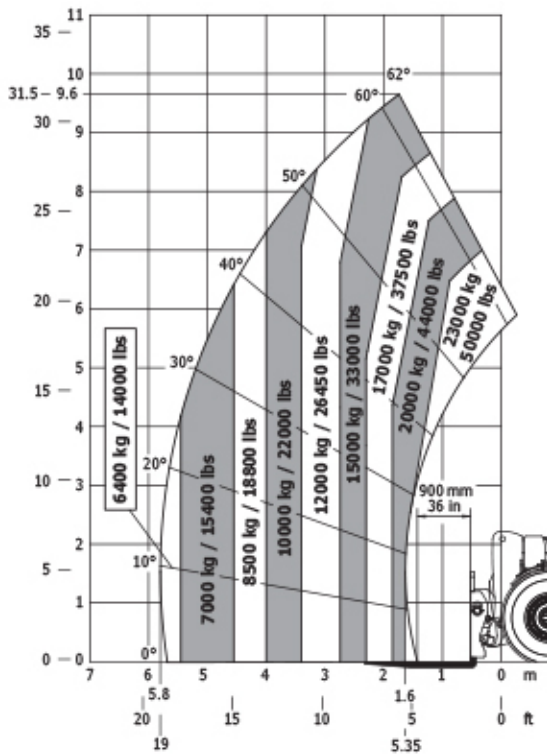

Machine on tyres with forks LC 1200 mm Imperial

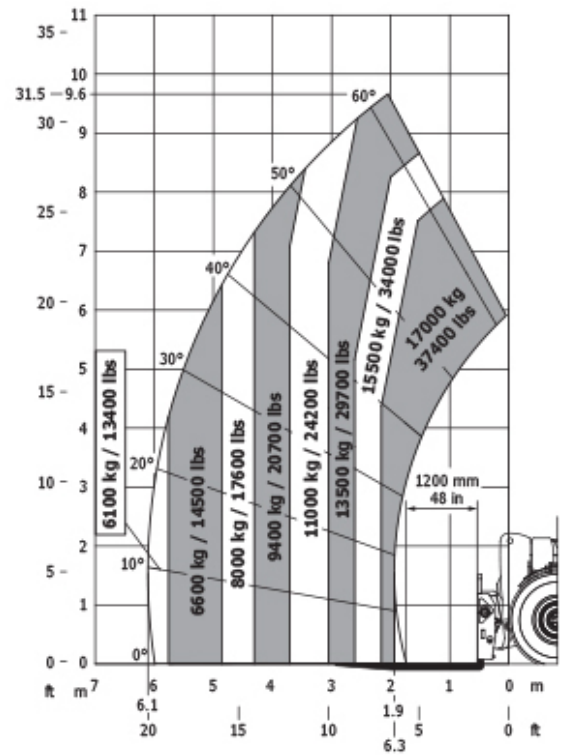

Machine on tyres with winch 25000 kg (Imperial)

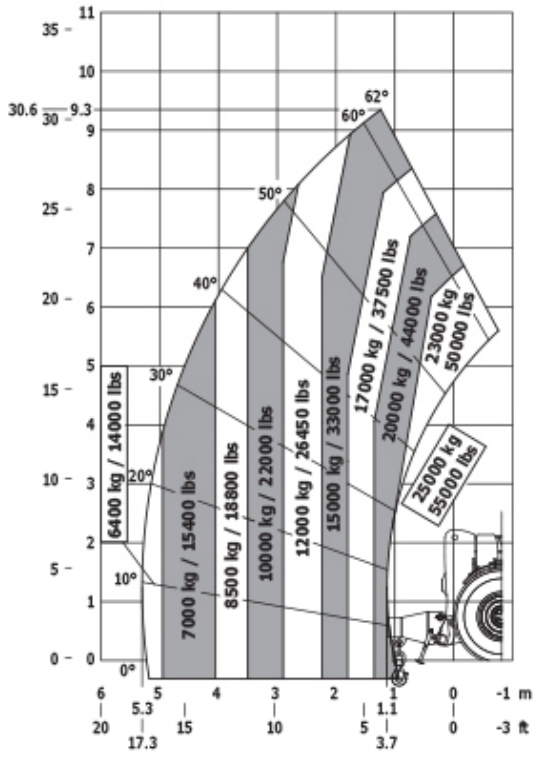

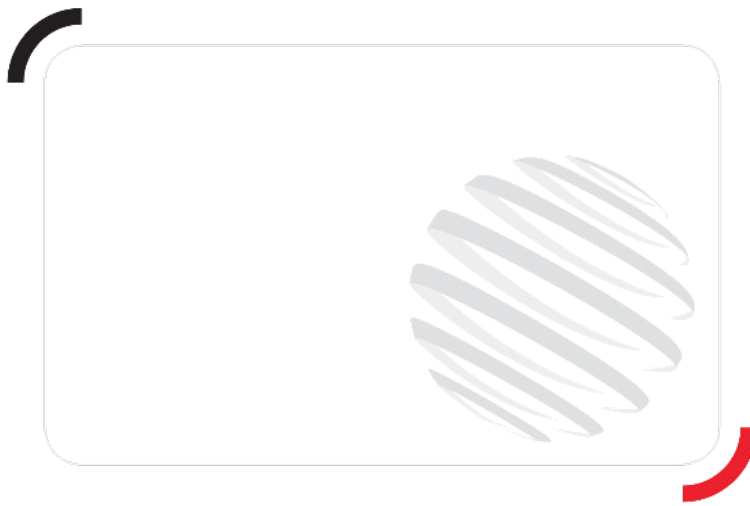

Head Office

B.P. 249 - 430 rue de l'Aubinière
44150 Ancenis Cedex - France

Tel: +33 (0)2 40 09 10 11 - Fax: +33 (0)2 40 09 10 97

www.manitou.com



This publication provides a description of the configuration versions and options for Manitou products, which may differ for equipment. The equipment presented in this brochure may be part of a series, as an option, or it may not be available, depending on the versions. Manitou reserves the right, at any time and without notice, to amend the specifications described and represented. The specifications provided do not bind the manufacturer. For more details, please contact your Manitou agent. This is not a contractually binding document. The presentation of the products is not contractually binding. List of specifications non-exhaustive. The logos as well as the visual identity of the company are owned by Manitou and cannot be used without authorisation. All rights reserved. The photos and diagrams contained in this brochure are only provided for consultation and information purposes.

MANITOU BF SA - Limited company with board of directors - Share capital: 39,668,399 euros - 857 802 508 RCS Nantes