

# S9056RT-HC/S9070RT-HC

ULTRA-HIGH CAPACITY ROUGH TERRAIN SCISSOR LIFTS



- Ultra-high capacity, large deck rough terrain scissor lifts
- Excellent rough terrain performance
- Heavy duty design
- Dual powered extension decks
- Ideal for construction applications

 **snorkel**™  
[www.snorkellifts.com](http://www.snorkellifts.com)

# ULTRA-HIGH CAPACITY ROUGH TERRAIN SCISSOR LIFTS

# S9056RT-HC/ S9070RT-HC

| DIMENSIONS                      | S9056RT-HC*       | S9070RT-HC* |
|---------------------------------|-------------------|-------------|
| Max. working height             | 62 ft             | 76 ft       |
| Max. platform height (A)        | 56 ft             | 70 ft       |
| Platform size (stowed)          | 16 ft x 7 ft 6 in |             |
| Platform size (extended)        | 27 ft x 7 ft 6 in |             |
| Extension deck length           | 4 ft 6 in         | 4 ft 6 in   |
| Overall width (B)               | 7 ft 6 in         | 7 ft 6 in   |
| Overall length (C)              | 16 ft             | 16 ft       |
| Stowed height (D)               | 10 ft 2 in        | 11 ft 3 in  |
| Min. height (guardrails folded) | 7 ft              | 8 ft 5 in   |
| Ground clearance                | 14 in             | 14 in       |

| PERFORMANCE                              | S9056RT-HC*           | S9070RT-HC* |
|--|-----------------------|-------------|
| Platform capacity (SWL)                  | 2,500 lbs             | 2,000 lbs   |
| Max. drive height                        | 43 ft                 | 43 ft       |
| Max. wind speed                          | 28 mph                | 28 mph      |
| Max. drive speed (stowed)                | 4.2 mph               | 4.2 mph     |
| Max. drive speed (elevated)              | 0.6 mph               | 0.6 mph     |
| Raise/lower time                         | 55/35 sec             | 70/40 sec   |
| Gradeability                             | 50%                   | 50%         |
| Max. stabilizer levelling, front to rear | 6°                    | 6°          |
| Max. stabilizer levelling, side to side  | 12°                   | 12°         |
| Inside turning radius                    | 8 ft                  | 8 ft        |
| Outside turning radius                   | 18 ft 6 in            | 18 ft 6 in  |
| Tires                                    | 13 x 36 foam filled   |             |
| Controls                                 | proportional joystick |             |
| Drive system                             | 4-wheel drive         |             |

| POWER        | S9056RT-HC*   | S9070RT-HC* |
|--------------|---------------|-------------|
| Power source | Kubota diesel |             |

| WEIGHT | S9056RT-HC* | S9070RT-HC* |
|--------|-------------|-------------|
| Weight | 20,000 lbs  | 25,500 lbs  |

## TURNING RADIUS

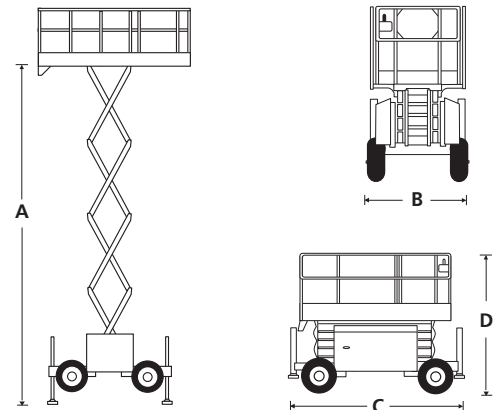
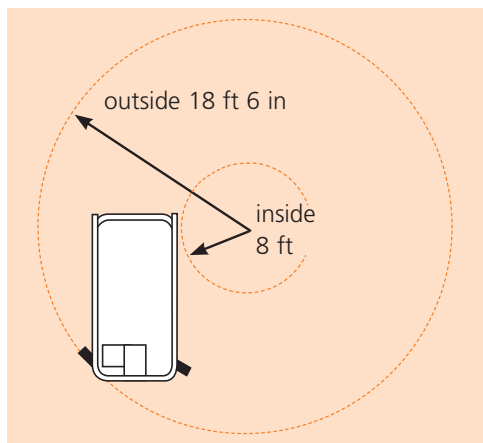

## STANDARD FEATURES

- 4-wheel drive
- 4 hydraulic stabilizers with automatic levelling
- Dual powered extension decks
- Proportional controls
- Foam filled tires
- Power line to platform
- Platform overload system
- Drive motion alarm
- Descent alarm
- Locking, oscillating axle
- Fold-down guardrails
- Manual lowering valve
- Flashing amber light (x2)
- Dual lanyard attachment points
- Hour meter & on-board diagnostics display
- 2 year parts & labor, 5 year structural warranty
- ANSI compliant

## OPTIONS

- Special paint colors
- Nylon spreader pads (set of 4)
- Environmental hydraulic oil
- Dual fuel
- Non-marking foam filled tires
- Cold weather package (block heater + battery warm up)
- Hydraulic 110V 2kW generator
- 12kW generator package
- Snorkel OnSite™ telematics

**snorkel** [www.snorkellifts.com](http://www.snorkellifts.com)

P.O. Box 1160  
St. Joseph, MO 64502-1160, USA  
Tel: 1 (785) 989-3000  
Toll-free: 1 (800) 255-0317  
Fax: 1 (785) 989-3070  
Email: sales.usa@snorkellifts.com